

COFFING[®]

HOISTS

OPERATING & MAINTENANCE INSTRUCTIONS WITH PARTS LIST

Publication Part No. WR-3-680-1

WR-3 - Large Frame Electric Wire Rope Hoist

For Capacities:

1 - 3 Ton

IMPORTANT – CAUTION

To safeguard against the possibility of personal injury or property damage, follow the recommendations and instructions of this manual. This manual contains important information for the correct installation, operation, and maintenance of this equipment. All persons involved in the installation, operation, and maintenance of this equipment should be thoroughly familiar with the contents of this manual. Keep this manual for reference and further use.

▲ WARNING

To prevent personal injury, do not use the equipment shown in this manual to lift, support, or otherwise transport people, or to suspend unattended loads over people.

TABLE OF CONTENTS

		PAGE
SECTION I	INTRODUCTION	
1-1	General Information	1
1-4	General Usage Information	1
1-9	Hoist Construction	1
1-13	Clutch Data	1
1-15	Basic Hoist Data	2
SECTION II	PREPARATION FOR USE	
2-1	Inspection Prior to Initial Use	2
2-4	Installation	2
2-6	Oil Level	2
2-8	Load Hook Direction (Phasing)	3
2-11	Testing	3
2-15	Trolley Mounting	3
SECTION III	OPERATION	
3-1	Safety Considerations	7
3-3	Operation	7
SECTION IV	MAINTENANCE, REPAIR AND LUBRICATION	
4-1	Limit Switch Adjustment	8
4-5	Motor Brake Adjustment	9
4-8	Replacement of Wire Rope	9
4-12	Inspections	12
4-14	Frequent Inspections	12
4-16	Periodic Inspections	12
4-18	Inspection of Hoist Not in Regular Use	13
4-20	Cleaning.....	13
4-22	Lubrication	14
SECTION V	TROUBLESHOOTING	
5-1	General	18
SECTION VI	WIRING	
6-1	Voltage Conversion	20
6-2	Wiring Diagrams	20
SECTION VII	ILLUSTRATED PARTS LISTS	
7-1	General	32
7-3	How to Use the Parts List	32
7-5	Warranty	33
Figure 7-1	Basic Hoist	34
Figure 7-2	Hoist Motor Parts	36
Figure 7-3A	Controller Area (Single Speed Hoist)	37
Figure 7-3B	Controller Area (Two Speed Hoist)	38
Figure 7-3C	Controller Area (Single Speed Hoist, Single Speed Trolley)	39
Figure 7-4	Hoist Transmission	40
Figure 7-5A	Drum Area (1 & 2 Ton) Standard Headroom Models	42
Figure 7-5B	Drum Area (3 Ton) Standard Headroom Models	43
Figure 7-5C	Drum Area (1 & 2 Ton) True Vertical Lift Models	44
Figure 7-5D	Drum Area (1 & 2 Ton) Low Headroom Models	46
Figure 7-6	Limit Switch Parts	48
Figure 7-6A	Long Lift Limit Switch	48
Figure 7-7A	Motor Brake Parts (2 HP)	49
Figure 7-7B	Motor Brake Parts (3 HP)	50
Figure 7-8A	Pushbutton (Single Speed Hoist)	51
Figure 7-8B	Pushbutton (Two Speed Hoist)	53
Figure 7-8C	Pushbutton (Single Speed Hoist, Single Speed Trolley)	55
Figure 7-8D	Pushbutton (Two Speed Hoist, Single Speed Trolley; or Single Speed Hoist, Two Speed Trolley)	57
Figure 7-8E	Pushbutton (Two Speed Hoist, Two Speed Trolley)	59
Figure 7-9A	Bottom Block (1 & 2 Ton) Standard Headroom Models	61
Figure 7-9B	Bottom Block (3 Ton) Standard Headroom Models	62
Figure 7-9C	Bottom Block (1 & 2 Ton) Low Headroom & True Vertical Lift	63
Figure 7-10A	Trolley General Assembly (Single Speed Hoist, Single Speed Trolley)	64
Figure 7-10B	Trolley General Assembly (Single Speed Hoist, Two Speed Trolley; Two Speed Hoist, Single Speed Trolley; Two Speed Hoist, Two Speed Trolley)	66
Figure 7-11	Plain Trolley — Two Wheel	68
Figure 7-12	Trolley Transmission	69
Figure 7-13	Trolley Motor Parts	70
Figure 7-14A	Trolley Control, Single Speed (Single Speed Trolley, Two Speed Hoist)	71
Figure 7-14B	Trolley Control, Two Speed (Two Speed Trolley with One or Two Speed Hoist)	72
Figure 7-16	Geared Trolley	73

SECTION I INTRODUCTION

1-1. GENERAL INFORMATION.

1-2. This manual provides necessary and proper information for persons engaged in the operation, maintenance, and installation of this Coffing WR-3 Series Hoist and Trolley. Any person operating or maintaining this hoist must be familiar with the information contained herein. Adherence to the precautions, procedures and maintenance practices described herein should ensure long and satisfactory use of your hoist with minimum danger to life, limb and property. Major overhaul efforts are not within the scope of this manual; such repairs should be made at an approved service center or by us. If any operating or maintenance information herein seems inadequate for your particular problem, please call or write our service engineers. We solicit your suggestions for improvements to this manual.

1-3. All persons concerned with the installation operation, inspection, and maintenance of this hoist are urged to read American National Standard ANSI B30.16. That standard contains important rules (some mandatory and some of an advisory nature) designed primarily to prevent or minimize injury and otherwise protect life, limb and property. You should especially be aware of the mandatory rules pertaining to inspection requirements and the advisability of maintaining written, dated, and signed inspection reports and records.

1-4. GENERAL USAGE INFORMATION.

1-5. This hoist is intended for general industrial use in the lifting and transporting of freely suspended material loads within its rated capacity. Prior to installation and operation, we caution the user to review his application for abnormal environmental or handling conditions and to observe the applicable recommendations as follows:

1-6. Adverse Environmental Conditions

Do not use the hoist in areas containing flammable vapors, liquids, gases or any combustible dusts or fibers. Refer to Article 500 of **The National Electric Code**. Do not use this hoist in highly corrosive, abrasive or wet environments. Do not use this hoist in applications involving extended exposure to ambient temperatures below -10°F or above 130°F.

1-7. Lifting of Hazardous Loads

This hoist is not recommended for use in lifting or transporting hazardous loads or materials which could cause wide-spread damage if dropped. The lifting of loads which could explode or create chemical or radioactive contamination if dropped, requires failsafe redundant supporting devices which are not incorporated into this hoist.

1-8. Lifting of Guided Loads

This hoist is not recommended for use in the lifting of guided loads, including dumbwaiters and nonriding elevators. Such applications require additional protective devices which are not incorporated into this hoist. Refer to your state and local regulations governing the requirements for elevator and dumbwaiter installations.

1-9. HOIST CONSTRUCTION.

1-10. This Coffing Hoist incorporates a steel drum and center frame with malleable and ductile iron castings in load bearing areas. For non-load bearing areas, a strong, lightweight, die case aluminum alloy is used. This combination results in a hoist that has high strength at a minimum weight.

1-11. A strain cable is built into the pushbutton cable and is securely anchored to the pushbutton station and the hoist housing. The pushbutton station may be used to pull the hoist when mounted on a free moving trolley. However, it is recommended that a hand geared or motorized trolley be used when the pulling effort required to move the hoist exceeds 100 pounds or when the application requires frequent horizontal movement of the hoist.

1-12. Automatic limit switches are built into the hoist to protect it against damage resulting from overtravel in either direction. When these switches are properly maintained and adjusted, the operator need not be overly concerned about damaging the hoist due to exceeding the functional travel limits of the hoist. The operator should bear in mind, however, that the limit switches are **safety devices**, and routine or constant use of them to stop hoist travel must be avoided.

1-13. CLUTCH DATA.

1-14. This hoist is equipped with a factory calibrated torque limiting device (load equalizer assembly, 36, Figure 7-4). The load equalizer clutch assembly will permit operation of hoist within its rated load capacity limits but will prevent lifting of excessive overloads. If the load to be lifted exceeds the lifting capability of the load equalizer clutch assembly, the hoist motor will continue to run while slipping the load equalizer assembly. This condition will cause overheating of the load equalizer assembly and should be avoided. If this condition occurs, release the "Up" button immediately and reduce the load to within the rated capacity of the hoist. The load equalizer assembly is not to be adjusted or interchanged with other models. To do so voids warranty and may create an unsafe condition.

1-15. BASIC HOIST DATA.

1-16. The operator should be aware of the capabilities and capacity of his hoist. He must refrain from overloading. Overloading not only can cause damage to the hoist, but presents serious threats to persons around the hoist. The following basic hoist data is related to general model numbers.

TABLE 1. BASIC HOIST DATA

Model Number	Rated Load (Lbs.)	Lift Speed At Rated Load (Ft. Per Min)	Motor HP
WR-2028	2000	28	2
WR-4014	4000	14	2
WR-4021	4000	21	3
WR-6010	6000	10	2
WR-6014	6000	14	3

SECTION II PREPARATION FOR USE

2-1. INSPECTION PRIOR TO INITIAL USE.

2-2. Any new or repaired hoist, as well as the working area, shall be carefully inspected prior to initial installation and use. The inspection shall be made by or under the direction of a person familiar with hoist operations and industrial safety standards.

2-3. The following inspection criteria are recommended prior to initial installation and use. Additional inspection items should be added to satisfy local usage and safety requirements. All inspections of any kind should be logged or recorded, dated, signed, and filed for reference.

a. Ensure that the facility power supply is adequate to furnish voltage while the hoist is lifting load within 10 percent of that specified for the hoist. Also, that the facility power is properly fused to protect the hoist from power surges.

b. Ensure that no live part of the electrical system, either facility or hoist, will be exposed to accidental contact under normal operating conditions.

c. Ensure that the hoist is effectively grounded and that the circuit supplying power to the hoist is equipped with a suitable overcurrent device and disconnecting means. If in doubt, reference National Electrical Code ANSI C1.

d. Ensure that the supporting structures are strong enough to carry the intended loads. The supporting structure shall have a safe load rating at least equal to that of the hoist. The supporting structure must be rigid and not subject to weakening due to repeated stresses from the hoist.

e. Ensure that there is adequate working space to permit hoist operation in the hanging position only. Normal operation should not require pulling or tugging around corners or obstructions. Also, there must be adequate space to permit the operator and other persons to stand clear of the load and adjacent structures.

f. Watch out for makeshift or compromising practices either during installation or subsequent operation of the hoist. Sometimes the "temporary" fix remains until an accident occurs.

g. Perform both the daily and the periodic inspections specified herein on a repaired hoist prior to initial use. Perform the daily inspections specified herein on a new hoist prior to initial use.

2-4. INSTALLATION.

2-5. Secure the hoist to a suitable supporting structure through mounting holes provided in the suspension (8, Figure 7-5A, or 8, Figure 7-5B). **IMPORTANT:** Use Duff-Norton supplied load pins to assure proper hoist mounting. If substitutions are necessary, use $\frac{3}{4}$ inch diameter S.A.E. Grade 5 bolts. On trolley mounted hoists, the trolley should be properly mounted to allow for clearance between trolley wheels and beam flange to avoid binding. The beam should be free of any obstructions, dirt, or grease, providing a free and level plane of movement. See Figures 2-1, 2-2, and 2-3.

NOTE

All trolley mounted hoists must be mounted with the drum parallel to the beam. This will keep the load point under the centerline of the beam and will minimize off center loading problems.

2-6. OIL LEVEL.

2-7. This hoist has an oil filled transmission. For shipping purposes, a non-vented fill plug was installed at the factory. A vented plug (39, Figure 7-4) is located in an envelope attached to the hoist. The vented plug must be installed in place of the non-vented shipping plug before the hoist can be operated. In addition, the transmission oil level should be checked prior to placing hoist in operation. To check oil level, remove level plug (42). Observe if oil is even with or above bottom of tapped hole. If not, add oil as specified on lubrication schedule. Figure 4-7.

CAUTION

REPLACE OIL ONLY WITH THAT SPECIFIED IN THIS MANUAL. This lubricant has additives for optimum resistance to chemical change due to heat, and for smooth clutching action of the load brake. The hoist warranty is void if unapproved oil is used.

2-8. LOAD HOOK DIRECTION (PHASING).

2-9. Connect hoist to electrical power source as follows:

NOTE

This hoist must be connected to a 3 phase power supply. The hoists are dual voltage (230/460V) and wired for 460V unless otherwise specified.

If hoists are to be connected to 230V power supply, proceed with steps a., b., and c. If hoists are to be connected to 460V supply, proceed with step c.

- a. Remove the electrical cover (2. Figure 7-1.)
- b. See Section VI, Wiring, for voltage conversion instructions.
- c. After ascertaining that voltages of the power source and the hoist are the same, make only temporary connections at the power source for THREE PHASE models. Push the "UP" button and observe the direction of the load block. If the hook raises, the phasing is correct and permanent connections may be made at the power source. If the hook lowers, release the button immediately, since the limit switches will not operate to prevent hoist over-travel. To correct the load hook direction (phasing), reverse any two wires (except the green ground wire) at the power source only. **DO NOT CHANGE CONNECTIONS AT ANY OTHER LOCATION.**

2-10. After electrical connections are completed, secure all protective covers over exposed wiring. Test the hoist operation as specified below prior to release for use.

2-11. TESTING.

2-12. Before placing hoist in operation, check for proper limit switch operation as follows:

- a. Carefully raise the unloaded load block to upper limit and observe if it stops automatically at the maximum level. (See note in paragraph 2-13.) Do not allow load block to run into hoist drum — or possible damage may result to hoist. If load block does not stop at desired level, see paragraph 4-1 for limit switch adjustment.
- b. Carefully lower the unloaded load block to lower limit and observe if it stops automatically at the maximum level. (See note in paragraph 2-13.) This should occur when 1½ wraps of wire rope are left on the drum. If load block does not stop at desired level, see paragraph 4-1 for limit switch adjustment.

2-13. After limit switch testing is complete **DISCONNECT HOIST FROM POWER SUPPLY** and replace brake cover and control cover. Secure all protective covers over exposed wiring. Re-establish power and continue testing hoist as specified below prior to release for use.

NOTE

The upper and lower limit switches are factory set to provide the maximum allowable hook travel and should not be adjusted to increase this travel. They can, however, be adjusted to automatically stop the hoist at points within these maximum limits (see paragraph 4-1 for adjustment procedure).

2-14. Wire rope life can be extended by a short breaking-in period before the hoist is put into service. During this breaking-in period, a small amount of twist may show up in the rope. This twist should be removed as described below. This break-in can be done at the time of hoist testing:

- a. Attach a light load to the hook and run the hoist through its full stroke for a few lifting and lowering cycles. Check for hook drift. The hook should not drift more than one inch.
- b. If brake operation is normal with a light load, repeat the above procedure with approximately one-half rated load, again running the hoist through its full lift stroke for a few cycles. Check again for hook drift.
- c. If brake operation is normal with one-half rated load, attach rated load to the hook and continue the break-in procedure. The hoist shall operate smoothly and the brake should prevent hook drift in excess of one inch at rated load. See paragraph 4-5 if motor brake adjustment is required.
- d. Set the load on the floor. Disconnect the dead end of the wire rope by removing the dead end anchor screw (18, Figure 7-5A or 7-5B). Allow the dead end to rotate, in order to remove all twist from the rope. Reconnect the dead end and be sure to replace and tighten the anchor screw.

2-15. TROLLEY MOUNTING.

2-16. The Coffing Trolleys can be mounted on standard "T" beams. The trolleys will mount on 6" through 18" depth "T" beams. This is accomplished by properly locating the spacer washers as shown in Tables 2-1, 2-2, and 2-3. Washers should be equally spaced on each side of the hoist suspension so that a clearance of about $\frac{3}{32}$ " (.094") is obtained between the beam and each wheel flange. Tables 2-1, 2-2, and 2-3 provide an approximate guide to washer placement. Be sure to use the proper Table, based on hoist capacity (tons) and trolley type.

NOTE

Beam manufacturing tolerances allow wide variations from handbook flange widths. The particular beam on which your hoist is to be installed should be measured and the trolley spacer washers adjusted as required to achieve a $\frac{3}{32}$ " clearance. Two thicknesses of washers are provided. This allows fine adjusting to achieve the required spacing.

Trolleys can be mounted on beam radii as small as 4 feet. Slightly increased spacing may be required when the trolley is mounted on curved beams to maintain freedom of movement.

2-17. The load pin nuts for the trolleys require a tightening torque of 100 ft. lbs. Refer to Figures 2-1, 2-2, and 2-3 for nut identification.

CAUTION

Make sure all supporting structures are strong enough to hold the full rated load of the trolley with a generous factor of safety.

**WR-3 HOISTS ON COFFING TROLLEYS
(1-TON & 2-TON HOISTS, FOUR-WHEEL TROLLEY)**

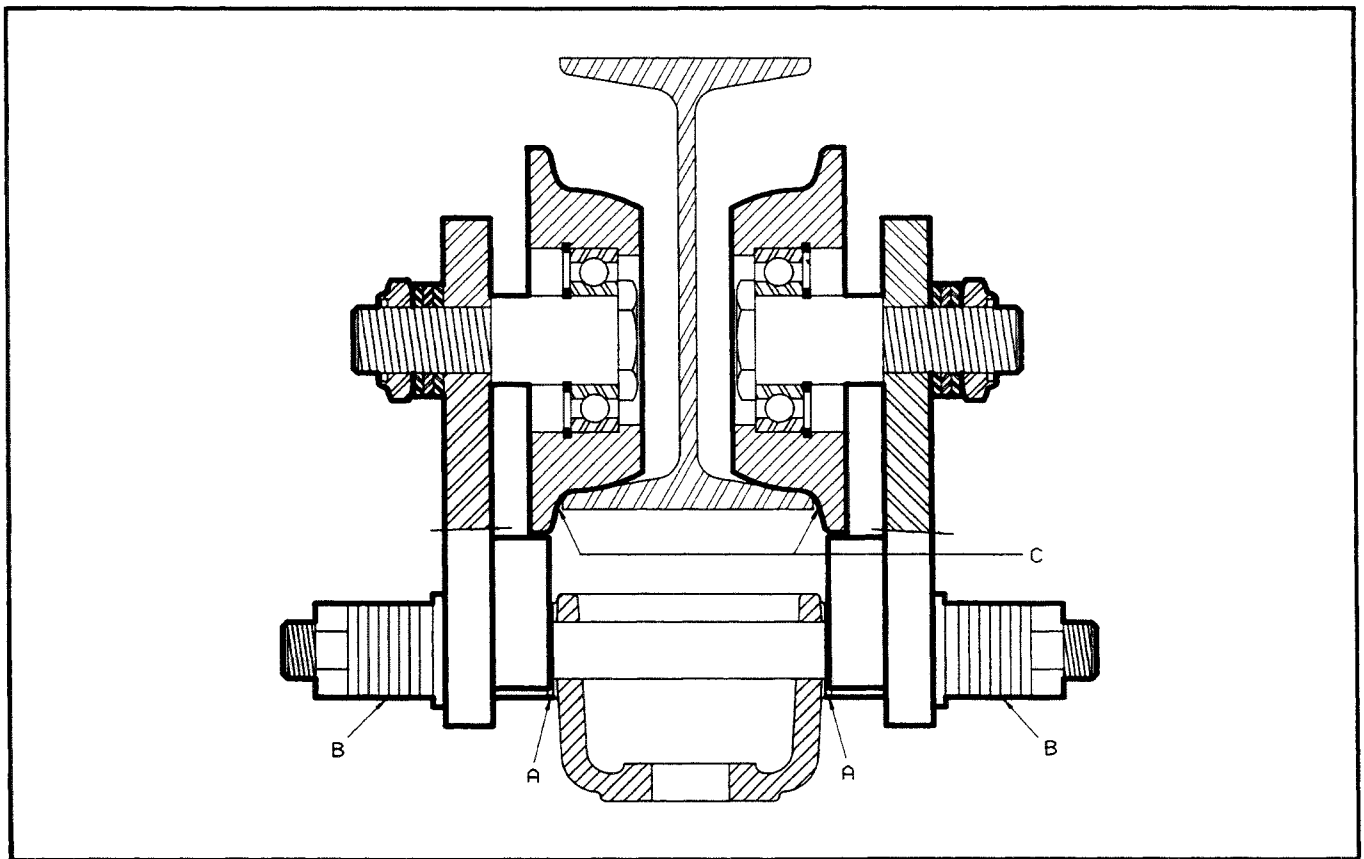

FIGURE 2-1

TABLE 2-1

		"I" Beam Size					
		6"	8"	10"	12"	15"	18"
Washers Between Hoist & Trolley	Thick	0	0	3	6	5	7
	Thin	0	5	4	1	6	6
Washers Outside Trolley	Thick	7	7	4	1	2	0
	Thin	9	4	5	8	3	3

3-TON HOIST, FOUR-WHEEL TROLLEY

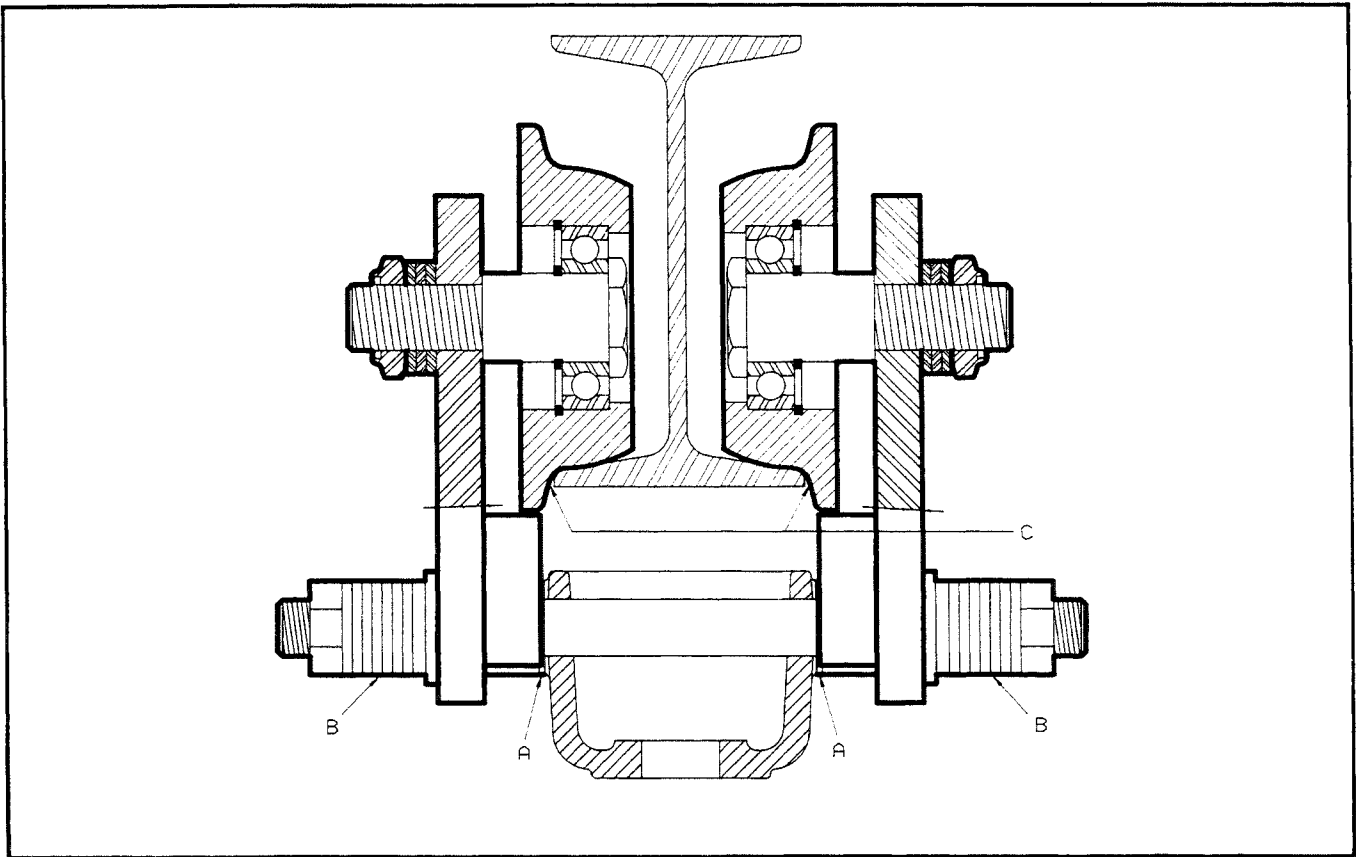

FIGURE 2-2

TABLE 2-2

		"I" Beam Size					
		6"	8"	10"	12"	15"	18"
Washers Between Hoist & Trolley	Thick	0	0	3	6	5	7
	Thin	0	5	4	1	6	6
Washers Outside Trolley	Thick	7	7	4	1	2	0
	Thin	9	4	5	8	3	3

1-TON, 2-TON OR 3-TON HOIST, TWO-WHEEL TROLLEY

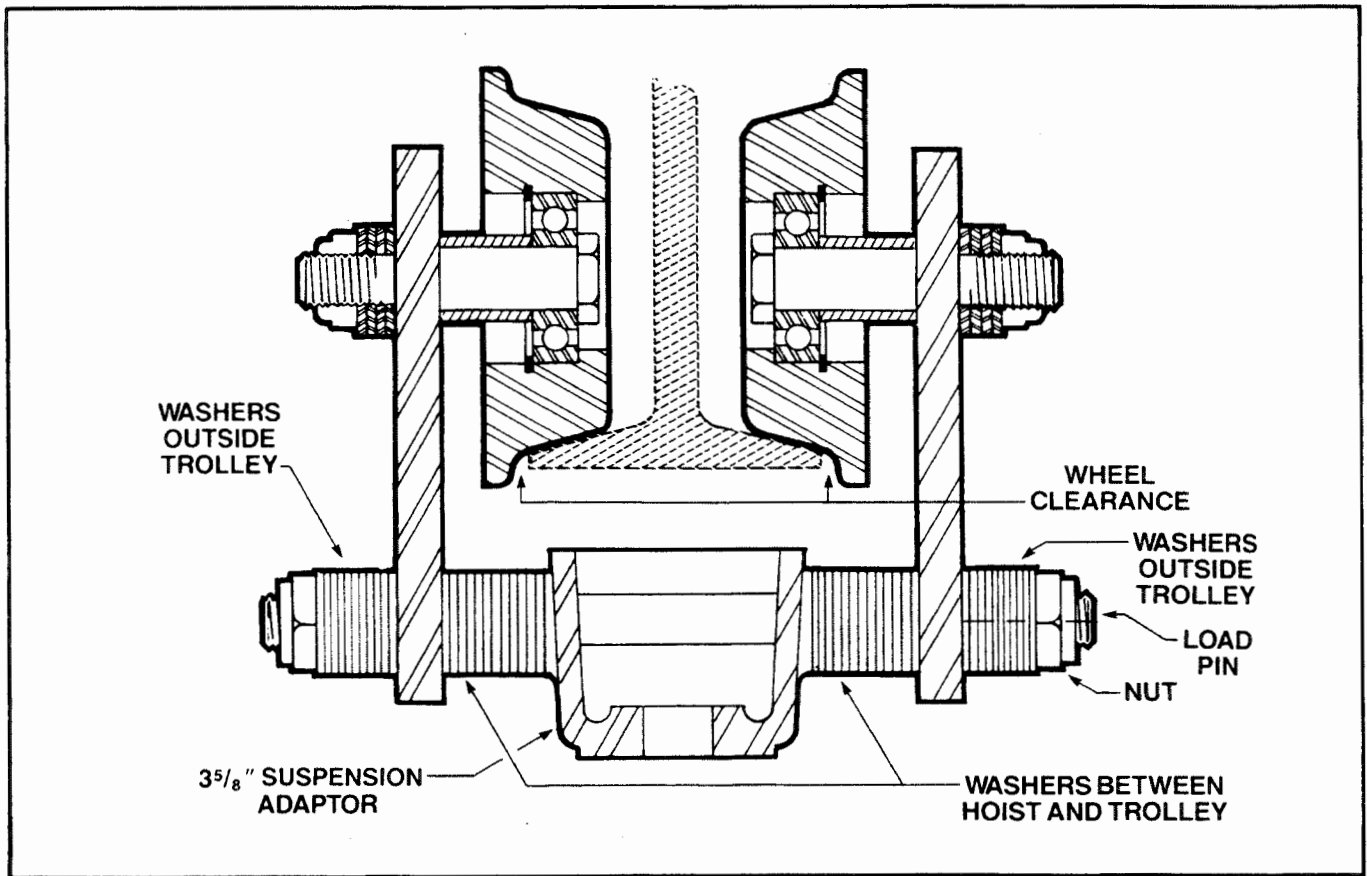

FIGURE 2-3

TABLE 2-3

		"I" Beam Size					
		6"	8"	10"	12"	15"	18"
Washers Between Hoist & Trolley	Thick	4	7	10	8	11	11
	Thin	4	3	2	8	6	9
Washers Outside Trolley	Thick	7	4	1	3	0	0
	Thin	6	7	8	2	4	1

SECTION III OPERATION

3-1. SAFETY CONSIDERATIONS.

3-2. This hoist is designed for proper operation within the limits of its rated capacity. The hoist has features designed to minimize the potential for injury due to the failure of the hoist itself. This hoist is intended for use in the vertical lifting of freely suspended material loads. Applications involving the lifting of guided loads, such as dumbwaiters and non-riding elevators require additional safety devices. Before using this hoist in such applications, consult the local, state and federal codes.

Here are some additional pointers which should be followed in order to ensure proper operation.

a. Do not overload the hoist. This hoist is equipped with a torque limiting device (load equalizer assembly, 36, Figure 7-4). This device will prevent lifting of damaging overloads but this feature is not intended to invite, condone or grant permission to lift loads greater than the rated capacity of the hoist, see Table 1.

b. Do not make side pulls with the hoist. Trolley mounted hoists should always be positioned directly over the load before lifting.

c. Operate the hoist only in a hanging position with adequate support. Make sure that the load does not contact any obstructions.

d. Before raising a load, always check to see that it is held securely in the hook or sling chains, etc. Raise the load only until the wire rope is taut and then double check the rigging before continuing to raise the load. Never use the hoist wire rope in sling fashion around the load.

e. Make sure that the slings and other rigging have sufficient capacity to support the load, and are in good condition.

f. **DO NOT STAND OR WALK BENEATH A LOAD.** Do not move the load in such a manner as to endanger personnel.

g. Never leave a suspended load unattended.

h. Do not lower the load into areas where visibility is obscured unless someone else is guiding the operation.

i. Use common sense at all times when operating a hoist.

j. **DO NOT USE THE HOIST TO LIFT, TRANSPORT, OR OTHERWISE SUPPORT PEOPLE.**

NOTE

The information herein is directed to the proper use, care and maintenance of the WR-3 Hoist and does not comprise a handbook on the broad subject of rigging. Rigging can be defined as the process of lifting and moving heavy loads using hoists and other mechanical equipment. Skill acquired through specialized experience and study is essential to safe rigging operations. For rigging information, we recommend consulting a standard textbook on the subject.

3-3. OPERATION.

3-4. The hoist should be operated by qualified personnel only. Be sure to perform the daily inspections specified herein prior to first use each day. Pay particular attention to the limit switch operation, the brakes, and rope travel onto the drum. Avoid excessive inching and quick reversals as these can cause overheating, accelerated brake wear, and unnecessary stresses. Do not routinely move the hook so as to actuate the limit switches, as these are safety devices only. Avoid swinging the load or hook if the hoist is mounted on a trolley. Do not operate the hoist if it is functioning improperly, has been inadvertently overloaded, or is in obvious need of repair. Always affix a warning or "Out-of-Order" tag to the control station and disconnect hoist from power supply until the proper inspection-repair has been made.

SECTION IV MAINTENANCE, REPAIR AND LUBRICATION

4-1. LIMIT SWITCH ADJUSTMENT.

4-2. Limit switches are provided to protect the hoist against damage resulting from over-travel or to allow setting the hoist travel within a prescribed travel range. For easy identification and association with the proper travel the upper and lower limit switch adjusting nuts (2 and 3, Figure 4-1) are colored red and green respectively. The increment of adjustment is as follows: One complete revolution (ten slots) of either nut is equivalent to approximately 7 $\frac{3}{4}$ " of hook travel on the 1 & 2 Ton hoist or approximately 3 $\frac{7}{8}$ " of hook travel on the 3-Ton hoist. One slot is equivalent to approximately $\frac{3}{4}$ " of hook travel on the 1 & 2-Ton hoist or approximately $\frac{3}{8}$ " on the 3-Ton. Movement of the limit switch nuts toward or away from each other increases or decreases the hook travel respectively. Care should be exercised when adjusting either limit of travel.

CAUTION

If the wires running to the limit switches are disconnected for any purpose, refer to applicable wiring diagram (Section VI of this manual) for proper location of wires.

4-3. Adjust Upper Limit (Red Nut) as follows:

a. Carefully raise the load block to a point where the top of it is three inches or more from the hoist drum (or to the limit desired in the particular application, allowing the minimum of three inches).

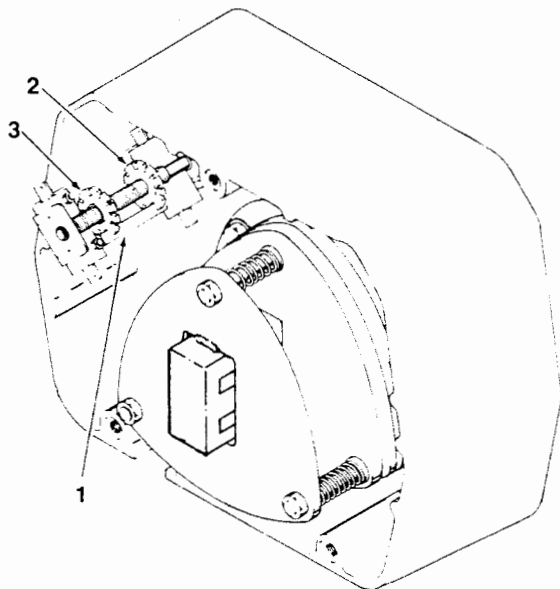

FIGURE 4-1. LIMIT SWITCH ADJUSTMENT

b. DISCONNECT HOIST FROM POWER SUPPLY and remove the brake cover (1, Figure 7-1).

c. With a screwdriver, pry the spring guide plate (1, Figure 4-1) out of the slots in the colored limit switch nuts (2 and 3).

d. Turn the slotted red nut (2) towards its limit switch until the limit switch "clicks";* then turn two SLOTS further. Release the spring guide plate and be sure it slips back into the slots in the colored limit switch nuts. Do not disturb the other slotted nut if it has been set previously.

e. Replace brake cover and connect hoist to power supply.

f. Verify the limit switch setting by first lowering the load block and then carefully inching it back toward the hoist until the switch is actuated.

4-4. Adjust Lower Limit (Green Nut) as follows:

a. Carefully lower the load block to a point where there is a minimum of 1 $\frac{1}{2}$ wraps of wire rope left on the drum (or to the limit desired in the particular application, allowing the minimum 1 $\frac{1}{2}$ wraps).

b. DISCONNECT HOIST FROM POWER SUPPLY and remove the brake cover (1, Figure 7-1).

c. With a screwdriver, pry the spring guide plate (1, Figure 4-1) out of the slots in the colored limit switch nuts (2 and 3).

d. Turn the slotted green nut (3) towards its limit switch until the limit switch "clicks";* then turn two SLOTS further. Release the spring guide plate and be sure it slips back into the slots in the colored limit switch nuts. Do not disturb the other slotted nut if it has been set previously.

e. Replace brake cover and connect hoist to power supply.

f. Verify the limit switch setting by first raising the load block and then carefully inching it back toward the lower setting point until the switch is actuated.

*If difficulty is encountered in detecting the "click" of the limit switch, a continuity testing device should be used to determine the point at which the switch breaks the control circuit.

4-5. MOTOR BRAKE ADJUSTMENT.

4-6. The criteria for the correct brake adjustment is its performance. Properly adjusted, the brake will release promptly when energized; is capable of both smoothly stopping and securely holding the rated capacity of the hoist. If the hoist develops either undesirable over-travel after the push-button is released (this condition is most noticeable in the lowering direction) or hesitates to lift the load promptly when the push-button is depressed (this condition is most noticeable in the hoisting direction) the brake should be adjusted. If adjustment of the motor brake does not correct the hesitation, the load equalizer assembly may require replacement. See Section V.

4-7. To Adjust Brake, proceed as follows:

- a. Remove any load and DISCONNECT THE HOIST FROM POWER SUPPLY.
- b. Remove brake cover (1, Figure 7-1).
- c. Check the gap between brake armature (A, Figure 4-2) and field (B). The correct gap is 0.015 inch. Adjustment should not be necessary until gap reaches 0.050 inch unless brake chatter is experienced. See Section V.
- d. Adjust gap by adjusting the three lock nuts (F) and checking with a feeler gauge to be sure gap is the same on both ends of the solenoid.

CAUTION

Be sure the bottom of the armature plate does not bear against the brake adapter (H). As wear occurs and adjustments are made the built in clearance will be reduced. When this clearance is gone REPLACE BRAKE DISCS.

e. Adjustment is now complete and the brake properly set. Replace the brake cover, reconnect the power supply, and check brake operation per paragraph 2-14. If brake operates improperly, see troubleshooting, Section V.

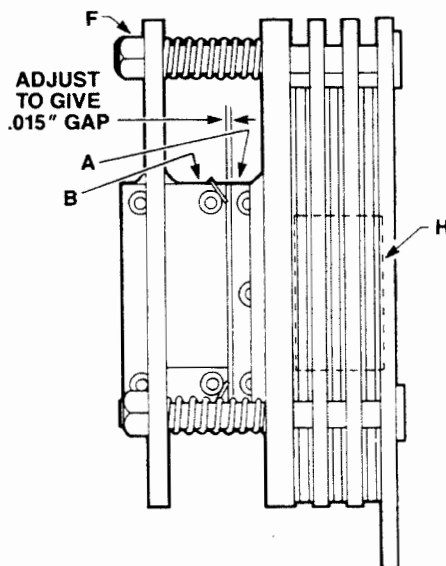

FIGURE 4-2. MOTOR BRAKE ADJUSTMENT

4-8. REPLACEMENT OF WIRE ROPE.

4.9 1 & 2-TON HOISTS, STANDARD HEADROOM MODELS: Refer to Figure 4-3A for parts identification and proper cable reeving.

- a. Push "Down" button and run old rope out until stopped by lower limit switch.
- b. Disassemble the load block by removing the two bolts (11, Figure 7-9A) and the large nut (4) on the grease fitting side. Clean and inspect the block, hook, sheave, bearings, and pin for wear, damage, etc. Replace parts as necessary. Do not reassemble the load block at this point.
- c. DISCONNECT HOIST FROM POWER SUPPLY and remove brake cover (1, Figure 7-1).
- d. With a screwdriver, push the spring guide plate (1, Figure 4-1) out of the slots in the plastic limit switch nuts. Turn the green slotted nut (3) back to about the center of the screw thread. DO NOT DISCONNECT THE WIRES FROM THE LIMIT SWITCHES.
- e. With the brake cover off, reconnect the hoist to power supply. Be sure the green ground wire is properly grounded.
- f. Carefully jog the "Down" button until all old rope is run off and the drum socket opening is accessible.
- g. Disconnect old rope dead end by removing the dead end anchor screw (18, Figure 7-5A). This requires a $\frac{5}{16}$ " allen wrench. Lift the eye fitting of the old rope off the anchor pin.
- h. Slide the sleeve fitting of the rope out of the drum socket. Remove and discard the old rope.
- i. Place paper on floor to protect the new wire rope from dirt and grit. Stretch the new wire rope out on the paper with the sleeve fitting end toward the hoist. Relieve any twist in the new rope.
- j. Insert the new rope's sleeve fitting into the drum socket, making sure the fitting is properly seated.

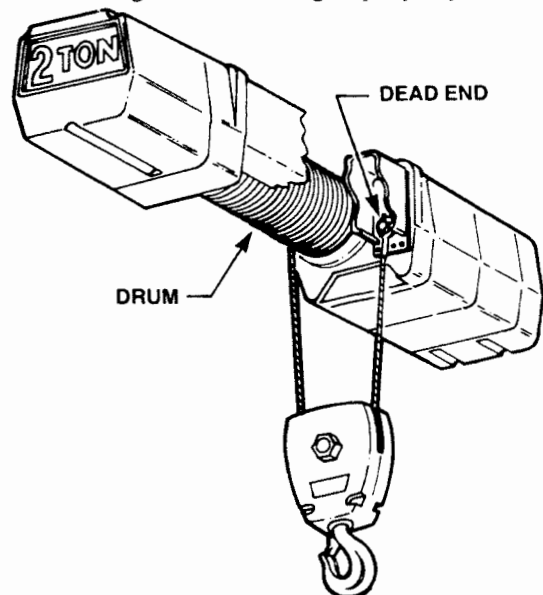

FIGURE 4-3A. WIRE ROPE REEVING
(1 & 2 TON, STANDARD HEADROOM MODELS)

k. Push the "Up" button until about half of the new rope is wound onto the drum. Apply slight tension to the rope with a gloved hand to wind rope evenly on the drum.

l. Attach the dead end by placing the new rope's eye fitting over the anchor pin. Be sure to replace and tighten the dead end anchor screw, since it serves to prevent the dead end fitting from working itself off the anchor pin.

m. Reassemble the load block onto the new wire rope. See Figure 7-9A for aid in reassembly. Refer to Figure 4-3A to make sure that the rope is reeved correctly.

n. Adjust the limit switches per paragraph 4-1.

o. Test the hoist and break-in the wire rope per paragraph 2-14.

4-10. 1 & 2 TON HOISTS, TRUE VERTICAL & LOW HEADROOM MODELS:

Refer to Figure 4-3B or 4-3C for parts identification and proper rope reeving.

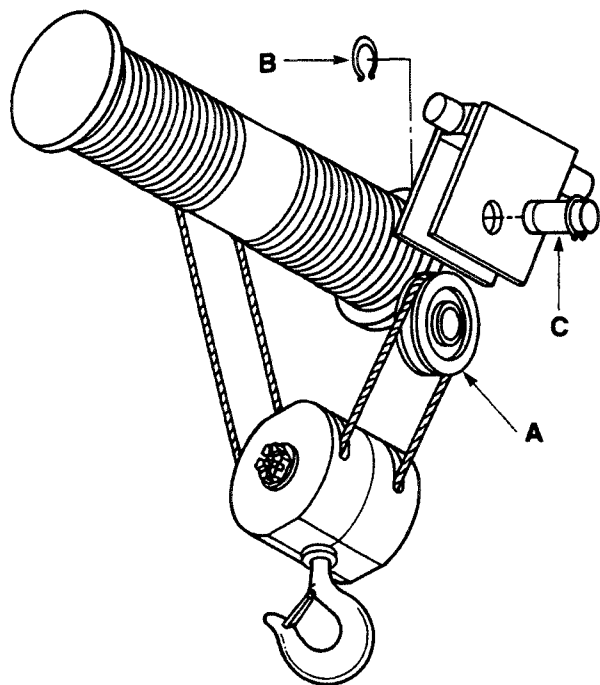

**FIGURE 4-3B. WIRE ROPE REEVING
(1 & 2 TON, TRUE VERTICAL LIFT MODELS)**

1. Push "DOWN" button and run old rope out until stopped by lower limit switch.
2. Disassemble the load block by removing the spring pins (53, Figure 7-9C) and the slotted nuts (51, Figure 7-9C). The block covers (52, Figure 7-9C) will still be captured by the rope. Clean and inspect the hook, sheaves, bearings and yoke for wear, damage, etc. Replace parts as necessary. Do not reassemble the load block yet.
3. DISCONNECT POWER from the hoist and remove the short end cover.
4. With a screwdriver, push the spring guide plate (1, Figure 4-1) out of the slots in the plastic limit switch nuts. Turn the

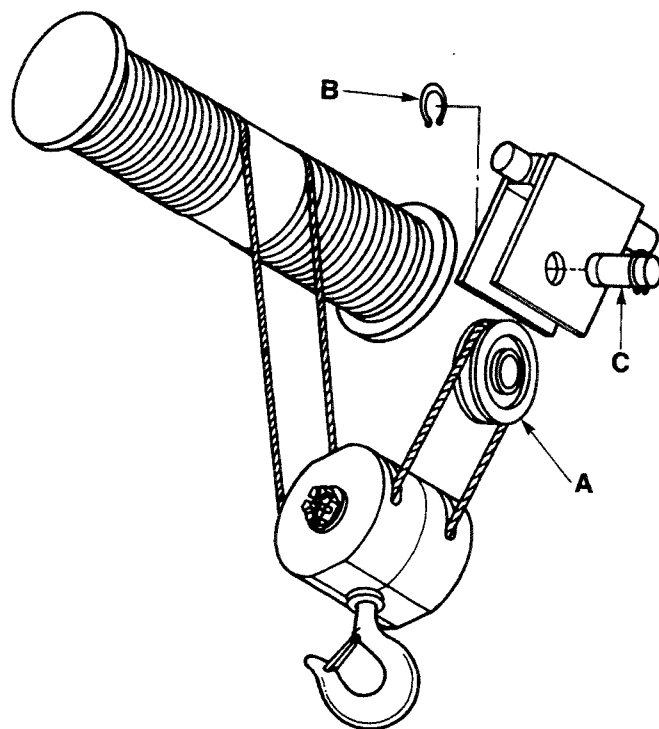

**FIGURE 4-3C. WIRE ROPE REEVING
(1 & 2 TON, LOW HEADROOM MODELS)**

green slotted nut (3) back to about the center of the threaded screw. DO NOT DISCONNECT THE WIRES FROM THE LIMIT SWITCHES.

5. With the end cover off, connect hoist to power supply. Be sure the green wire is grounded.

6. Carefully jog the "DOWN" button until all the old rope is run off and the drum socket openings are accessible.

7. DISCONNECT POWER from the hoist.

8. Remove the equalizer sheave. (A) Figure 4-3 by removing one retaining ring (B) and the sheave pin (C). Clean and inspect these parts.

9. Slide the sleeve fittings out of the drum sockets, and out of the block covers. Remove and discard the old rope.

10. Place paper on the floor to protect the new rope from dirt and grit. Stretch the new rope out in one length and relieve any twist. Then double the rope by bringing the two sleeve fittings together.

11. Pass each sleeve fitting through the rope openings in the block covers only. The block should remain disassembled at this point.

12. Insert each sleeve fitting into the drum sockets, making sure the fittings are properly seated.

13. Push the "UP" button until a few wraps of rope are wound onto the drum. Apply slight tension to the ropes with gloved hands to wind the rope evenly on the drum..

14. Place the looped end over the equalizer sheave and return the sheave to its frame. Reinstall the sheave pin and retaining ring.

15. At this point, only the block covers will be hanging from the two loops of rope.

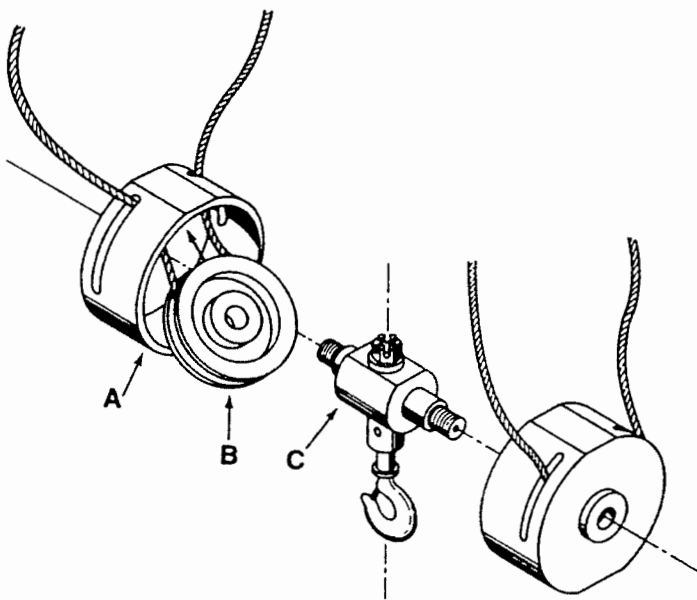

**FIGURE 4-4. ASSEMBLY OF LOAD BLOCK—
TWO PART DOUBLE REEVED**

16. Refer to Figure 4-4 for assembly of load block. Pull a loop of rope to the inside of the block cover (A), and place a sheave (B) in this loop. Angle the top of the sheave into the cover, while keeping the rope seated in the sheave groove. The sheave will now drop to the inside wall of the cover. Place the sheave and cover, as one unit, over the yoke (C), and hand-tighten the slotted nut. Repeat for the other side. Tighten both slotted nuts and install the spring pins. Refer to Figure 4-3B or 4-3C to make sure that the rope is reeved correctly.

17. Adjust the limit switches per paragraph 4-1.

18. Lubricate the wire rope per paragraph 4-23a. Test the hoist and break-in the wire rope per paragraph 2-14.

4-11. 3-TON HOISTS: Refer to Figure 4-3D for parts identification and proper cable reeving.

a. Push "Down" button and run old rope out until stopped by lower limit switch.

b. Disassemble the load block by removing the two bolts (7, Figure 7-9B) and the large nut (9). Clean and inspect the block, hook, sheaves, bearing and pin for wear, damage, etc. Replace parts as necessary. Do not reassemble the load block at this point.

c. DISCONNECT HOIST FROM POWER SUPPLY and remove brake cover (1, Figure 7-1).

d. With a screwdriver, push the spring guide plate (1, Figure 4-1) out of the slots in the plastic limit switch nuts. Turn the green slotted nut (3) back to about the center of the screw thread. **DO NOT DISCONNECT THE WIRES FROM THE LIMIT SWITCHES.**

e. With the brake cover off, reconnect the hoist to power supply. Be sure the green ground wire is properly grounded.

f. Carefully jog the "Down" button until all old rope is run off and the drum socket opening is accessible.

g. Remove the center-section covers (22 and 23, Figure 7-1). Remove the drum/idler guard (6, Figure 7-5B). Disconnect old rope dead end by removing the dead end anchor screw (18, Figure 7-5B). This requires a $\frac{5}{16}$ " allen wrench. Lift the eye fitting of the old rope off the anchor pin.

h. Slide the sleeve fitting of the rope out of the drum socket. Remove and discard the old rope.

i. Place paper on floor to protect the new wire rope from dirt and grit. Stretch the new wire rope out on the paper with the sleeve fitting end toward the hoist. Relieve any twist in the new rope.

j. Insert the new rope's sleeve fitting into the drum socket, making sure the fitting is properly seated.

k. Push the "Up" button until about half of the new rope is wound onto the drum. Apply slight tension to the rope with a gloved hand to wind rope evenly on the drum.

l. Pass the eye fitting of the new rope over the idler sheave and attach the dead end by placing the eye fitting over the anchor pin. This should form two loops of rope hanging from the hoist. Be sure to replace and tighten the dead end anchor screw, since it serves to prevent the dead end fitting from working itself off the anchor pin.

m. Reassemble the load block onto the new wire rope. See Figure 7-9B for aid in reassembly. Refer to Figure 4-3D to make sure that the rope is reeved correctly. Replace the drum/idler guard, making sure that the rope is properly seated in the idler sheave, and that the idler sheave rotates freely. Replace the center-section covers.

n. Adjust the limit switches per paragraph 4-1.

o. Test the hoist and break-in the wire rope per paragraph 2-14. Lubricate the wire rope per paragraph 4-23a.

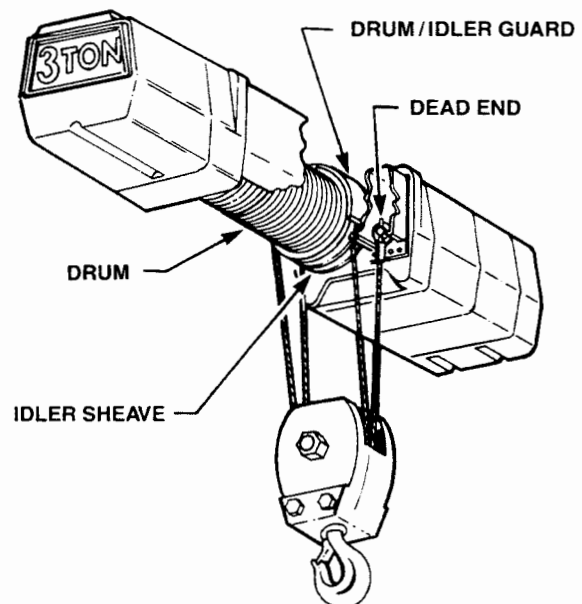

**FIGURE 4-3D. WIRE ROPE REEVING
(3-TON, STANDARD HEADROOM MODELS)**

CAUTION

Do not repair, shorten or substitute other wire rope. Use correct wire rope assembly specified in this manual.

4-12. INSPECTIONS.

4-13. A planned inspection routine should be established for this hoist based upon frequency of use, severity of use, and environmental conditions. (Reference American National Standard ANSI B30.16.) Some inspections should be made frequently (daily to monthly) and others periodically (monthly to yearly). It is strongly recommended that an Inspection and Maintenance Check List and an Inspector's Report similar to those shown in Figures 4-5 and 4-6 be used and filed for reference. All inspections should be made by, or under the direction of, a designated inspector. Special inspections should be made following any significant repairs or any operating occurrence leading one to suspect that the hoist's capabilities may have been impaired.

4-14. FREQUENT INSPECTIONS.

4-15. Perform the following inspections daily prior to initial use of the hoist.

CAUTION

Any unsafe condition disclosed by the inspection shall be corrected before operation of the hoist is resumed. Adjustments and repairs shall be done only by designated personnel.

- a. Check the operating controls for proper operation.
- b. Check the limit switches for proper operation.
- c. Check the brakes for proper operation.
- d. Inspect the hook for deformations, chemical damage, or cracks. Hooks damaged from chemicals, deformation or cracks or having throat openings greater than that listed in Figure 4-4 must be replaced.

NOTE

Any hook that is twisted more than 10 degrees from the plane of the unbent hook or has throat openings in excess of that listed in Figure 4-4 indicates abuse or overloading of the hoist. Other load bearing components should be inspected accordingly.

- e. Check that the hook swivels freely.
- f. Check hook latch to see that latch performs function of closing off the hook throat in a secure manner when load is attached.
- g. Check wire rope for wear, twist, distortion or improper dead-ending.

4-16. PERIODIC INSPECTIONS.

4-17. It is recommended that the following inspections be performed at one to 12 month intervals. The exact period of inspection will depend on frequency and type of usage. Determination of this period will be based on the user's experience. It is recommended that the user begin with a monthly inspection and extend the periods to quarterly, semi-annually or annually based on his monthly experience.

CAUTION

Any unsafe condition disclosed by the inspection shall be corrected before operation of the hoist is resumed. Adjustments and repairs shall be done only by designated personnel.

- a. Perform all the frequent inspections listed in paragraph 4-14.
- b. Check nuts, bolts, rivets, and other hardware for looseness, stripped or damaged threads, and corrosion.
- c. Check sheave and drum for distortion, cracks, and excessive wear.
- d. Check housings and load block for cracks (resulting from collision, dropping, etc.) and abnormal openings between housing sections (resulting from overloading).
- e. Check for worn, corroded, cracked or distorted parts such as pins, bearings, bushings, shafts (including splines), couplings and gears.
- f. Check disc brake for glazing, contamination or excessive wear.
- g. Check load brake function. See Figure 4-8.
- h. Make a thorough inspection of the wire rope at least once each month and keep a written, dated and signed report of rope condition on file. Any deterioration, resulting in appreciable loss of original strength, such as described below, shall be carefully noted and determination made as to whether further use of the rope would constitute a safety hazard.
 - (1) Reduction of rope diameter below nominal due to loss of core support, internal or external corrosion or wear of outside wires.
 - (2) A number of broken outside wires and the degree of distribution or concentration of such broken wires.
 - (3) Worn outside wires.
 - (4) Sections of rope which are normally hidden during inspection or maintenance procedures, such as parts passing over sheaves, should be given close inspection as these are points most subject to deterioration.
 - (5) Corroded or broken wires at end connections.
 - (6) Corroded, cracked, bent, worn or improperly applied end connections.
 - (7) Kinking, crushing, cutting or unstranding.

No precise rules can be given for determination of exact time for replacement of wire rope, since many variable factors are involved. Safety in this respect depends largely upon the use of good judgment by an appointed or designated person in evaluating remaining strength in the used rope after allowance for deterioration disclosed by inspection. Safety of rope operation depends upon this remaining strength. Conditions such as the following should be sufficient reason for questioning rope safety and consideration of replacement.

- (1) Twelve randomly distributed broken wires in one rope lay, or four broken wires in one strand in one rope lay.
- (2) Wear of one-third of the original diameter of outside individual wires.
- (3) Kinking, crushing, birdcaging or any other damage resulting in distortion of the rope structure.
- (4) Evidence of any heat damage from any cause.
- (5) Reductions from nominal $\frac{5}{16}$ inch diameter to $\frac{1}{4}$ inch.

CAUTION

Use only wire rope supplied by our company since replacement rope must be the same size, grade and construction as the original rope.

A rope which has been idle for a period of a month or more due to shutdown or storage of the hoist, shall be given a thorough inspection before it is placed in service.

- i. Check wire rope end fastenings. When two wires are broken adjacent at the end fastenings, the rope should be replaced.

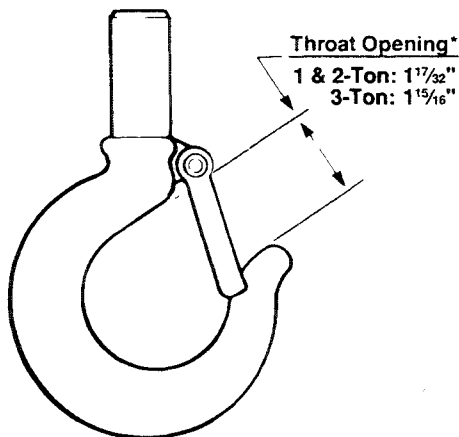

*Dimension of throat opening with internal latch.

NOTE: If hook is measured without hook latch, add $\frac{1}{16}$ " to 1 & 2-Ton throat and $\frac{3}{32}$ " to 3-Ton hook throat.

FIGURE 4-4. HOOK THROAT OPENING

- j. Inspect hook for cracking, checking, extreme wear and spreading. Replace hooks showing these signs. Use dye penetrant, magnetic particle or other suitable crack detecting method. If the throat opening is spread wider than that listed in Figure 4-4, the hook has been overstressed and must be replaced.

- k. Inspect hook connections for cracks, bending, stripped threads, and other damage.

- l. Inspect limit switches for signs of looseness or deterioration. Ensure that they are securely mounted and that electrical connections are tight.

- m. Inspect all wiring and terminals for fraying and defective insulation. Check connections for tightness. Inspect crimp and insulation on terminal blocks.

- n. Inspect the supporting structure for continued ability to carry the rated loads.

- o. Inspect all nameplates, decals, and warning labels for security of attachment and legibility.

4-18. INSPECTION OF HOIST NOT IN REGULAR USE.

4-19. If a hoist has been idle for one month or more, but not more than six months, perform the inspections listed in paragraph 4-14 prior to use. If the hoist has been idle more than six months, perform the inspections listed in paragraph 4-16.

4-20. CLEANING.

4-21. The external surfaces of the hoist should be periodically wiped to remove deposits of dust, oily residue and other foreign material which tend to insulate the hoist from natural dissipation of heat. Be sure that capacity plate (10, Figure 7-1) and warning labels (24, Figure 7-8A; 24, Figure 7-8B; 24, Figure 7-8C; 24, Figure 7-8D; and 24, Figure 7-8E) are clean and legible from the operator's position. Keep wire rope, drum and load block clean at all times. Build up of foreign material or substances in these areas can bind, wear or otherwise restrict the wire rope and other moving parts. During periodic inspection and with hoist disconnected from its power supply, remove the control cover (2, Figure 7-1) and brake cover (1) and remove dust build up caused by electrical arcing and brake wear.

CAUTION

If cleaning solvents are used, provide adequate ventilation and be sure that fumes or vapors are safely dissipated before energizing the hoist. Wear protective clothing and avoid prolonged contact with solvent.

4-22. LUBRICATION.

4-23. Proper lubrication is necessary for a long and relatively trouble-free hoist operation. Refer to the following and to Figure 4-7, Recommended Lubrication Schedule, for lubrication points, type of lubricant and frequency of lubrication.

a. **WIRE ROPE.** Lubrication of the wire rope is important. The action within the rope as it moves over the drum or around the sheave is for the strands to slide one against the other. Lubrication will reduce this friction and prevent the entrance of moisture which can cause corrosion. Frequent light applications of lubricant is better than infrequent heavy applications. For best results, use Coffing Wire Rope Lubricant (Part No. 14J49), or other wire rope lubricant. As an alternative, use SAE 30 motor oil.

b. **Gearing:** The gear case of the hoist is filled at assembly with 1 gallon of a gear oil containing special friction-reducing additives.

WARNING

The use of gear oils other than that recommended in Figure 4-7 can cause brake chatter or can render the load brake incapable of holding a load. A 1 gallon container of this oil is available from the Duff-Norton Co. (Part No. 14J11).

a. To check the oil level, remove the $\frac{1}{8}$ " pipe plug from the side of the hoist. With the hoist hanging level, trans-

mission oil should be even with the edge of the tapped plug hole.

b. The length of time between necessary oil changes will depend on the severity of use the hoist receives. In general, the oil should be changed every 12 months of normal operation, or every 200 hours of actual hoist on-time. Very heavy use or operation in high ambient temperatures (over 105°F) will require that oil be changed more often. An indication of the need for oil replacement is load brake noise. If an erratic tapping sound is made when lowering a load, the oil should be changed.

c. **Limit Switch Shaft:** To prevent rust, the threaded limit switch shaft should be given a light coat of grease or sprayed with a general purpose lubricant.

d. **Hook Bearing:** Apply a few drops of SAE 30 oil around the edge of the bearing.

e. **BOTTOM BLOCK SHEAVE BUSHING.** Apply grease through grease fitting in sheave pin (14), Figure 7-9A or (10), Figure 7-9B).

f. **Trolley Gear Box:** At periodic inspections (see Figure 4-5) check grease level by removing end cap (22, Figure 7-12). The gear box should be approximately half full of grease. In general, the trolley gear box lubricant does not require changing.

g. **Trolley Wheel Gears:** Apply a light coat of grease to the pinion and both gears.

**INSPECTION & MAINTENANCE CHECK LIST
ELECTRIC POWERED OVERHEAD WIRE ROPE HOIST**

TYPE OF HOIST _____ CAPACITY (TONS) _____
 LOCATION _____ ORIGINAL INSTALLATION DATE _____
 MANUFACTURER _____ MANUFACTURER'S SERIAL NO. _____

ITEM	FREQUENCY OF INSPECTION			POSSIBLE DEFICIENCIES	OK	ACTION REQUIRED
	FREQUENT		PERIODIC 1-12 MO.			
	DAILY	MONTHLY				
Operating Controls	*	*	*	Any deficiency causing improper operation		
Limit Switches	*	*	*	Any deficiency causing improper operation Pitting or deterioration		
Disc (Motor) Brake	*	*	*	Slippage or excessive wear Glazing, contamination or excessive wear		
Load Brake (Mechanical)			*	Failure to support load with disc brake open (see Figure 4-8)		
Hooks	*	*	*	Excessive throat opening, bent or twisted more than 10 degrees, damaged hook latch, wear, chemical damage, worn hook bearing Cracks (use dye penetrant, magnetic particle or other suitable detection method)		
Suspension Lug			*	Cracks, excessive wear or other damage which may impair the strength of the lug Cracks (use dye penetrant, magnetic particle or other suitable detection method)		
Wire Rope	*	*	*	Inadequate lubrication, wear, twist, distortion, improper dead-ending, deposits of foreign substance Deterioration or wear resulting in appreciable loss of original strength		
Suspension Lug Connections			*	Cracks, bending, stripped threads, damaged suspension studs		
Pins, Bearings, Bushings, Shafts Couplings, Gears			*	Excessive wear, corrosion, cracks, distortion		
Nuts, Bolts, Rivets			*	Looseness, stripped and damaged threads, corrosion		
Sheave, Drum			*	Distortion, cracks, and excessive wear Build up of foreign substances		
Housings, Load Block			*	Cracks, distortion, excessive wear, Internal build up of foreign substances		
Wiring and Terminals			*	Fraying, defective insulation		
Contact Block, Magnetic Hoist Control Switch, Other Electrical Apparatus			*	Loose connections, burned or pitted contacts		
Supporting Structure and Trolley (if used)			*	Damage or wear which restricts ability to support imposed loads		
Nameplates, Decals, Warning Labels			*	Missing, damaged or illegible		
Transmission Lubricant			*	Low Level, Requires Changing		

NOTE: Refer to Maintenance and Inspection Sections of the Hoist Maintenance Manual for further details.

FREQUENCY OF INSPECTION:

Frequent— Indicates items requiring inspection daily to monthly. Daily inspections may be performed by the operator if properly designated.

Periodic— Indicates items requiring inspection monthly to yearly. Inspections to be performed by or under the direction of a properly designated person. The exact period of inspection will depend on frequency and type of usage. Determination of this period will be based on the user's experience. It is recommended that the user begin with a monthly inspection and extend the periods to quarterly, semi-annually or annually based on his monthly experience.

FIGURE 4-5. RECOMMENDED INSPECTION AND MAINTENANCE CHECK LIST

NOTE: This inspection and maintenance check list is in accordance with our interpretation of the requirements of Safety Standard for Overhead Hoists ANSI B30.16. It is, however, the ultimate responsibility of the employer/user to interpret and adhere to the applicable requirements of this safety standard.

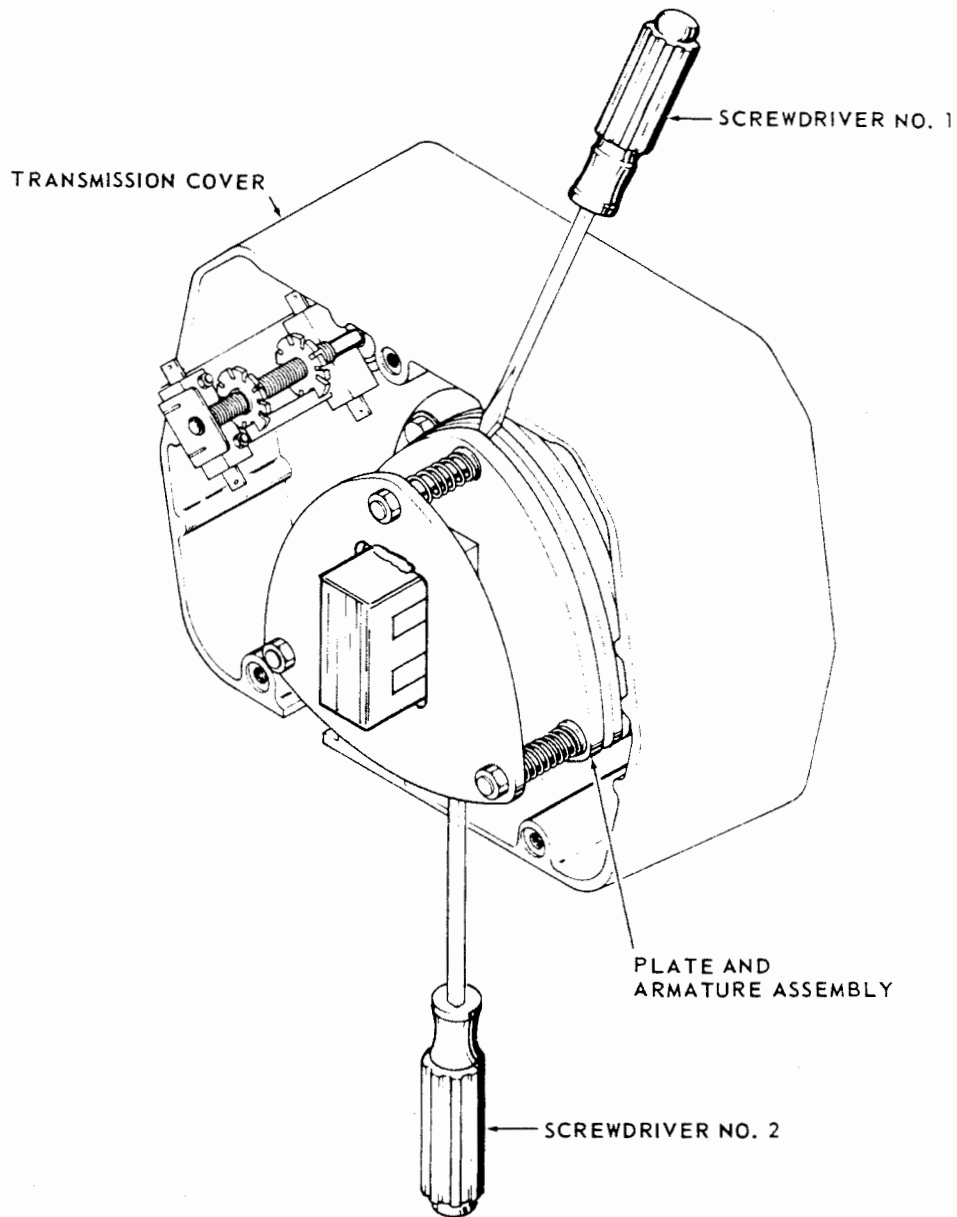

To check function of Load Brake, proceed as follows: Attach a light load to hoist and lift load several inches. DISCONNECT HOIST FROM POWER SUPPLY and remove brake cover (1, Figure 7-1). Referring to illustration above and Figure 7-7, place screwdrivers No. 1 and No. 2 behind the plate and armature assembly and prepare to pry against transmission cover. Do not allow either screwdriver to contact the brake disc (7, Figure 7-7A or 7-7B). Carefully pry open motor brake (close solenoid gap) and observe action of load. If the load descends, the load brake is malfunctioning and must be repaired.

FIGURE 4-8. LOAD BRAKE FUNCTION CHECK

SECTION V TROUBLESHOOTING

5-1. GENERAL.

5-2. Use the following table as an aid to troubleshoot the hoist. If you do not have an experienced machinist-electrician to do your repair work, we recommend that

you send your hoist to an approved service center or to us for repairs.

TROUBLE	REMEDY
HOOK FAILS TO STOP AT END OF TRAVEL	
<ol style="list-style-type: none"> 1. Motor brake needs adjustment 2. Limit switches not operating 3. Plastic limit switch nuts not moving on shaft 4. Magnetic reversing switch malfunction 5. 3 Phase reversal 	<ol style="list-style-type: none"> 1. See paragraph 4-5. 2. Check adjustment. See paragraph 4-1. Check connections against wiring diagram. Tighten loose connections or replace. 3. Check for stripped threads or bent nut guide. 4. Remove control cover and check reversing switch. 5. Reverse any two wires (except the green ground wire) at the power source.
HOIST DOES NOT RESPOND TO PUSHBUTTON	
<ol style="list-style-type: none"> 1. Power failure in supply lines 2. Wrong voltage or frequency 3. Improper connections in hoist or pushbutton station 4. Motor brake does not release 5. Faulty magnetic hoist control switch 	<ol style="list-style-type: none"> 1. Check circuit breakers, switches, and connections in power supply lines. 2. Check voltage and frequency of power supply against the rating on the nameplate of the hoist. 3. Check all connections at line connectors and on terminal block. Check terminal block on dual-voltage hoists for proper voltage connections. 4. Check connections to the solenoid coil. Check for open or short circuit. Check for proper adjustment. See paragraph 4-5. Check for burned out coil. 5. Check coils for open or short circuit. Check all connections in control circuit. Check for burned contacts. Replace as needed.
HOOK DOES NOT STOP PROMPTLY	
<ol style="list-style-type: none"> 1. Hoist overloaded 2. Motor brake not holding 	<ol style="list-style-type: none"> 1. Reduce load to within rated capacity of hoist. 2. Check motor brake adjustment. See paragraph 4-5 and Figure 4-2.
HOOK MOVES IN WRONG DIRECTION	
<ol style="list-style-type: none"> 1. Three-phase reversal 2. Improper connections 	<ol style="list-style-type: none"> 1. Reverse any two wires (except the green ground wire) at the power source (see paragraph 2-8). 2. Check all connections against Wiring Diagram.
HOIST HESITATES TO LIFT WHEN ENERGIZED	
<ol style="list-style-type: none"> 1. Hoist overloaded 2. Motor brake requires adjustment 3. Worn load equalizer clutch 4. Low voltage 	<ol style="list-style-type: none"> 1. Reduce load within rated capacity of hoist. 2. Check motor brake adjustment, see paragraph 4-5. 3. Replace clutch. 4. Check voltage, see paragraph 2-3a.

TROUBLE**REMEDY****MOTOR BRAKE "NOISE" OR CHATTER**

<ol style="list-style-type: none"> Needs adjustment Broken shading coil element 	<ol style="list-style-type: none"> Adjust per paragraph 4-5. Replace shading coil element.
---	--

HOOK RAISES BUT WILL NOT LOWER

<ol style="list-style-type: none"> "Down" circuit open Broken conductor in pushbutton cable Faulty magnetic hoist control switch 	<ol style="list-style-type: none"> Check circuit for loose connections. Check "Down" limit switch for malfunction. Check each conductor in the cable. If one is broken, replace entire cable. Check coils for open or short circuit. Check all connections in control circuit. Check for burned contacts. Replace as needed.
---	---

HOOK RAISES BUT WILL NOT LOWER WHEN MOTOR IS OPERATING

CONSULT FACTORY OR AUTHORIZED DUFF-NORTON WARRANTY REPAIR STATION.

HOOK LOWERS BUT WILL NOT RAISE

<ol style="list-style-type: none"> Hoist overloaded Low voltage "UP" circuit open Broken conductor in pushbutton cable Faulty magnetic hoist control switch Worn load equalizer clutch 	<ol style="list-style-type: none"> Reduce load to within rated capacity. Determine cause of low voltage and bring up to within plus or minus 10 per cent of the voltage specified on hoist. Line voltage should be measured while hoist is lifting load. Check circuit for loose connections. Check "UP" limit switch for malfunctions. Check each conductor in the cable. If one is broken, replace entire cable. Check coils for open or short circuit. Check all connections in control circuit. Check for burned contacts. Replace as needed. Replace clutch.
--	---

LACK OF PROPER LIFTING SPEED

<ol style="list-style-type: none"> Hoist overloaded Motor brake is dragging Low voltage Load equalizer clutch intermittently slipping 	<ol style="list-style-type: none"> Reduce load to within rated capacity of hoist. Check for proper brake adjustment or other defects. See paragraph 4-5. Bring up voltage to plus or minus 10 per cent of voltage specified on hoist. Line voltage should be measured while hoist is lifting load. Replace clutch.
---	--

LOAD BRAKE "NOISE" (ERRATIC TAPPING SOUNDS OR SQUEALS)

<ol style="list-style-type: none"> Need transmission oil change or improper lubricant has been used Load brake malfunctioning 	<ol style="list-style-type: none"> Change transmission oil. See Figure 4-7. Note: Hoist Warranty is void if unapproved oil is used. Check load brake operation. See Figure 4-8.
---	---

EXCESSIVE WIRE ROPE WEAR

<ol style="list-style-type: none"> Lack of lubrication Excessive side loading Worn sheaves 	<ol style="list-style-type: none"> Lubricate wire rope. Reduce side loading to allow wire rope to wind smoothly on drum. Check for worn or corrugated sheaves in bottom block or idler sheave in hoist. Replace as needed.
---	---

SECTION VI WIRING DIAGRAMS

Safety Notes

Disconnect power from hoist before removing end covers.

6-1. Voltage Conversion

Standard single speed three phase units are convertible from 460 to 230 volts. Conversion to the alternate voltage can be accomplished with the following procedure.

- a. Be sure power is disconnected from hoist. Remove long end cover.
- b. Transfer leads T4, T5, T6, T7, T8, T9, H2, H3, S1, and S2 per the appropriate terminal block schematic.

CAUTION

Do not move any wires or make any changes to the wiring except at the terminal block.

- c. After converting voltage, check for proper phasing of three phase units and check for proper limit switch operation.

6-2. Wiring Diagrams

The wiring diagrams for standard hoist models are reproduced on the following pages. In addition, every hoist should have a wiring diagram located inside the long end cover.

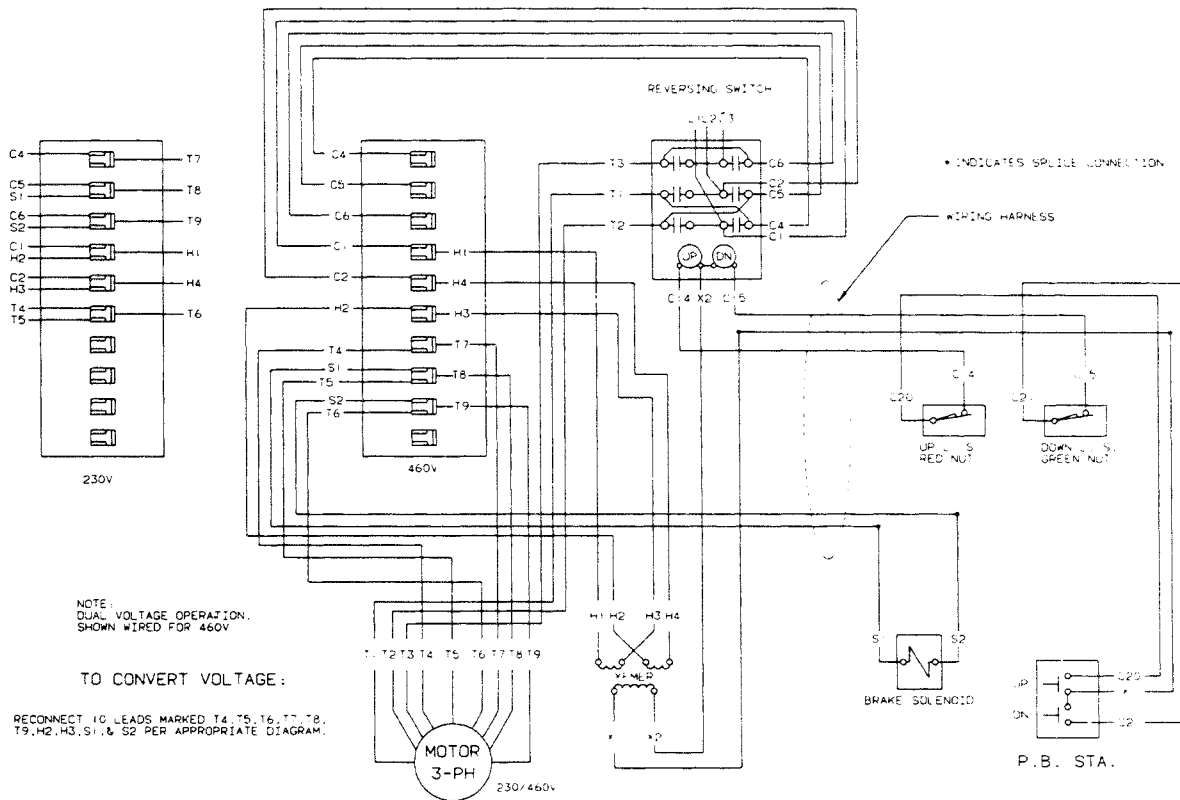

**FIGURE 6-1. WIRING DIAGRAM
230/460V, 3 Phase, Single Speed Hoist
983EC44C**

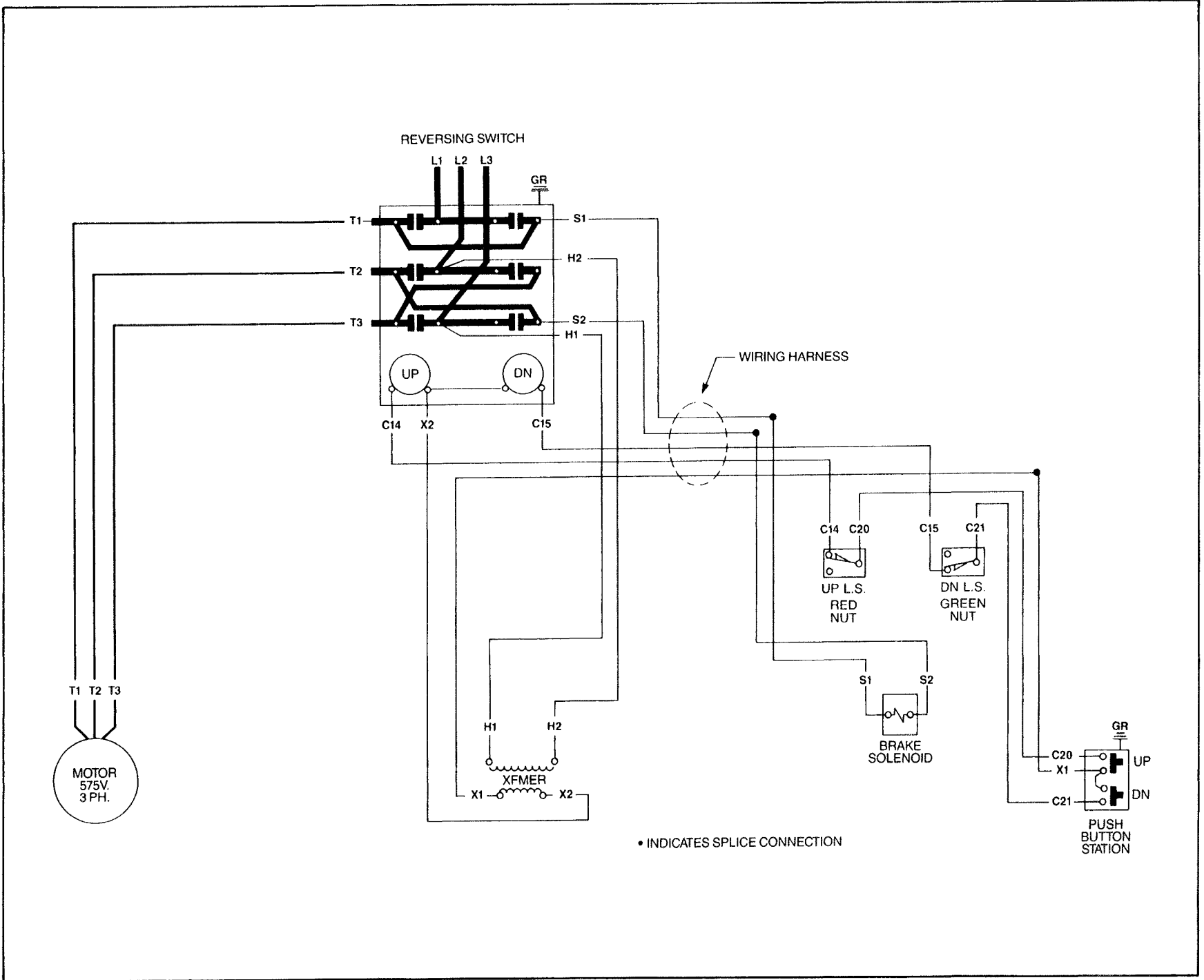

FIGURE 6-2. WIRING DIAGRAM
575V, 3 Phase, Single Speed Hoist
983EC45

**FIGURE 6-3. WIRING DIAGRAM
208V, 3 Phase Single Speed Hoist
983EC48**

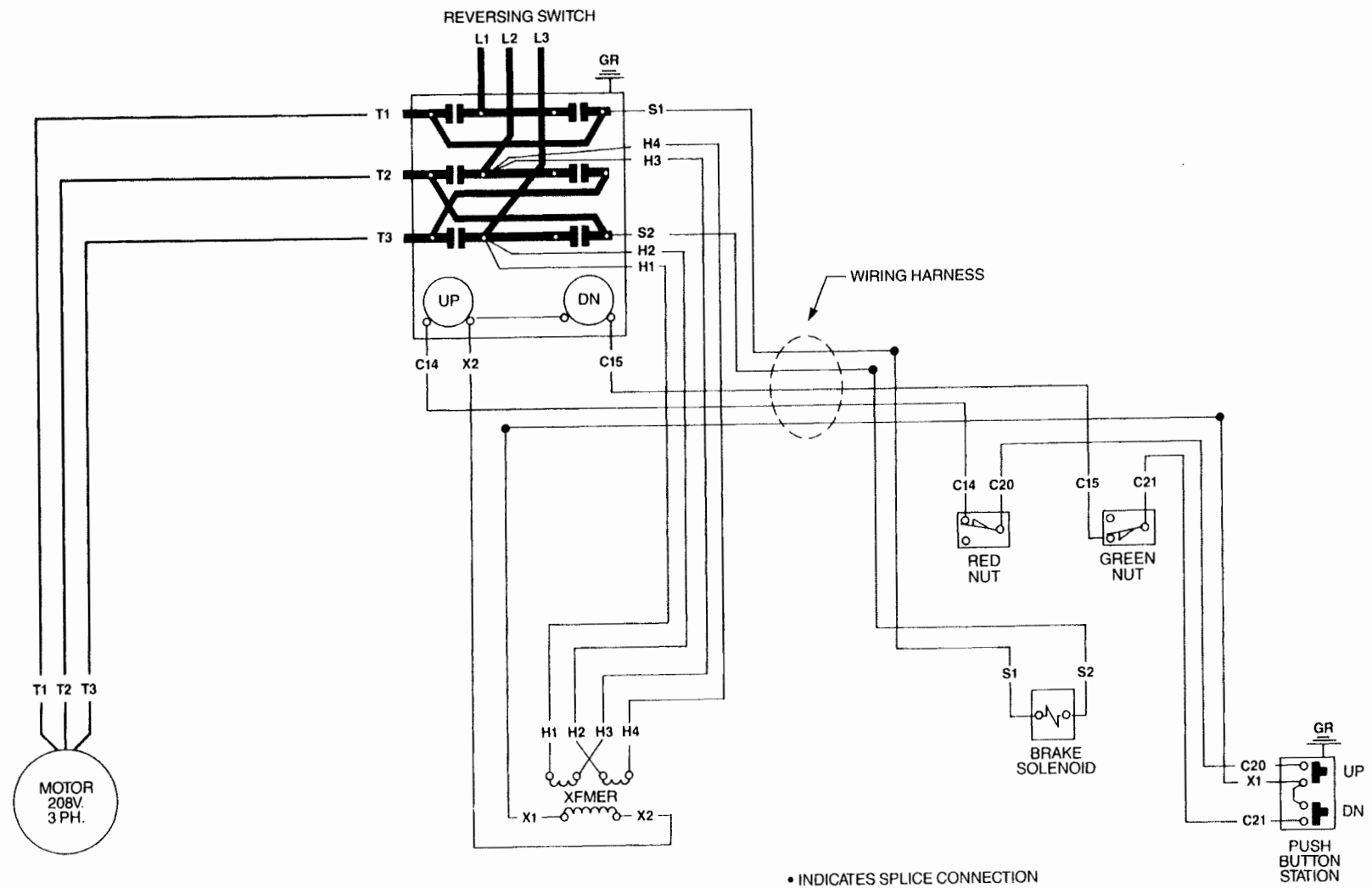
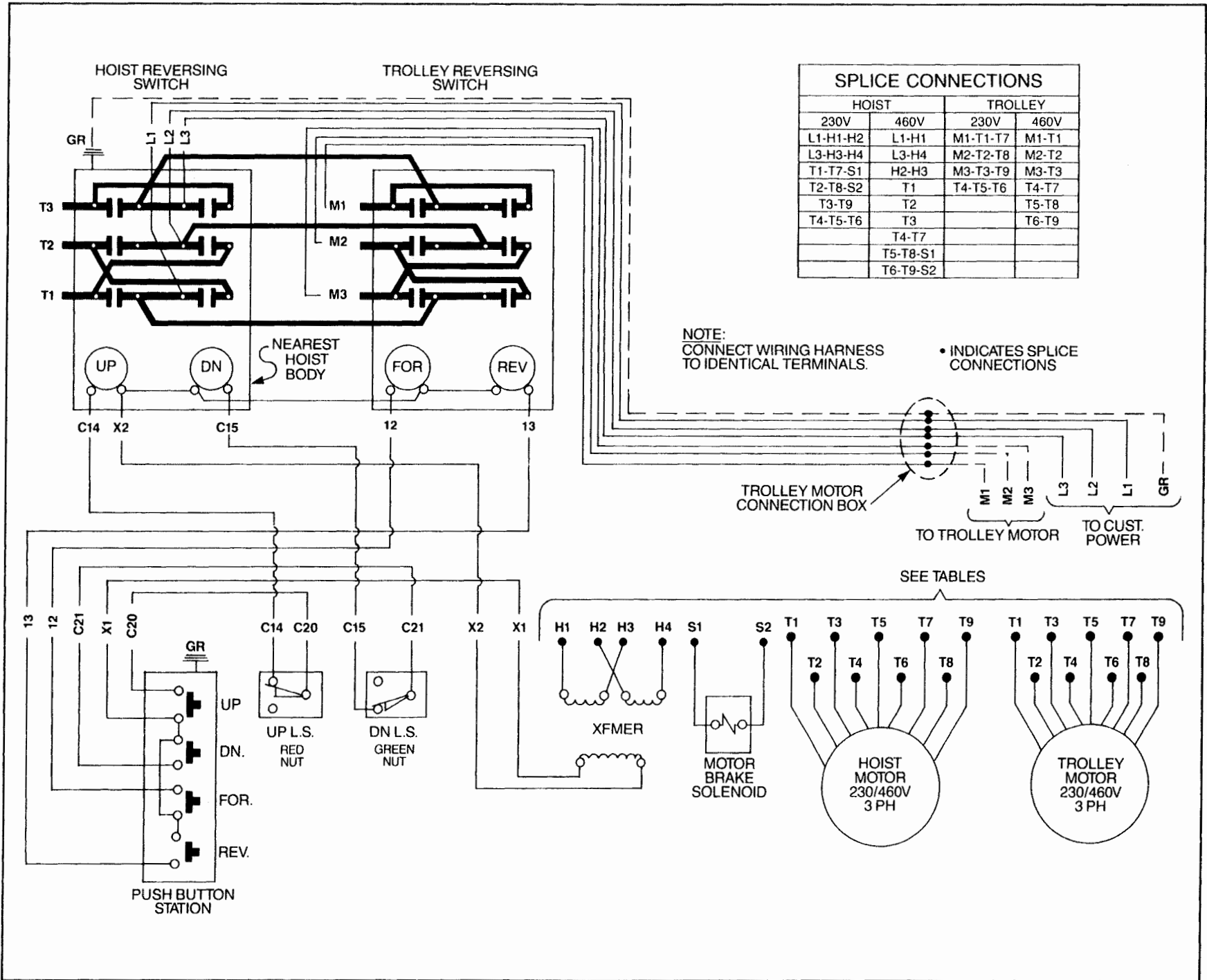

FIGURE 6-5. WIRING DIAGRAM
230/460 V, 3 Phase Single Speed Hoist & Single Speed Trolley
983ECMT1



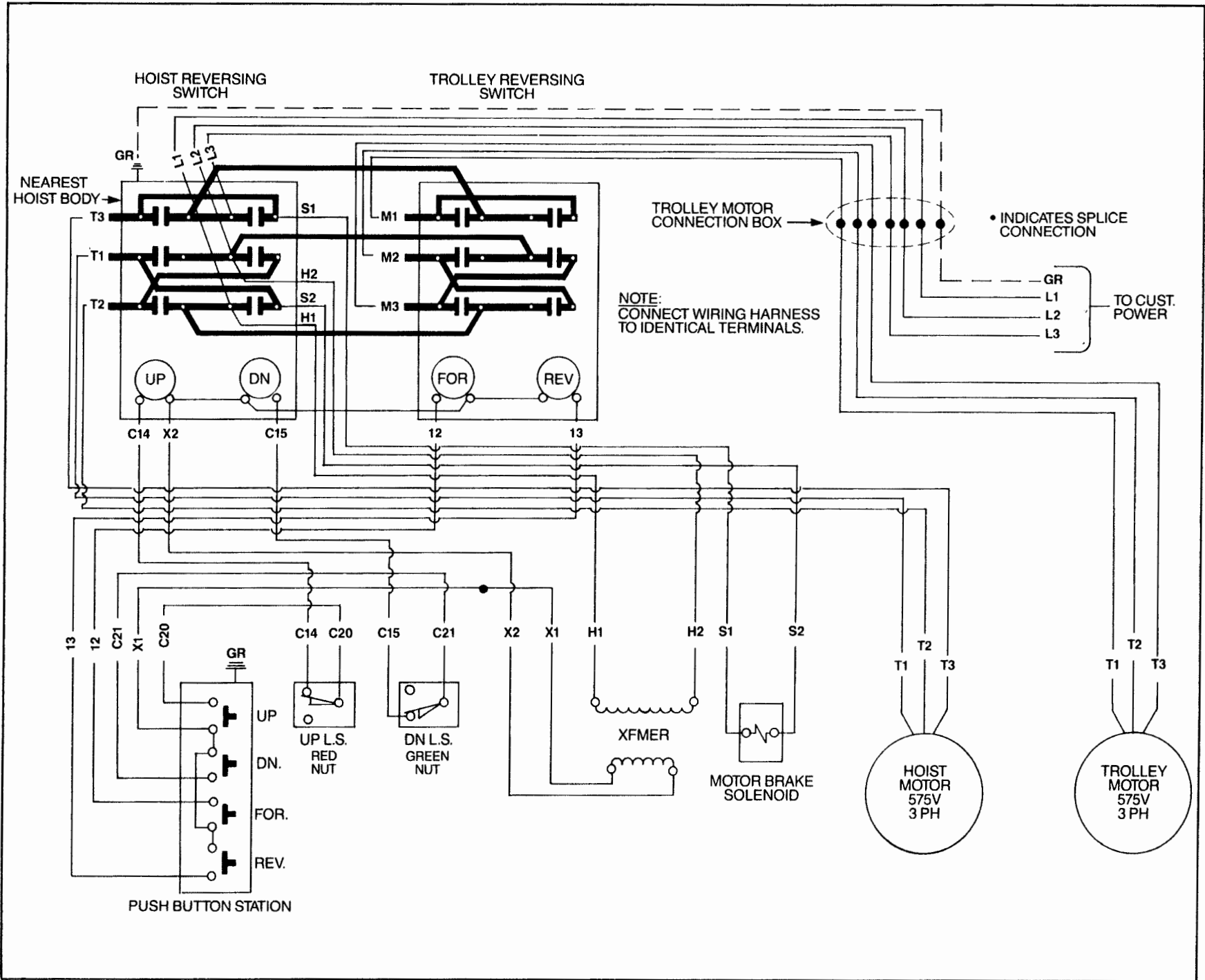
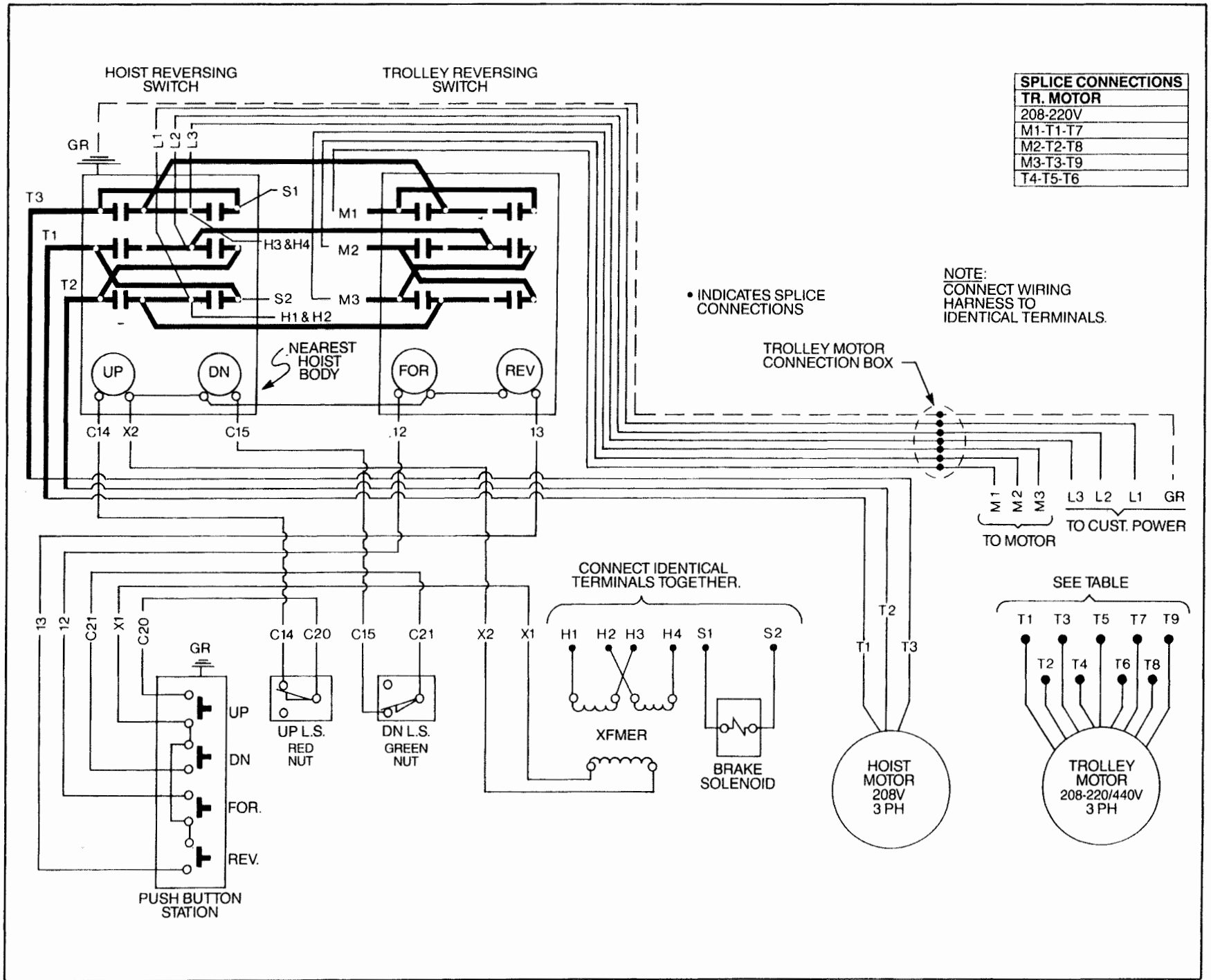
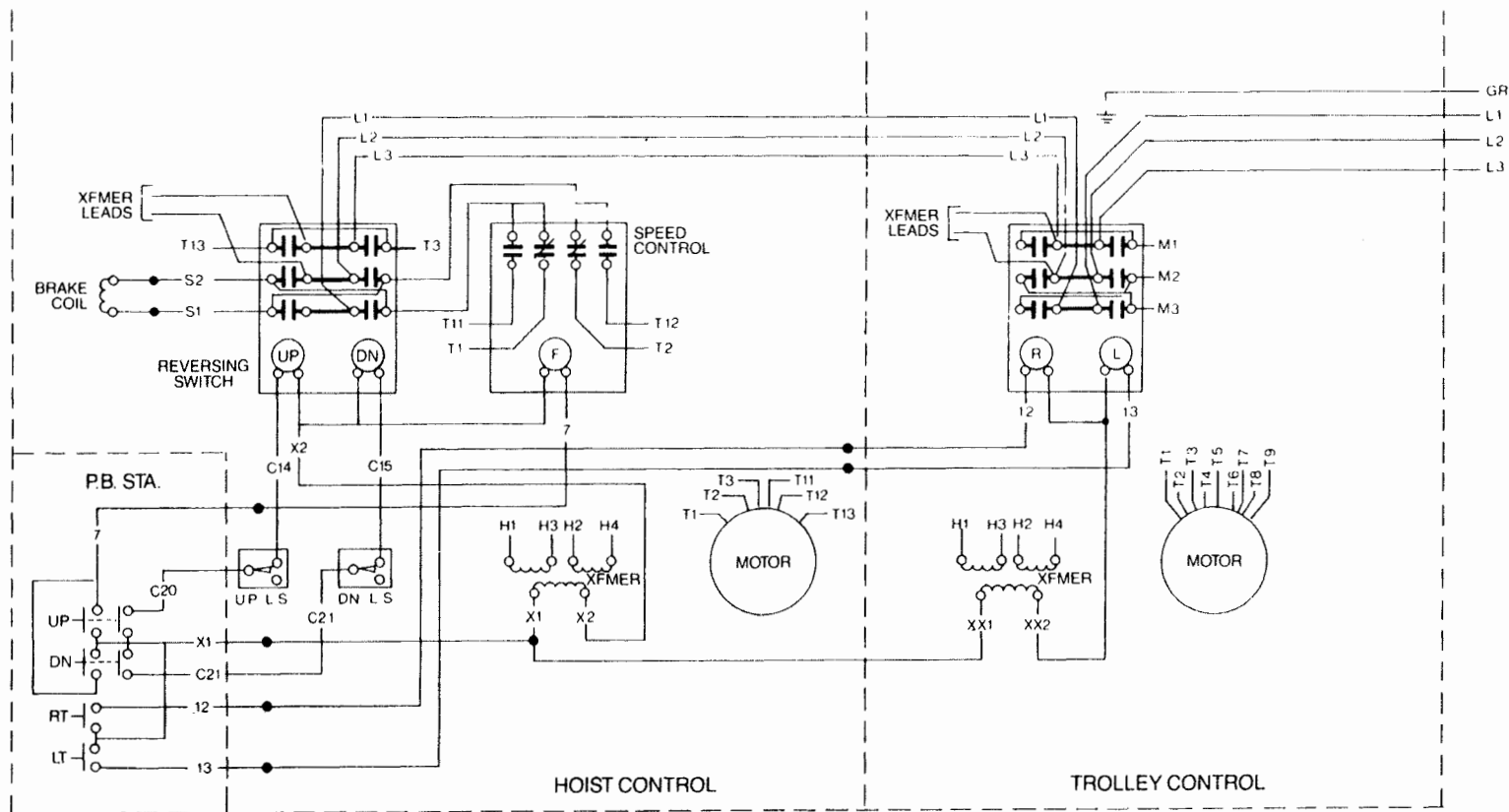

FIGURE 6-6. WIRING DIAGRAM
575V, 3 Phase, Single Speed Hoist & Single Speed Trolley
983ECMT2

FIGURE 6-7. WIRING DIAGRAM
208V, 3 Phase Single Speed Hoist & Single Speed Trolley
983ECMT27





• IN-LINE SPLICE

TRANSFORMER CONNECTIONS		
208 or 230 V	460 V	575 V
L2-H1-H2	L2-H1	L2-H1
L3-H3-H4	L3-H4	L3-H2
	H2-H3	(NO H3, H4)

TROLLEY MOTOR CONNECTIONS		
208 or 230 V	460 V	575 V
M1-T1-T7	M1-T1	M1-T1
M2-T2-T8	M2-T2	M2-T2
M3-T3-T9	M3-T3	M3-T3
T4-T5-T6	T4-T7	(NO T4-T9)
	T5-T8	
	T6-T9	

FIGURE 6-8. WIRING DIAGRAM
230, 460, 575 & 208V, 3 Phase
Two Speed Hoist & Single Speed Trolley
983ECMT268

FIGURE 6-9. WIRING DIAGRAM
230, 460V, 3 Phase, Single Speed Hoist & Two Speed Trolley
983ECMT269A

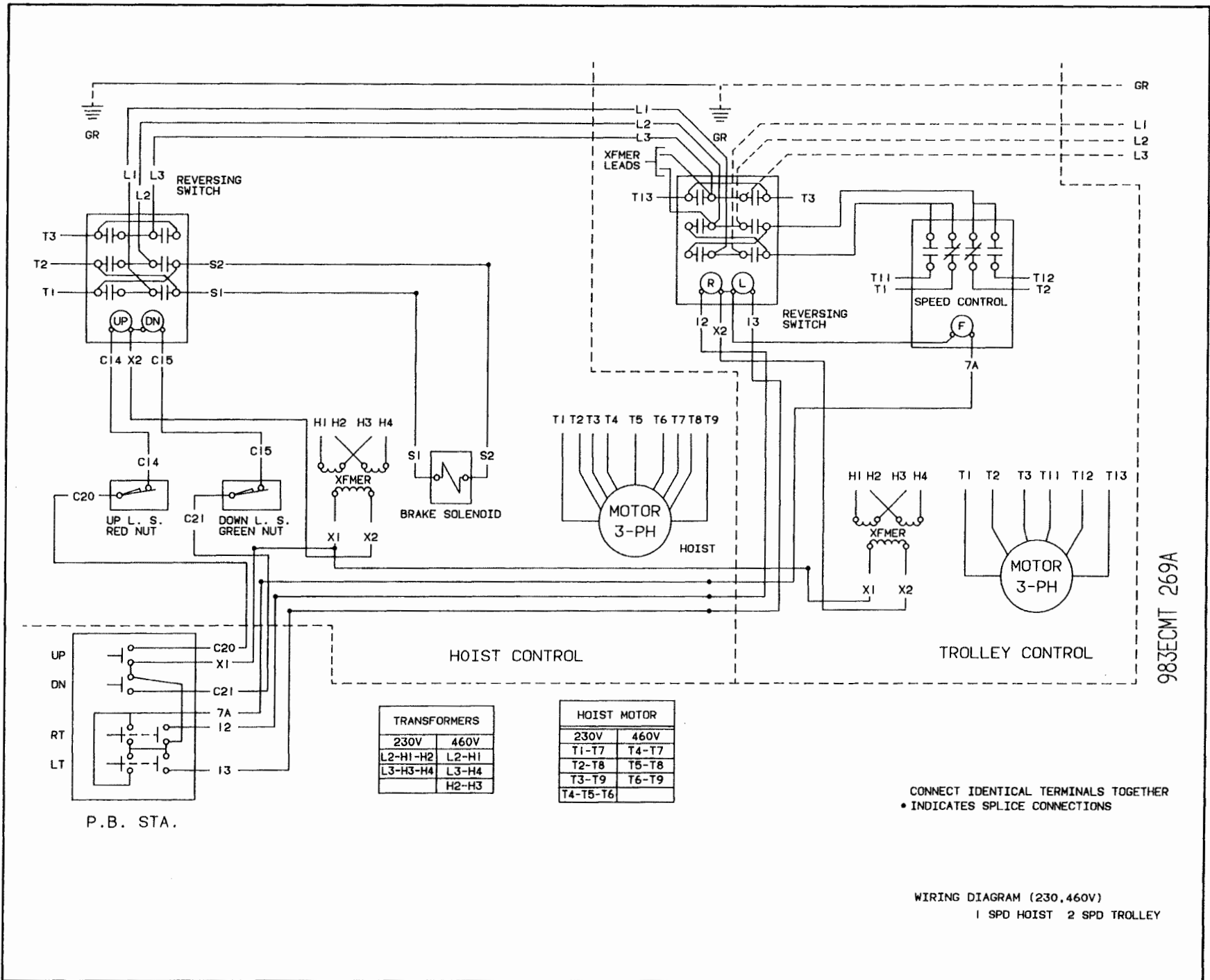

983ECMT 269A

TRANSFORMERS	
230V	460V
L2-H1-H2	L2-H1
L3-H3-H4	L3-H4
	H2-H3

HOIST MOTOR	
230V	460V
T1-T7	T4-T7
T2-T8	T5-T8
T3-T9	T6-T9
T4-T5-T6	

CONNECT IDENTICAL TERMINALS TOGETHER
 • INDICATES SPLICE CONNECTIONS

WIRING DIAGRAM (230,460V)
 1 SPD HOIST 2 SPD TROLLEY

P.B. STA.

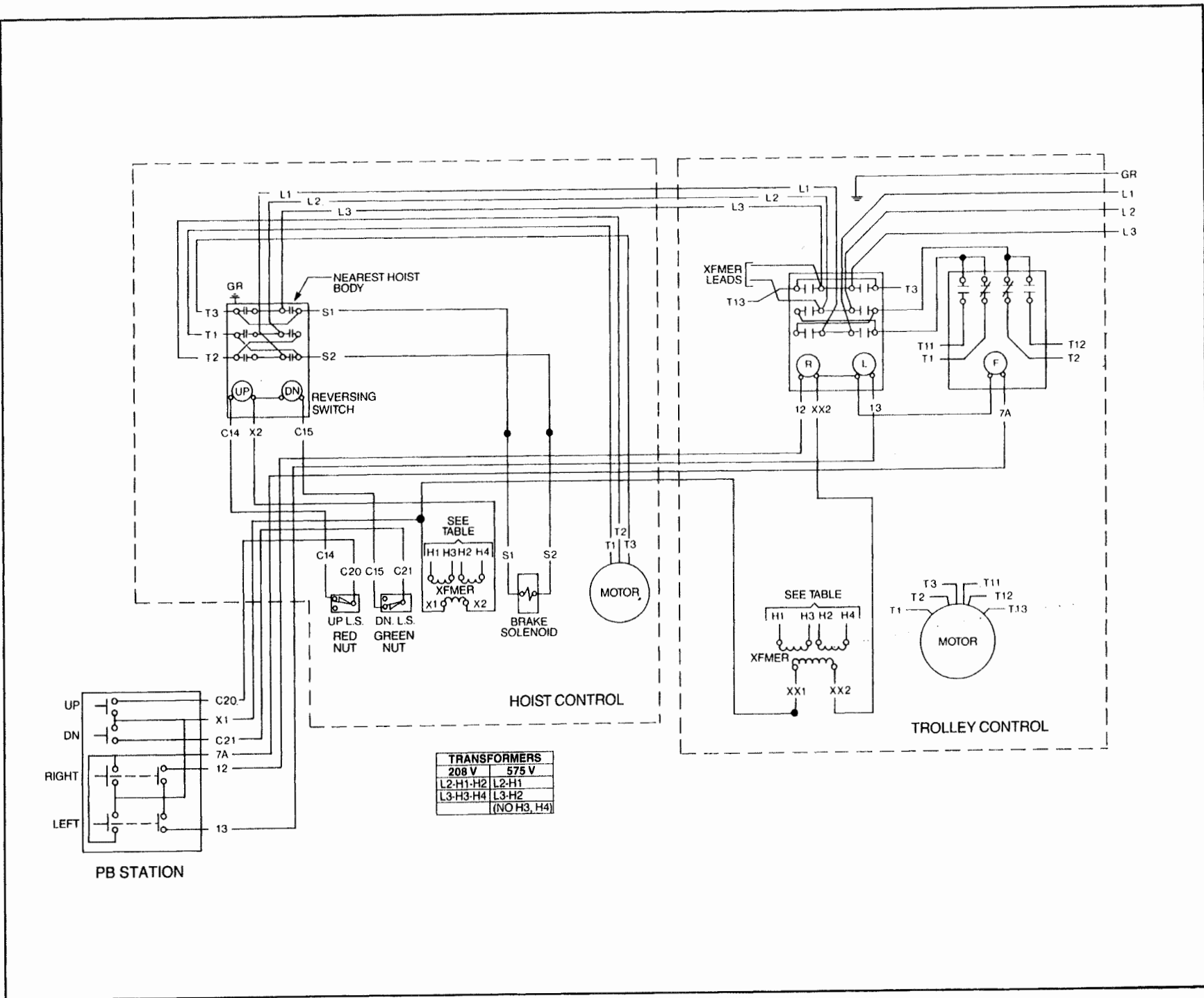
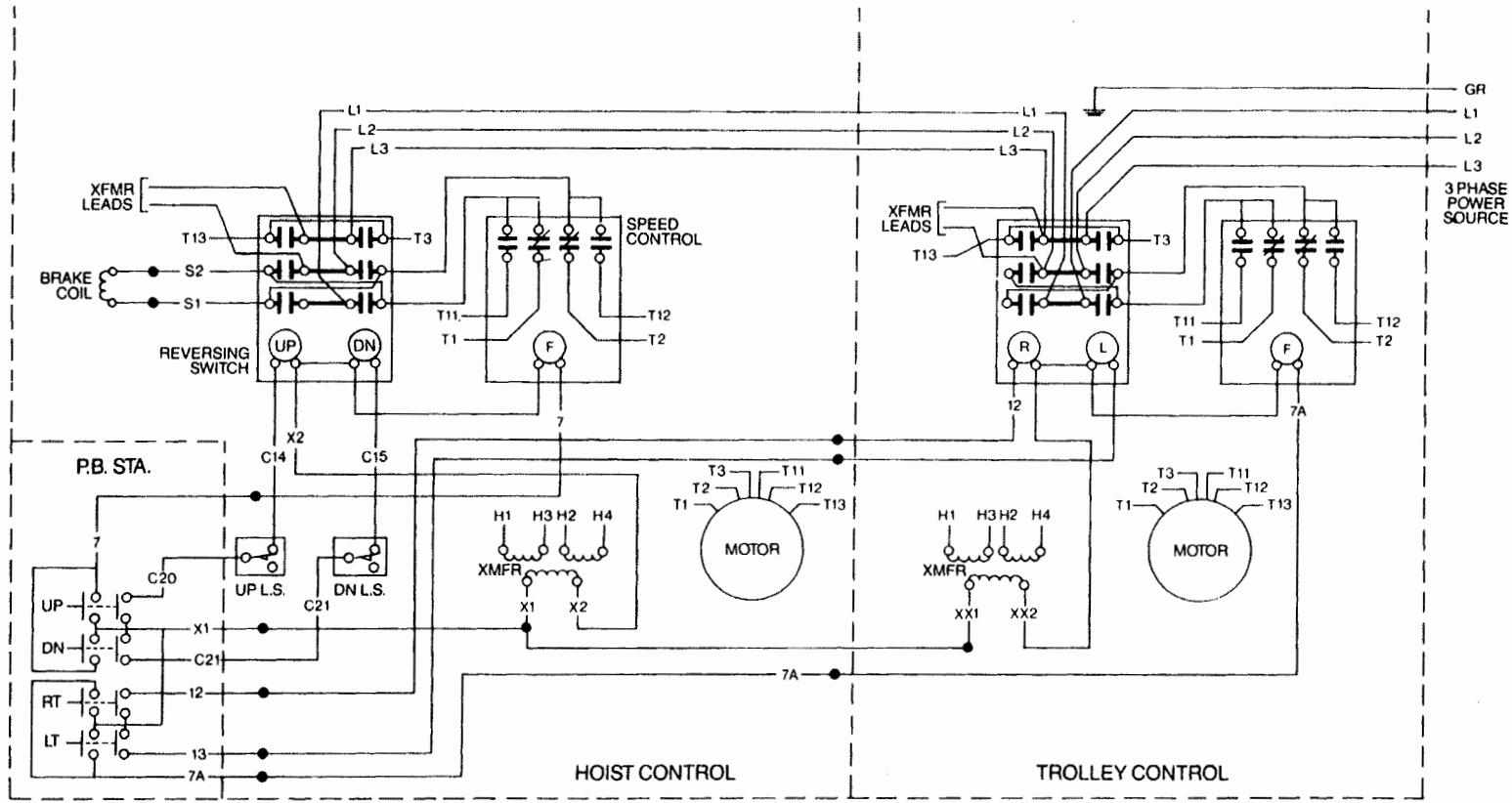

FIGURE 6-10. WIRING DIAGRAM
 208, 575V, 3 Phase, Single Speed Hoist & Two Speed Trolley
 983ECMT270



• IN-LINE SPLICE

TRANSFORMER CONNECTIONS		
208 or 230 V	460 V	575 V
L2-H1-H2	L2-H1	L2-H1
L3-H3-H4	L3-H4	L3-H2
	H2-H3	(NO H3, H4)

FIGURE 6-11. WIRING DIAGRAM
230, 460, 575 & 208V, 3 Phase, Two Speed Hoist & Two Speed Trolley
983ECMT271

SECTION VII ILLUSTRATED PARTS LISTS

7-1. GENERAL.

7.2. The illustrated parts lists that follow are designed to help you identify the parts of your Coffing hoist and trolley. Several different models of hoists and trolleys are covered by this manual and differences will be noted between your hoist and the illustrations contained herein. However, the parts list will show the correct replacement part for your model hoist.

7-3. HOW TO USE THE PARTS LISTS.

7.4. To identify a part from your hoist, locate the figure which illustrates that area of the hoist where your part is located. Example: The brake coil would be located in the Motor Brake Figures. At this time, it may be necessary to take into consideration certain characteristics of your hoist. Due to configuration differences, it was necessary to divide this area according to hoist motor horsepower. Therefore, when determining the figure in which your

part would be illustrated, be sure the figure applies to **your** hoist or trolley. Study the illustration and locate the part you wish to find. A number will be found adjacent to the part; this number, which is the index number, will be found in the accompanying parts list with the part name and part number.

When ordering parts, please give the following information:

1. Model and serial number of your hoist.
2. Total lift of your hoist.
3. Your power supply (voltage, phase, cycles).
4. Desired part number and part name.

The serial and model numbers for your hoist are permanently stamped on the motor adaptor casting.

See the illustration below.

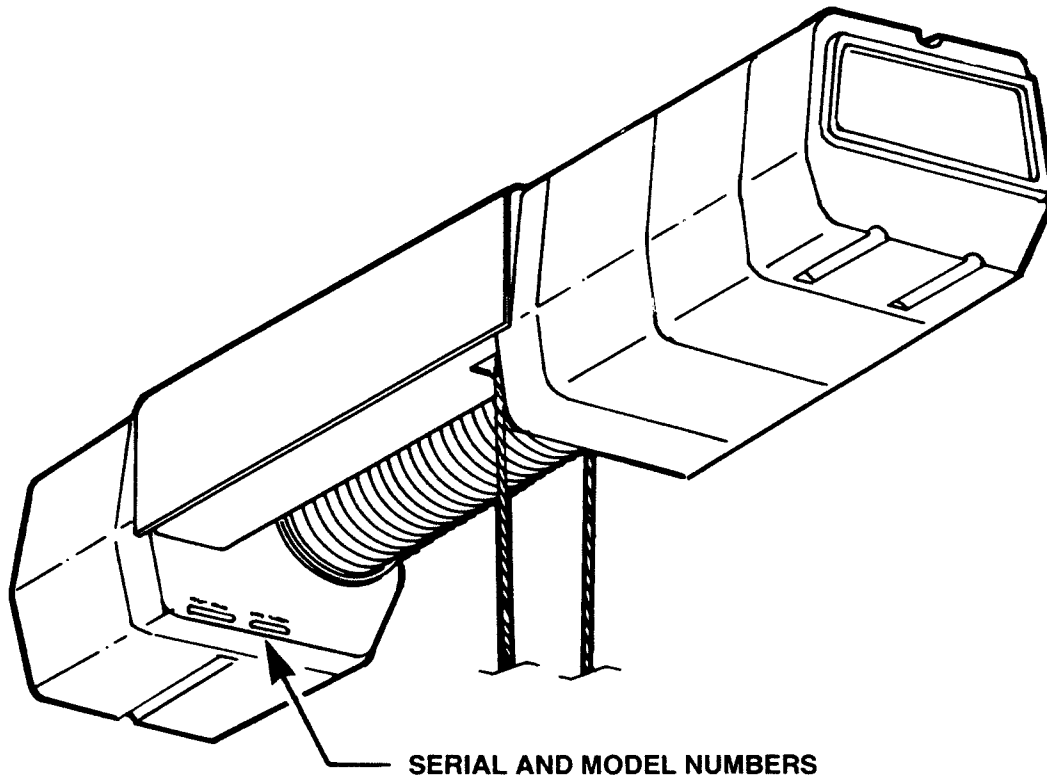

EXAMPLE:

Serial Number: WR3-B-101-SFD

Model Number: WR-4021

7-5. WARRANTY.

Every hoist is thoroughly inspected and tested prior to shipment from the factory. Should any problems develop, return the complete hoist prepaid to your nearest Duff-Norton Authorized Warranty Repair Station. If inspection reveals that the problem is caused by defective workmanship or material, repairs will be made without charge and the hoist will be returned, transportation prepaid.

This warranty does not apply where: (1) deterioration is caused by normal wear, abuse, improper or inadequate power supply, eccentric or side loading, overloading, chemical or abrasive actions, improper maintenance or excessive heat; (2) problems resulted from repairs,

modifications or alterations made by persons other than factory or Duff-Norton Authorized Warranty Repair Station personnel; (3) the hoist has been abused or damaged as a result of an accident; (4) repair parts or accessories other than those supplied by Duff-Norton are used on the hoist. Equipment and accessories not of the seller's manufacture are warranted only to the extent that they are warranted by the manufacturer. EXCEPT AS STATED HEREIN, DUFF-NORTON MAKES NO OTHER WARRANTIES, EXPRESS OR IMPLIED, INCLUDING WARRANTIES OF MERCHANTABILITY AND FITNESS FOR A PARTICULAR PURPOSE.

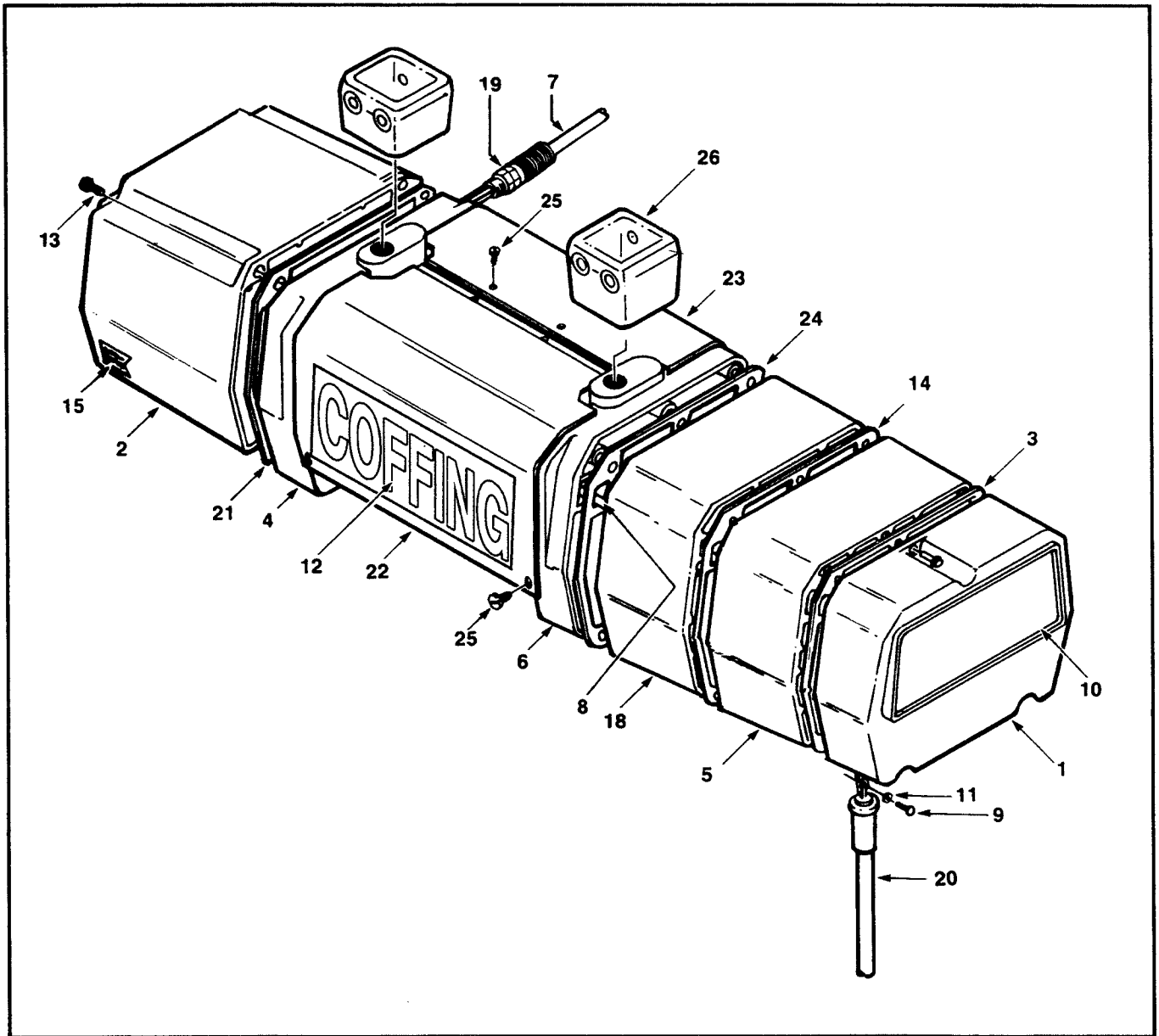
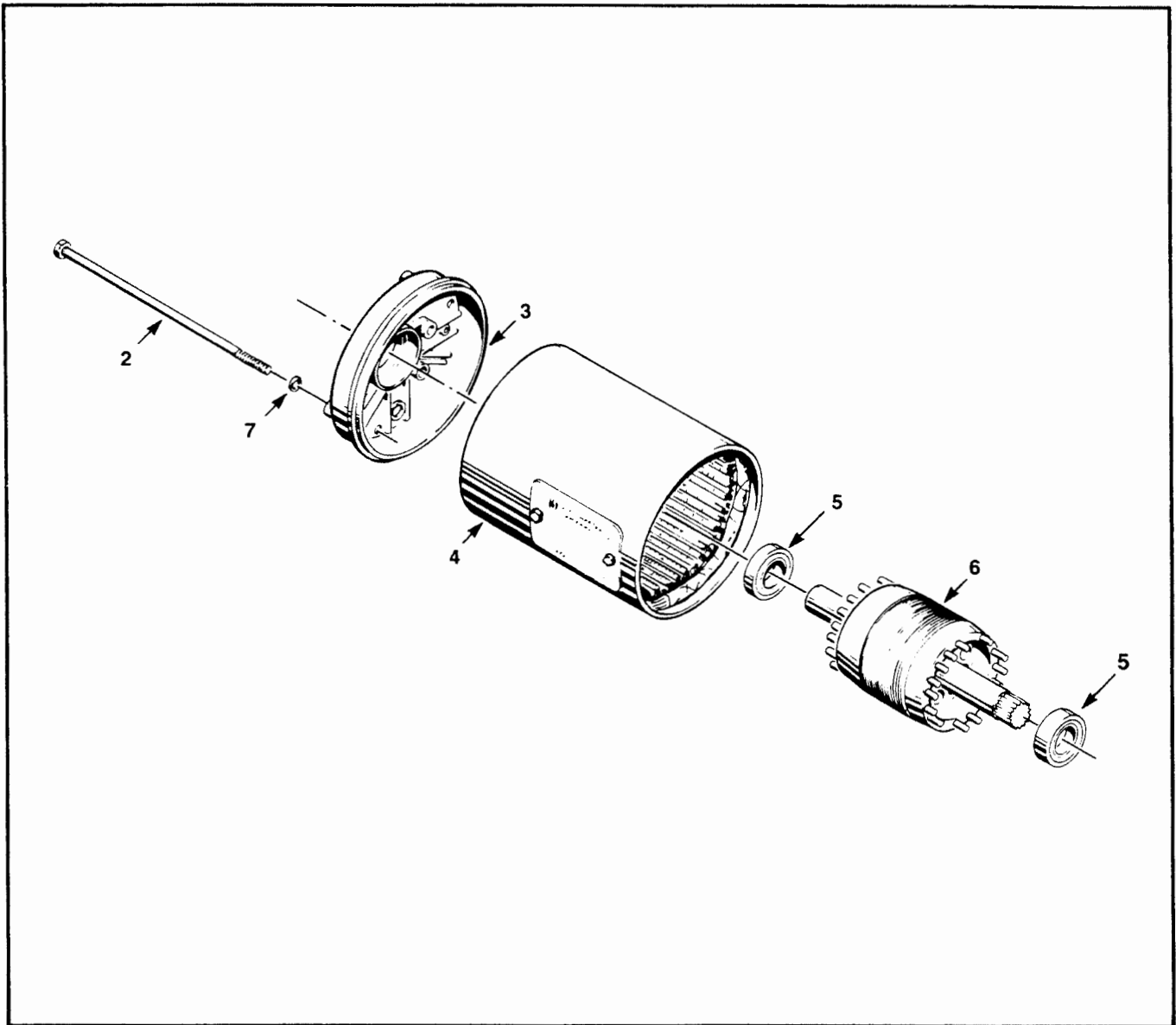

FIGURE 7-1. BASIC HOIST

Index No.	Part Name	Part No.	Index No.	Part Name	Part No.
1	Brake Cover	36J4	13	Screw, End Covers	H-2987-P
2	Control Cover	36J3	14	Gasket, Transmission Cover	560J6
3	Gasket, Brake Cover	560J2	15	Decal, Duff-Norton	676J2B
4	Motor Adapter: 1 & 2-Ton	39J4-2	16*	Decal, Power Requirements: 230/460V	679J2
	3-Ton	39J4		230V	679J3
5	Transmission Cover	34J2		460V	679J4
6	Transmission Adapter: 1 & 2-Ton	37J7-2		575V	679J5
	3-Ton	37J7		208V	679J6
7	Power Cable Assembly (15 foot length)	953KG2-15	18	Transmission Housing	35J3
			19	Cord Grip	H-7961
8	Wiring Harness: 1 & 2-Ton, 22 Ft. Lift, Single Speed	940J7	20	Pushbutton Cable (See Fig. 7-8)	
	1 & 2-Ton, 35 Ft. Lift, Single Speed	940J8	21	Gasket, Control Cover	560J3
	1 & 2-Ton, 44 Ft. Lift, Single Speed	940J9	22	Cover (Tube Side): 1 & 2-Ton, 22 Ft. Lift,	270J4-1
	3-Ton, 22 Ft. Lift, Single Speed	940J9		1 & 2-Ton, 35 Ft. Lift	270J4-2
	1 & 2-Ton, 22 Ft. Lift, Two Speed	940J7-1		1 & 2-Ton, 44 Ft. Lift	270J4-3
	1 & 2-Ton, 35 Ft. Lift, Two Speed	940J8-1		3 Ton, 22 Ft. Lift	270J4-3
	1 & 2-Ton, 44 Ft. Lift, Two Speed	940J9-1		Any Other Lift	Not Available
	3-Ton, 22 Ft. Lift, Two Speed	940J9-1	23	Cover (Drum Side): 1 & 2-Ton, 22 Ft. Lift	270J3-1
	Any Other Lift	Consult Factory		1 & 2-Ton, 35 Ft. Lift	270J3-2
9	Screw	H-2981-P		1 & 2-Ton, 44 Ft. Lift	270J3-3
10	Decal, Capacity: 1-Ton	675J3B		3 Ton, 22 Ft. Lift	270J3-3
	2-Ton	675J5	24	Any Other Lift	Not Available
	3-Ton	675J6	25	Gasket, Transmission Adapter	560K15
11	Washer, Plain	H-4002-P	26	Screw, Cover	H-2970
12	Decal, Coffing	677J2		Suspension Box (See Fig. 7-5)	

*Not Illustrated

FIGURE 7-1. BASIC HOIST



Index No.	Part Name	Part No.	Index No.	Part Name	Part No.
1	Motor Complete:			Single Speed - 208V	863J406
	2 H.P. Motor			Two Speed - 230V	873J402
	Single Speed - 230/460V	863J401		Two Speed - 460V	873J404
	Single Speed - 575V	863J403		Two Speed - 575V	873J406
	Single Speed - 208V	863J405		Two Speed - 208V	873J408
	Two Speed - 230V	873J401	2	Thru Bolt	*
	Two Speed - 460V	873J403	3	End Shield	*
	Two Speed - 575V	873J405	4	Stator	
	Two Speed - 208V	873J407		(Not available separately)	*
	3 H.P. Motor		5	Bearing	*
Single Speed-230/460V	863J402	6	Rotor & Shaft Assembly	*	
Single Speed - 575V	863J404	7	Lock Washer	*	

*For individual motor parts, contact your Duff-Norton Distributor and supply complete motor nameplate data.

FIGURE 7-2. HOIST MOTOR PARTS

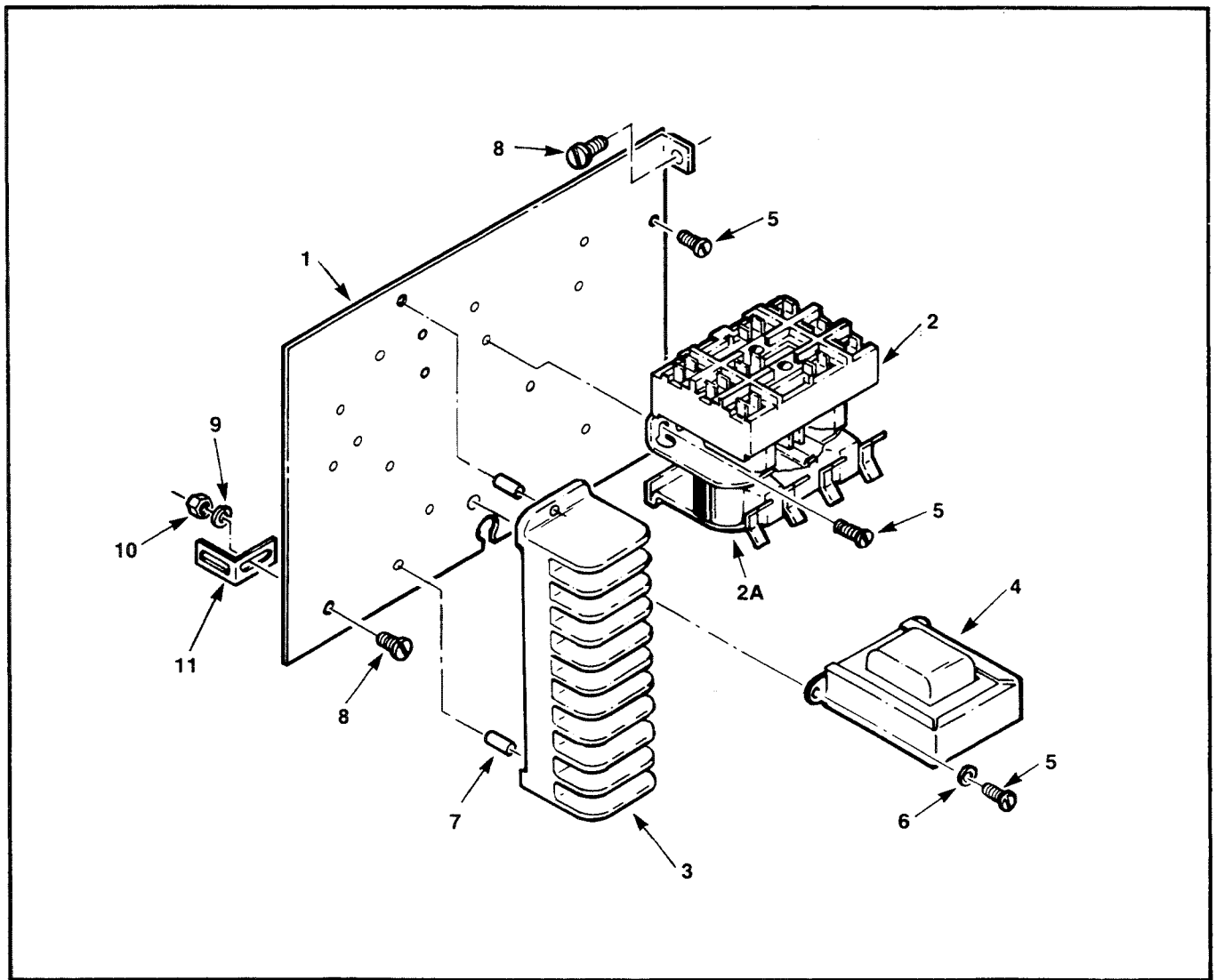

Index No.	Part Name	Part No.	Index No.	Part Name	Part No.
1	Control Panel	257J1A		Pri. 230/460, 208V, Sec. 115V, 50/60 Hz.	JF-821
2	Magnetic Reversing Switch 24V Control	820K2		Pri. 575V, Sec. 24V, 50/60 Hz	JF-821-9
	115V Control	820K317		Pri. 575V, Sec. 115V, 50/60 Hz	JF-821-2
2A	Coil (24V)	820K301			
	Coil (115V)	820K302			
2B*	Replacement Contact Kit (Includes stationary & movable contacts and springs for one magnetic reversing switch)	820K300	5	Screw	H2751
			6	Lock Washer	H-4158
			7	Eyelet	H-4972
			8	Screw	H-2981-P
3	Terminal Block	909JG-4	9	Lock Washer	H-4082-P
4	Transformer: (10 VA.) Pri. 230/460, 208V, Sec. 24V, 50/60 Hz.	JF-821-3	10	Nut (Retainer)	H-3862
			11	Retainer	285J7
			12*	Splice Connector	H-5757

*Not Illustrated

FIGURE 7-3A. CONTROLLER AREA (SINGLE SPEED HOIST)

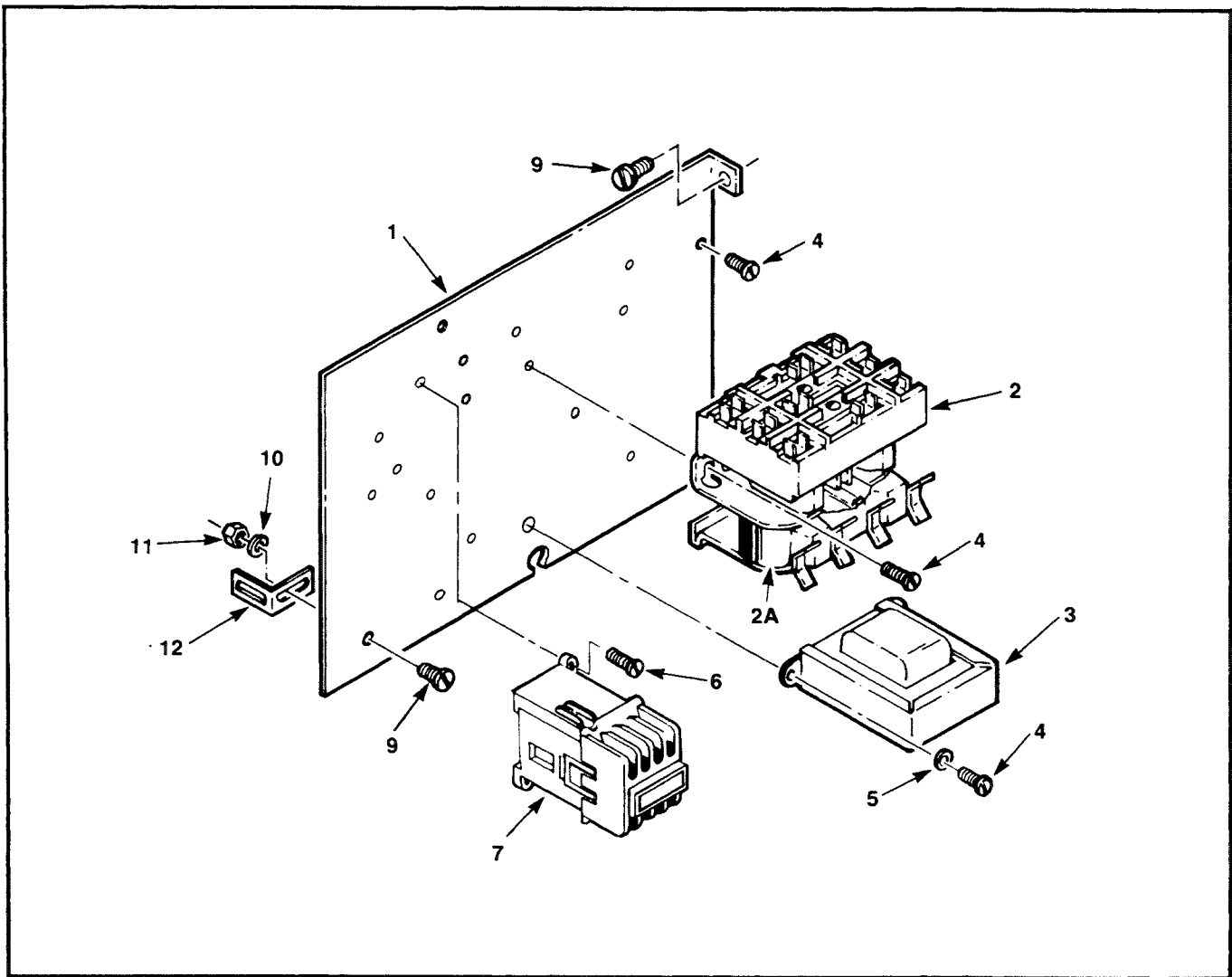

Index No.	Part Name	Part No.	Index No.	Part Name	Part No.
1	Control Panel	257J1A-1		Pri. 575V, Sec. 24V, 50/60 Hz	JF-821-16
2	Magnetic Reversing Switch 24V Control	820K2		Pri. 575V, Sec. 115V, 50/60 Hz	JF-821-20
	115V Control	820K317	4	Screw	H-2751
2A	Coil (24V)	820K301	5	Lock Washer	H-4158
	Coil (115V)	820K302	6	Screw	H-1901
2B*	Replacement Contact Kit (Includes stationary & movable contacts and springs for one magnetic reversing switch)	820K300	7	Speed Control Relay: 24V Control	820J3
				115V Control	820J4
3	Transformer: (20 VA.) Pri. 208, 230/460V, 208V, Sec. 24V, 50/60 Hz.	JF-821-15	8*	Splice Connector	H-5757
	Pri. 208, 230/460V, Sec. 115V, 50/60 Hz	JF-821-17	9	Screw	H-2981-P
			10	Lock Washer	H-4082-P
			11	Nut	H-3862
			12	Retainer	285J7

*Not Illustrated

FIGURE 7-3B. CONTROLLER AREA (TWO SPEED HOIST)

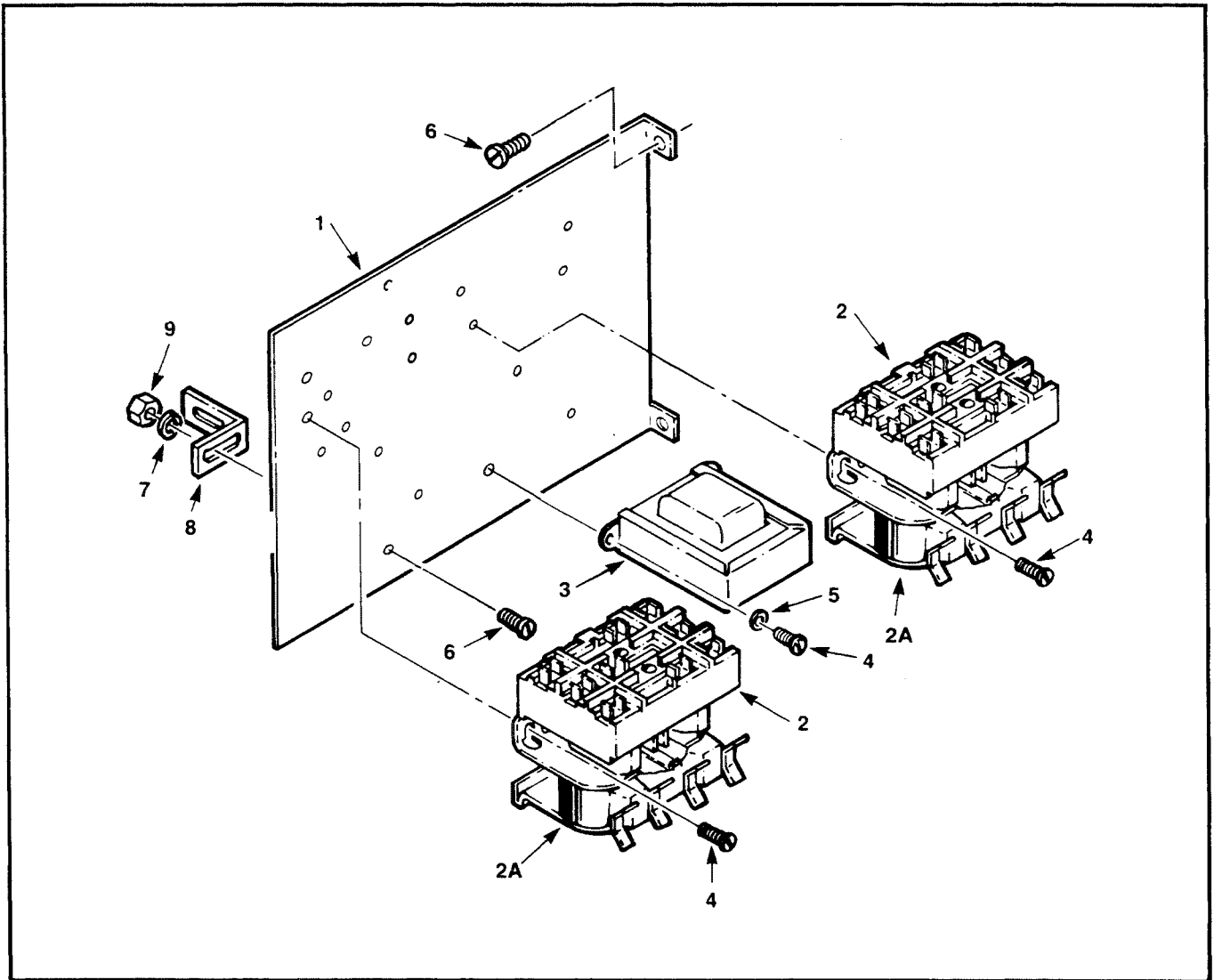

Index No.	Part Name	Part No.	Index No.	Part Name	Part No.
1	Control Panel	257J1A		Pri. 208, 230/460V, 208V, Sec. 115V, 50/60 Hz.	JF-821-17
2	Magnetic Reversing Switch 24V Control	820K2		Pri. 575V, Sec. 24V, 50/60 Hz	JF-821-16
	115V Control	820K317			
2A	Coil (24V)	820K301		Pri. 575V, Sec. 115V, 50/60 Hz	JF-821-20
	Coil (115V)	820K302			
2B*	Replacement Contact Kit (Includes stationary & movable contacts and spring for one magnetic reversing switch)	820K300	4	Screw	H2751
			5	Lock Washer	H-4158
			6	Screw	H-2981-P
			7	Lock Washer	H-4802-P
			8	Retainer	285J7
3	Transformer: (20 VA.) Pri. 208, 230/460V, 208V, Sec. 24V, 50/60 Hz.	JF-821-15	9	Nut (Retainer)	H-3862
			10*	Splice Connector	H-5757

*Not Illustrated

**FIGURE 7-3C. CONTROLLER AREA
(SINGLE SPEED HOIST, SINGLE SPEED TROLLEY)**

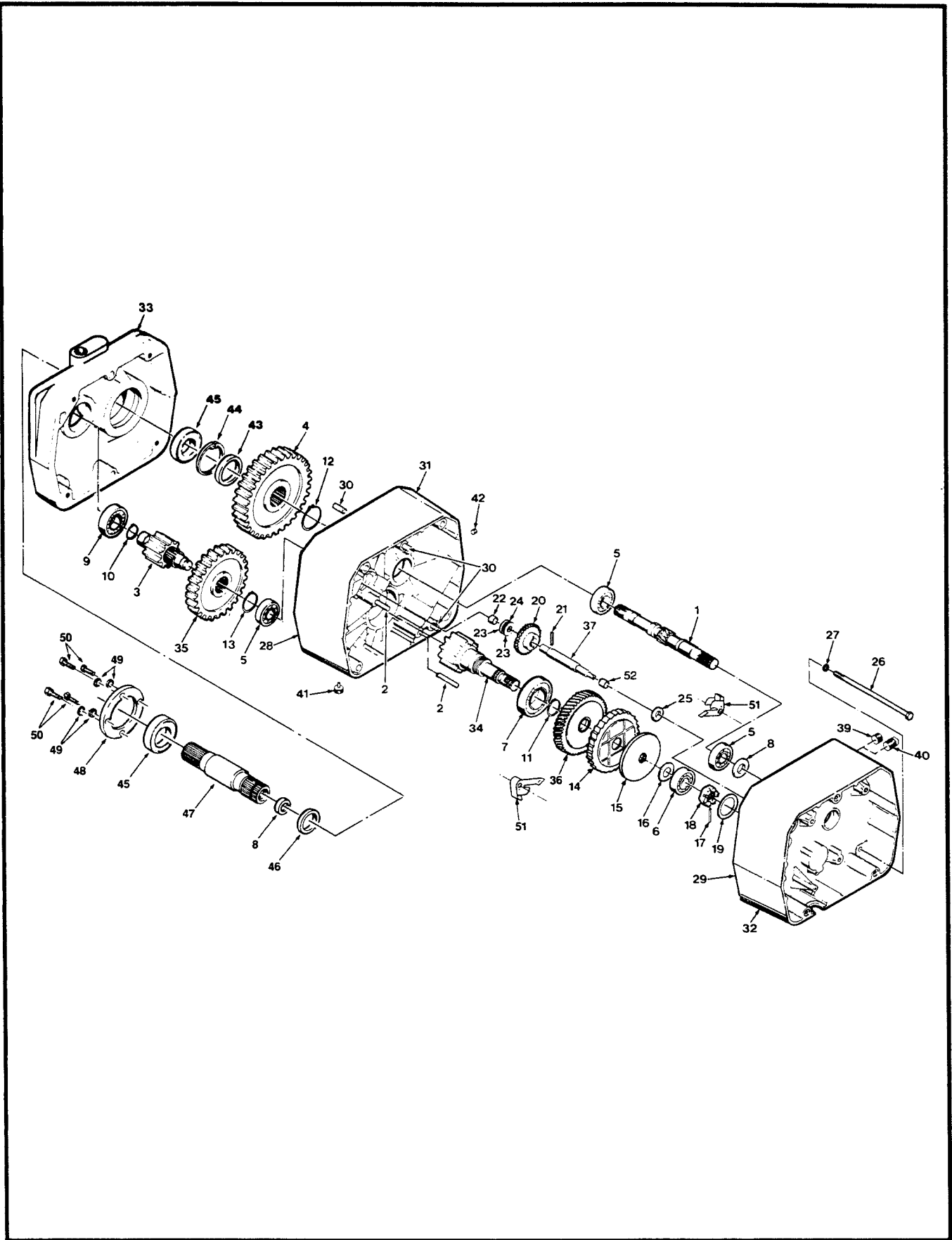
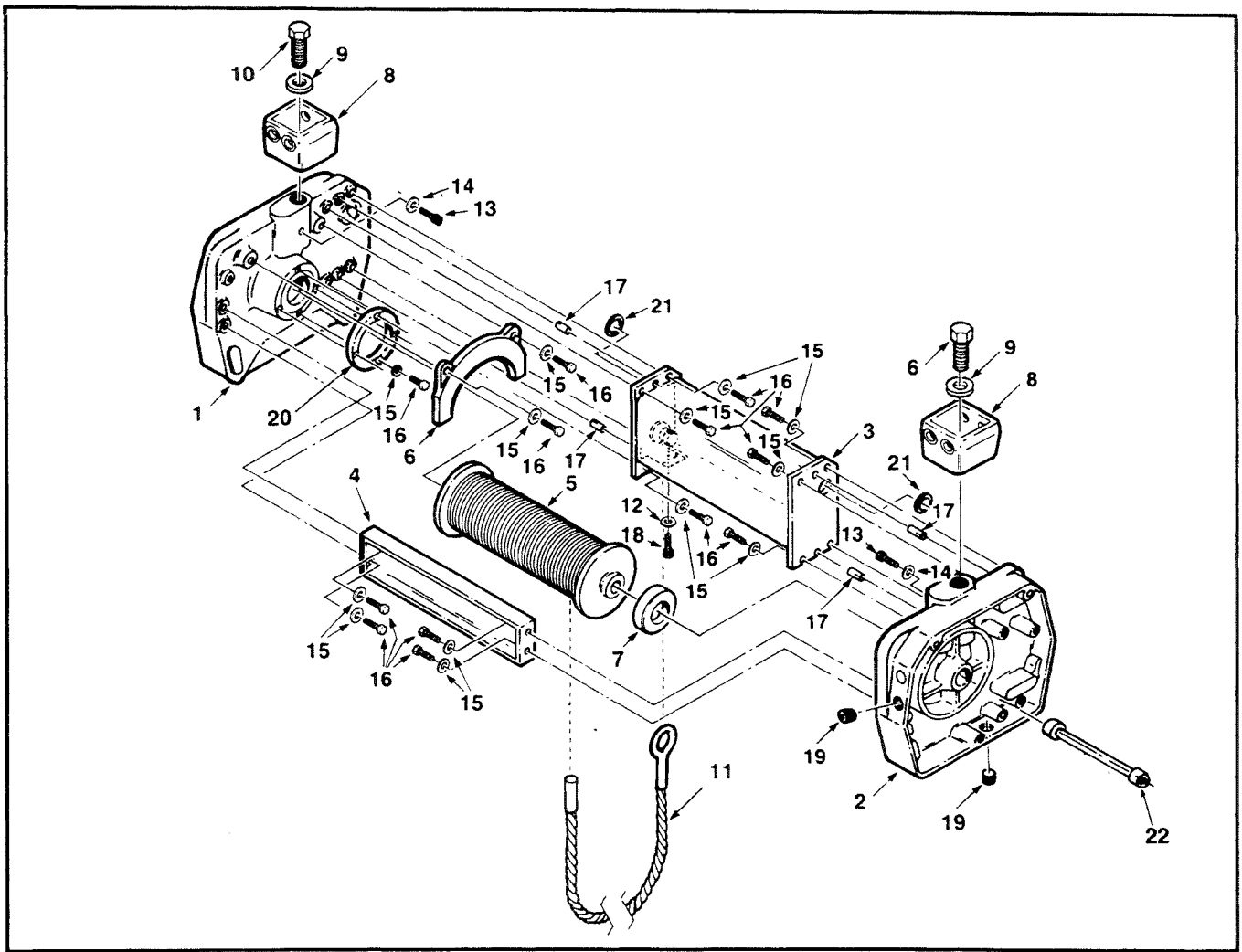

FIGURE 7-4. HOIST TRANSMISSION

Index No.	Part Name	Part No.	Index No.	Part Name	Part No.
1	High Speed Pinion	400J8	34	Intermediate Pinion:	
2	Dowel Pin	H-5493		WR-2028	402J12
3	Output Pinion	404J2		WR-4014	402J10
4	Output Gear	405K3		WR-4021	402J11
5	Bearing	500K13		WR-6010	402J11
6	Bearing	500K14		WR-6014	402J12
7	Bearing	500K15	35	Intermediate Gear:	
8	Seal	561K18		WR-2028	403J7
9	Bearing	500K16		WR-4014	403K4
10	Retaining Ring	H-5530		WR-4021	403K5
11	Retaining Ring	H-5539		WR-6010	403K5
12	Retaining Ring	H-5541		WR-6014	403J7
13	Retaining Ring	H-5540	36	Load Equalizer Assembly:	
14	Ratchet Assembly	7JG16-1		(See Paragraph 1-8)	
15	Pressure Plate	5J9		WR-2028	591JG18
16	Thrust Washer	255K11		WR-4014	591JG18
17	Drive-Lok Pin	H-5219		WR-4021	591JG19
18	Lock Nut	130J8		WR-6010	591JG28
19	Spring Washer	H-7834		WR-6014	591JG19
20	Limit Switch Gear	428J1	37	Limit Switch Drive Shaft	140J1
21	Spring Pin	H-5232	38*	Transmission Replacement	
22	Bushing	530J24		Oil Kit	14J11
23	Thrust Washer	255J19	39	Vented Plug	H-6257
24	Thrust Bearing	511J17	40	Shipping Plug	H-6272
25	Seal	561K17	41	Drain Plug	H-6268
26	Bolt	H-2333	42	Level Plug	S-25-9
27	Lock Washer	H-4157	43	Spacer (Gear)	200J10
28	Gasket, Transmission Adapter (See Fig. 7-1)	560K15	44	Retaining Ring	H-5557
29	Gasket, Transmission Cover (See Fig. 7-1)	560J6	45	Bearing	500K12
30	Dowel Pin	H-5387	46	Seal	561K26
31	Transmission Housing (See Fig. 7-1)	35J3	47	Output Shaft	132J17
32	Transmission Cover (See Fig. 7-1)	34J2	48	Bearing Retainer:	
33	Transmission Adapter:			1 & 2-Ton	250J6
	1 & 2-Ton	37J7-2	49	3-Ton	250J9
	3-Ton	37J7	50	Lock Washer	H-4066-P
			51	Screw	H-2304
			52	Pawl Ass'y	25JG4-2
				Flanged Bearing	530J29

*Not Illustrated

FIGURE 7-4. HOIST TRANSMISSION



Index No.	Part Name	Part No.	Index No.	Part Name	Part No.
1	Transmission Adapter	37J7-2	10	Suspension Stud	50J36
2	Motor Adapter	39J4-2	11	Wire Rope Assembly:	
3	Tube Assembly:			22 Ft. Lift	19J202
	22 Ft. Lift	200JG12-1		35 Ft. Lift	19J203
	35 Ft. Lift	200JG13-1		44 Ft. Lift	19J204
	44 Ft. Lift	200JG11-1		70 Ft. Lift	19J206
	70 Ft. Lift	200JG30-1	12	Lock Washer	H-4136
4	Channel Assembly:		13	Suspension Stud Locking Screw	S-49-10
	22 Ft. Lift	206JG2-1	14	Lock Washer	H-4084-P
	35 Ft. Lift	206JG3-1	15	Lock Washer	H-4063-P
	44 Ft. Lift	206JG1-1	16	Screw	S-44-47
	70 Ft. Lift	206JG7-1	17	Driv-Lok Pin	H-5230-5
5	Drum Assembly:		18	Screw (Dead End)	S-49-22
	22 Ft. Lift	16JG17-2	19	Pipe Plug	H-6276
	35 Ft. Lift	16JG17-3	20	Bearing Retainer	
	44 Ft. Lift	16JG17-1		(Reference Fig. 7-4)	250J6
	70 Ft. Lift	16JG17-7	21	Gasket	560J13
6	Drum Guard:		22	Coupling Assembly:	
	22 Ft.; 35 Ft. Lift	230J5		22 Ft. Lift	107JG8-2
	44 Ft.; 70 Ft. Lift	230J4		35 Ft. Lift	107JG8-3
7	Bearing	500K12		44 Ft. Lift	107JG8-1
8	Suspension Box	50J44A		70 Ft. Lift	107JG8-6
9	Washer	255K25			

FIGURE 7-5A. DRUM AREA (1 & 2 TON) STANDARD HEADROOM MODELS

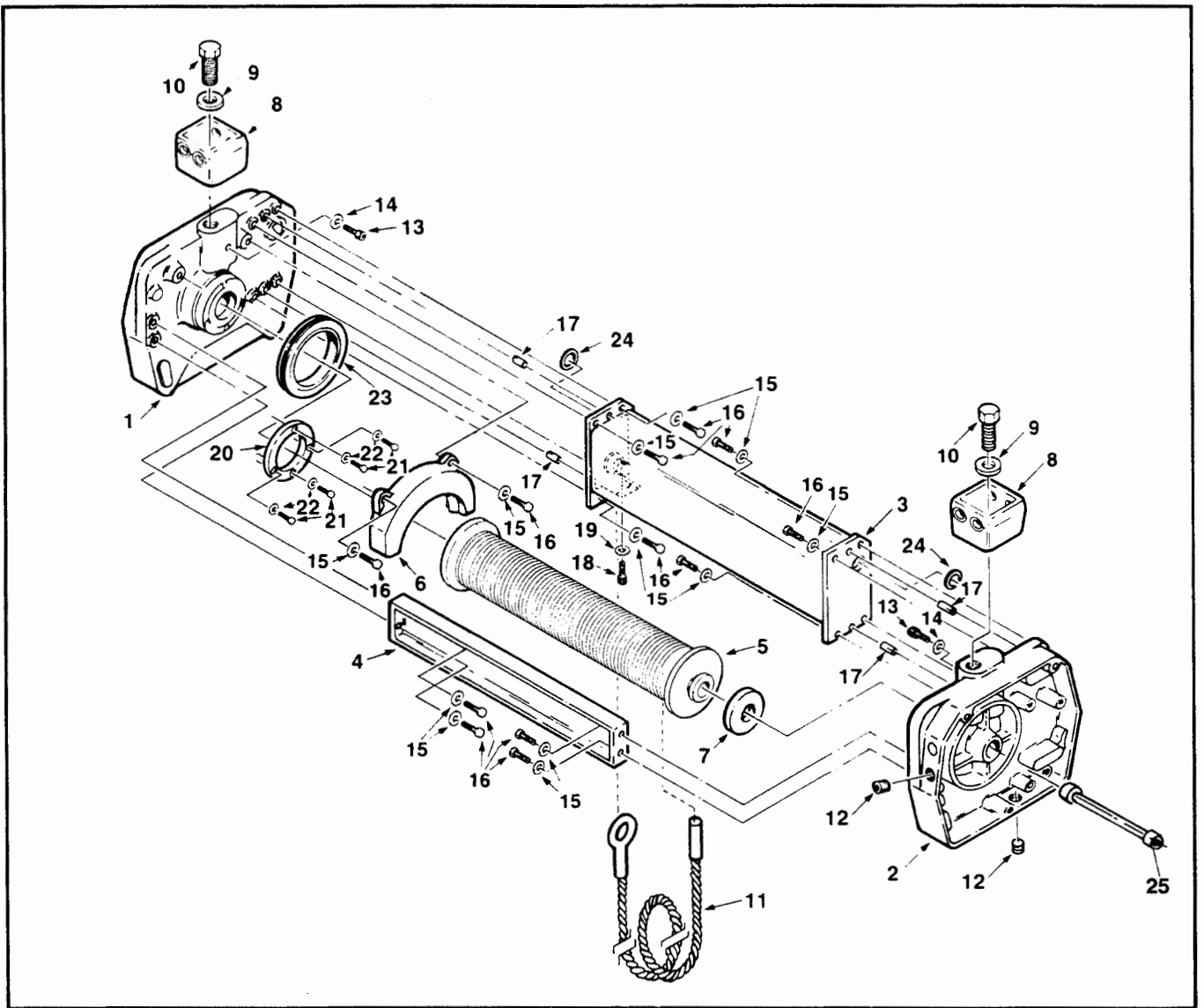

Index No.	Part Name	Part No.	Index No.	Part Name	Part No.
1	Transmission Adapter	37J7		35 Ft. Lift	19J205
2	Motor Adapter	39J4	12	Pipe Plug	H-6276
3	Tube Assembly:		13	Screw	S-49-10
	22 Ft. Lift	200JG11-1	14	Lock Washer	H-4084-P
	35 Ft. Lift	200JG30-1	15	Lock Washer	H-4063-P
4	Channel Assembly:		16	Screw	S-44-47
	22 Ft. Lift	206JG1-1	17	Driv-Lok Pin	H-5230-5
	35 Ft. Lift	206JG7-1	18	Screw	S-49-22
5	Drum Assembly:		19	Lock Washer	H-4136
	22 Ft. Lift	16JG17-1	20	Bearing Retainer	250J9
	35 Ft. Lift	16JG17-7	21	Screw	H-2304
6	Drum Guard	230J4	22	Lock Washer	H-4066-P
7	Bearing	500K12	23	Sheave Assembly	
8	Suspension Box	50J44A		(Includes Sleeve Bearing)	28JG8
9	Washer	255K25	24	Gasket	560J13
10	Suspension Stud	50J36	25	Coupling Assembly	
11	Wire Rope Assembly:			22 Ft. Lift	107JG8-1
	22 Ft. Lift	19J201		35 Ft. Lift	107JG8-6

FIGURE 7-5B. DRUM AREA (3 TON) STANDARD HEADROOM MODELS

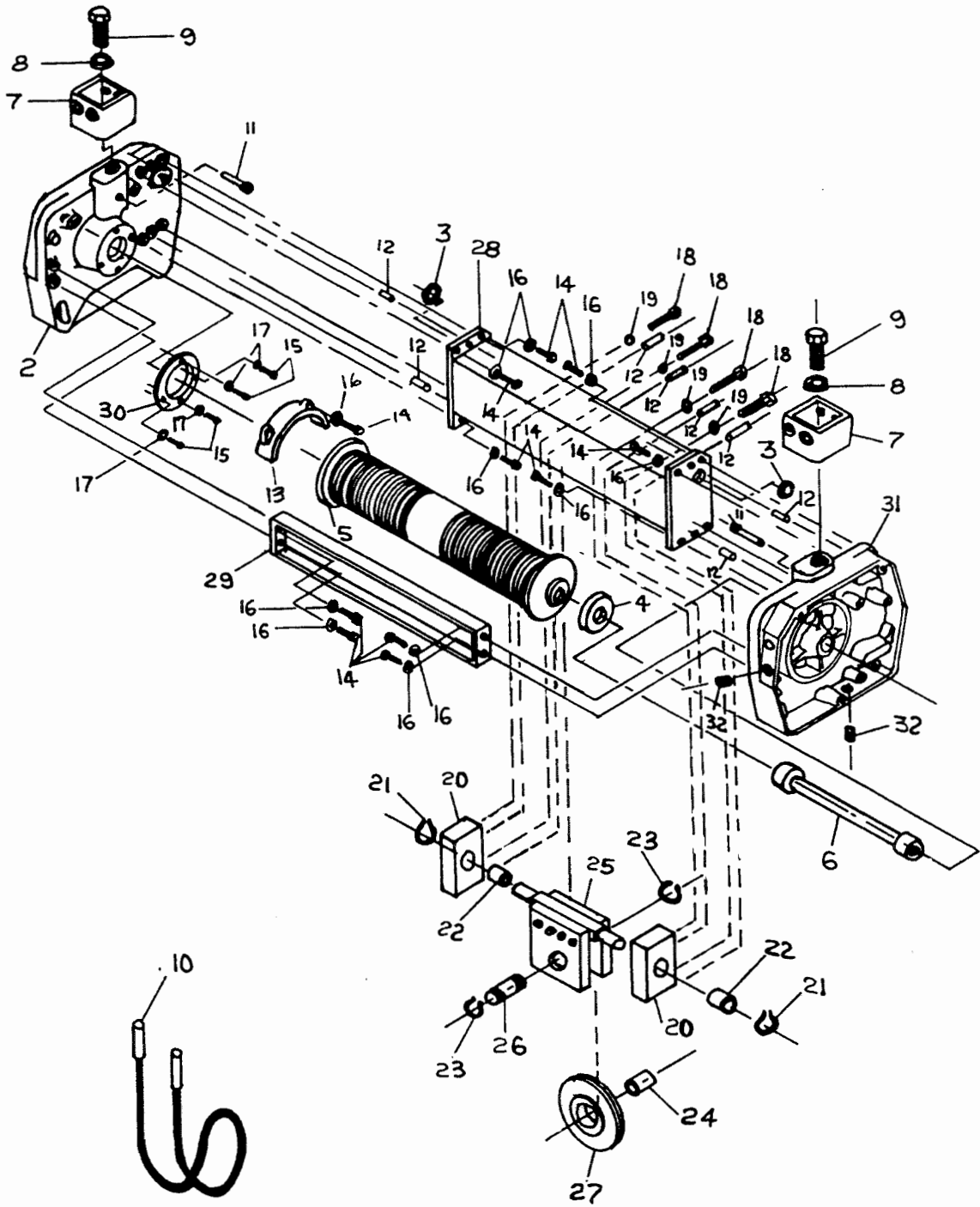

**FIGURE 7-5C. DRUM AREA
(1 & 2 TON, TRUE VERTICAL LIFT MODELS)**

Item No.	Part Name	Part No.	Item No.	Part Name	Part No.
2	Trans. Housing	37J7-1	17	Lock Washer	H-4066P
3	Gasket	560J13	18	Screw	S-49-29
4	Bearing	500K12	19	Lock Washer	H-4083P
5	Drum Ass'y		20	Pillow Block	503J7
	15 Ft. Lift	16JG17-8	21	Ret. Ring	H-5543
	25 Ft. Lift	16JG17-5	22	Bushing	530K26
	35 Ft. Lift	16JG17-6	23	Ret Ring	H-5530
6	Coupling		24	Bushing	MA-533
	15 Ft. Lift	107JG8-9	25	Equalizer	113JG1
	25 Ft. Lift	107JG8-4		Sheave	(Includes Items
	35 Ft. Lift	107JG8-8		Ass'y	#23, 24, 26, & 27)
7	Susp. Box	50J44A	26	Sheave Pin	122J21
8	Washer	255K25	27	Sheave	28J15
9	Susp. Stud	50J36	28	Tube Ass'y	
10	Cable Ass'y			15 Ft. Lift	200JG34-4
	15 Ft. Lift	19J303		25 Ft. Lift	200JG34-2
	25 Ft. Lift	19J302		35 Ft. Lift	200JG34-1
	35 Ft. Lift	19J304	29	Channel Ass'y	
11	Locking Screw	700J8		15 Ft. Lift	206JG11-1
12	Driv-Lok Pin	H-5230-5		25 Ft. Lift	206JG9-1
13	Drum Guard	230J4		35 Ft. Lift	206JG8-1
14	Screw	S44-47	30	Bearing Retainer	250J6
15	Screw	H-2304	31	Motor Adapter	39J4-2
16	Lock Washer	H-4063P	32	Pipe Plug	H-6276

**FIGURE 7-5C. DRUM AREA
(1 & 2 TON, TRUE VERTICAL LIFT MODELS)**

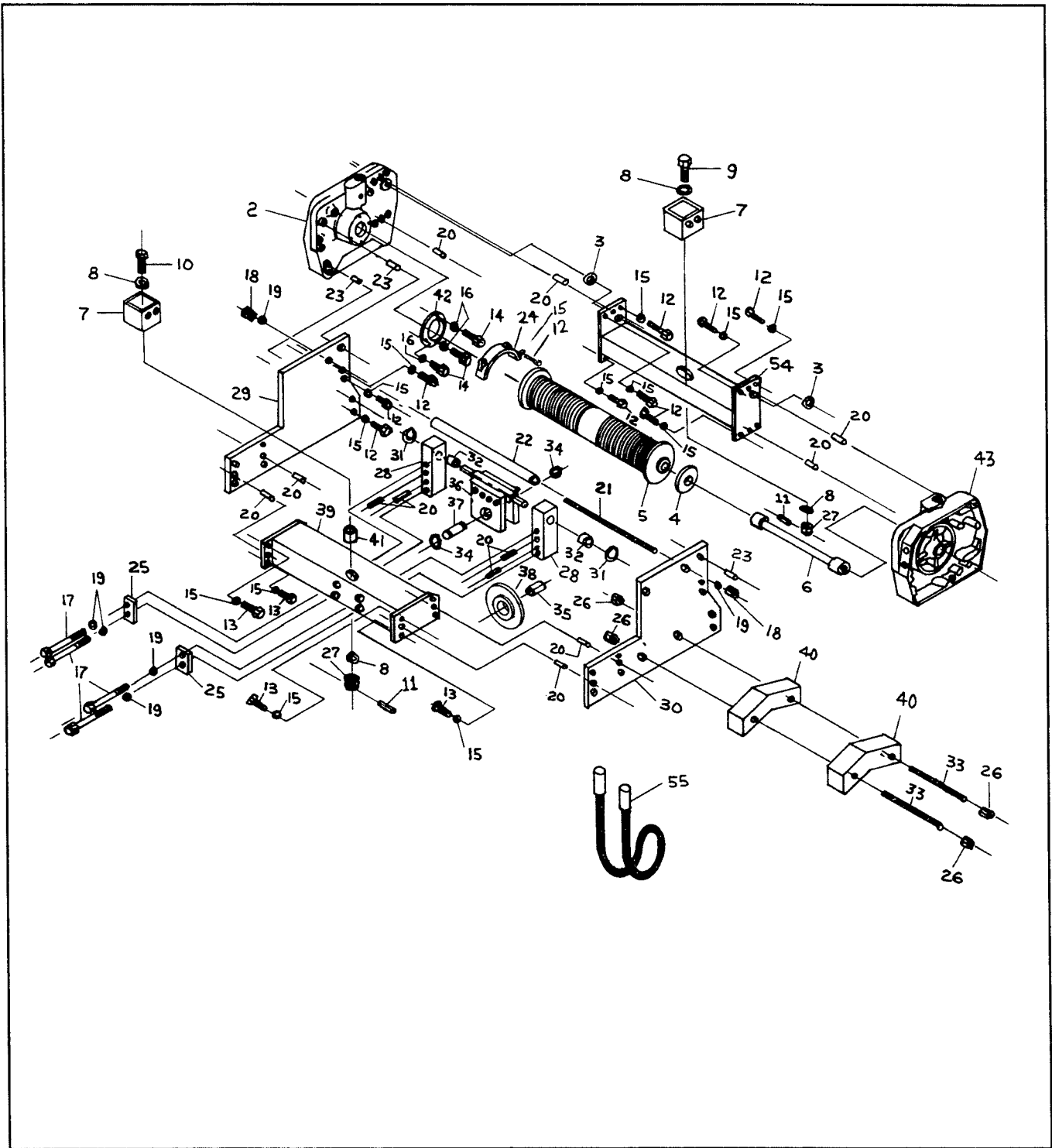

**FIGURE 7-5D. DRUM AREA
(1 & 2 TON, LOW HEADROOM MODELS)**

Item No.	Part Name	Part No.	Item No.	Part Name	Part No.
2	Trans. Housing	37J7-2	24	Drum Guard	230J4
3	Gasket	560J13	25	Backing Plate	46J16
4	Bearing	500K12	26	Nut	H-3947
5	Drum Ass'y		27	Nut	H-3928-P
	15 Ft. Lift	16JG17-8	28	Pillow Block	503J5
	25 Ft. Lift	16JG17-5	29	Side Frame	48J6
	35 Ft. Lift	16JG17-6	30	Side Frame	48J7
6	Coupling		31	Ret. Ring	H-5543
	15 Ft. Lift	107JG8-9	32	Bushing	530K26
	25 Ft. Lift	107JG8-4	33	Thr'd Rod	103J11
	35 Ft. Lift	107JG8-8	34	Ret. Ring	H-5530
7	Susp. Box	50J33	35	Bushing	MA-533
8	Washer	H4012-P	36	Equalizer	113JG1
9	King Bolt	700J7		Sheave	(Includes
10	King Bolt	700J6		Ass'y	Items #34
11	Pin	H-5221			35, 37, 38)
12	Screw	S44-47	37	Sheave Pin	122J21
13	Screw	S44-40	38	Sheave	28J15
14	Screw	H-2304	39	Tube Ass'y	
15	Lock Washer	H-4063P		15 Ft. Lift	200JG27-3
16	Lock Washer	H-4066P		25 Ft. Lift	200JG27-2
17	Bolt	H-3187		35 Ft. Lift	200JG27-1
18	Nut	H-3725P	40	Ct. Weight	52J3
19	Lock Washer	H-4083	41	Spacer	200J29
20	Pin	H-5230-P	42	Bearing Retainer	250J6
21	Tie Rod		43	Motor Adaptor	39J4-2
	15 Ft. Lift	931J1-5	54	Tube Ass'y	
	25 Ft. Lift	931J1-2		15 Ft. Lift	200JG25-3
	35 Ft. Lift	931J1-1		25 Ft. Lift	200JG25-2
22	Tie Rod Spacer			35 Ft. Lift	200JG25-1
	15 Ft. Lift	200J28-5	55	Cable Ass'y	
	25 Ft. Lift	200J28-2		15 Ft. Lift	19J303
	35 Ft. Lift	200J28-1		25 Ft. Lift	19J302
23	Pin	H5392		35 Ft. Lift	19J304

**FIGURE 7-5D. DRUM AREA
(1 & 2 TON, LOW HEADROOM MODELS)**

Index No.	Part Name	Part No.
1	Limit Switch and Shaft Assembly (Consists of Index Nos. 3 thru 12)	918JG7
4	Limit Switch Bracket Assembly (Includes Index No. 5)	JF-900-3
5	Limit Switch Bushing	JF-531-4
6	Microswitch, Limit	815J1
7	Screw	H-1402-P
8	Nut	H-3944
9	Limit Switch Shaft	JF-117-3
10	Limit Switch Shaft (Red)	JF-751-3-R
11	Limit Switch Nut (Green)	JF-751-3G
12	Retaining Ring	H-5520
13	Spring	JF-343-3
14	Screw	H-2981-P

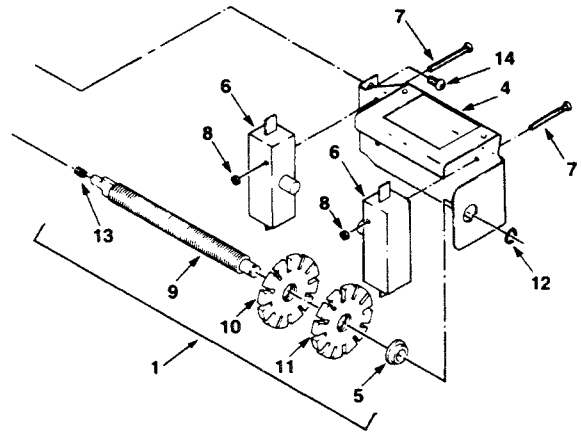
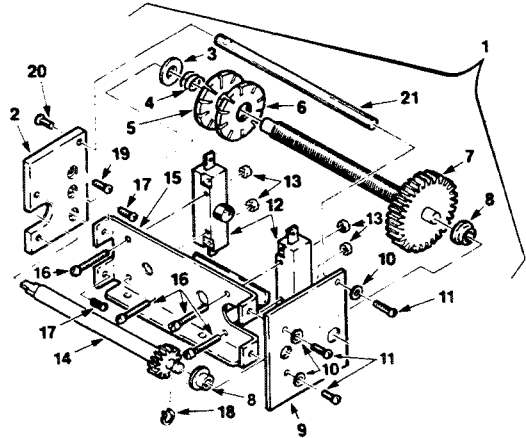
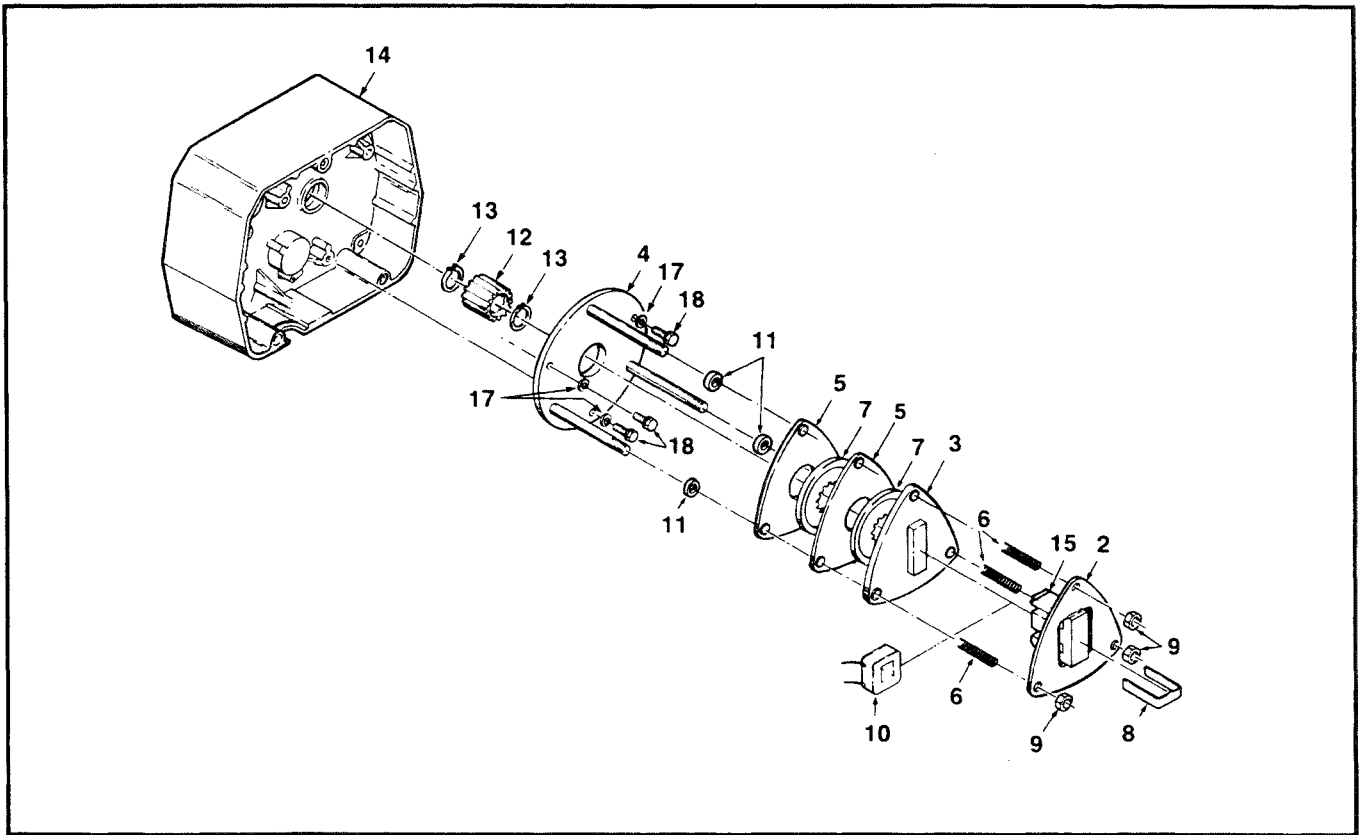

FIGURE 7-6. LIMIT SWITCH PARTS

Index No.	Part Name	Part No.
1	Long Lift Limit Switch Assembly (all items except No. 19)	944JG6WR
2	Mounting Plate	129J1
3	Thrust Washer	255K16
4	Spring	PB-287
5	Green Nut	JF-751-3G
6	Red Nut	JF-751-3R
7	Shaft and Gear Assembly	117JG2
8	Bushing	JF-531-4
9	End Plate	258J8
10	Lock Washer	H-4158
11	Screw	H-2741-P
12	Switch	815J1
13	Locknut	H-3944
14	Drive Pinion	427J1
15	Frame and Guide Assembly	258JG7
16	Screw	H-1402-P
17	Screw	854823
18	Retaining Ring	H-5520
19	Mounting Screw	H-2981-P
20	Flat Head Screw	H-1210
21	Post	110J14



**FIGURE 7-6A.
LONG LIFT LIMIT SWITCH
1 & 2 TON W/70 FT. LIFT AND 3 TON W/35 FT. LIFT ONLY**



Index No.	Part Name	Part No.	Index No.	Part Name	Part No.
1	Disc Brake Assembly: (Single Speed) 230/460V, 3-PH, 60 Hz 575V, 3-PH, 60 Hz 208V, 3-PH, 60 Hz (Two Speed) 230V, 3-PH, 60 Hz 460V, 3-PH, 60 Hz 575V, 3-PH, 60 Hz 208V, 3-PH, 60 Hz (Consists of Items 2 thru 11)	854JG24 854JG26 854JG27 854JG24 854JG25 854JG26 854JG27	10	Coil: 230V, 60 Hz (For Brake 854JG24) 460V, 60 Hz (For Brake 854JG25) 575V, 60 Hz (For Brake 854JG26) 208V, 60 Hz (For Brake 854JG27)	JF-853-2 JF-853-3 JF-853-4 JF-853-5
2	Plate and Frame Assembly	29IJG8	11	Spacer	200J15
3	Plate and Armature Assembly	29IJG9	12	Brake Adapter	142J2
4	Plate and Stud Assembly	290JG4	13	Retaining Ring	H-5527
5	Brake Plate	29IJ10	14	Transmission Cover (See Fig. 7-1)	34J2
6	Spring	344J4	15**	Shading Coil Element (Must be attached to frame with H-7812 adhesive)	860J1
7	Brake Disc Assembly	581JG2	16*	Adhesive (1 oz. Tube)	H-7812
8	Retainer	JF-710	17	Lock Washer	H-4063-P
9	Lock Nut	H-3949	18	Screw	H-2988-P

*Not Illustrated

**Replacement requires use of adhesive

**FIGURE 7-7A. MOTOR BRAKE PARTS
(2 HP) MODELS**

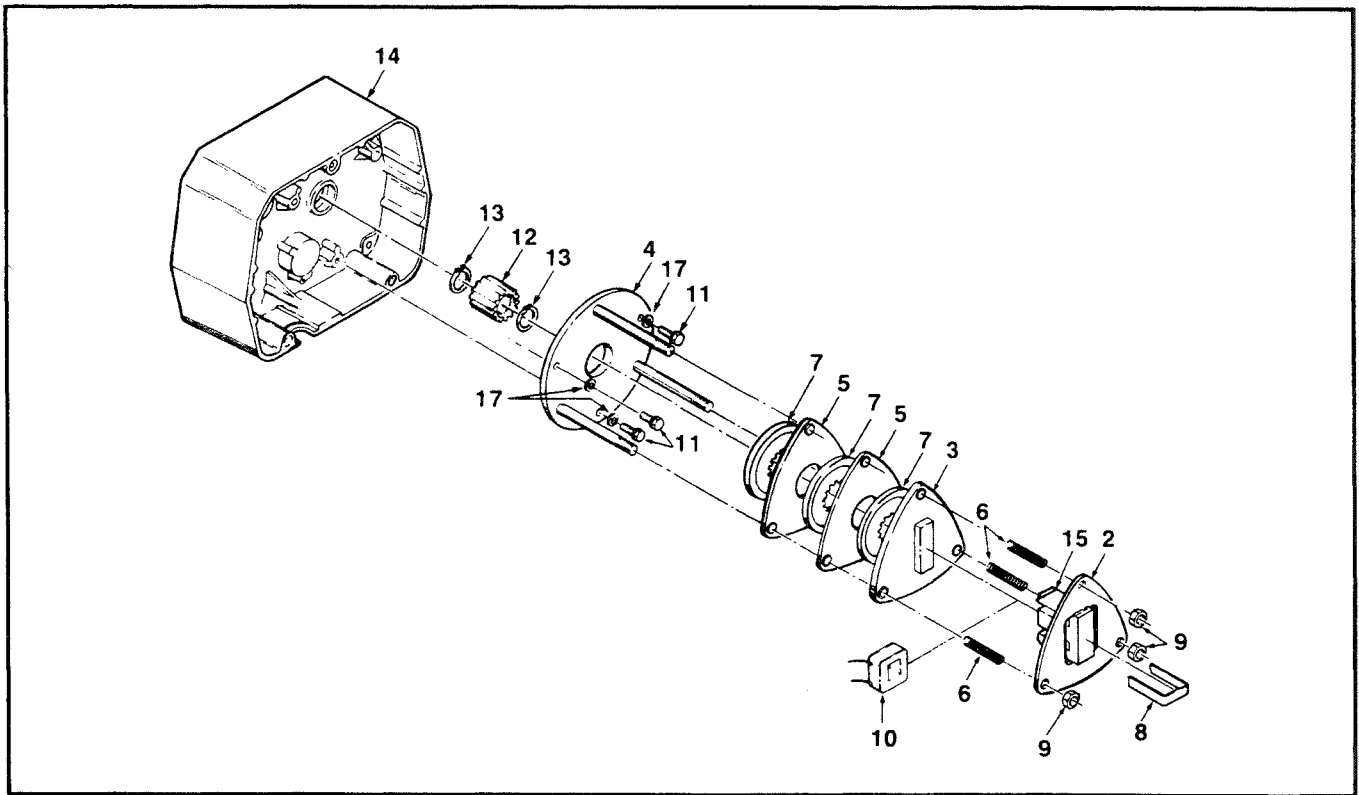

Index No.	Part Name	Part No.	Index No.	Part Name	Part No.
1	Disc Brake Assembly: (Single Speed) 230/460V, 60 Hz, 3-PH 575V, 60 Hz, 3-PH 208V, 60 Hz, 3-PH (Two Speed) 230V, 60 Hz, 3-PH 460V, 60 Hz, 3-PH 575V, 60 Hz, 3-PH 208V, 60 Hz, 3-PH (Consists of Items 2 thru 10)	854JG20 854JG22 854JG23 854JG20 854JG21 854JG22 854JG23	10	Coil: 230V, 60 Hz (For Brake 854JG20) 460V, 60 Hz (For Brake 854JG21) 575V, 60 Hz (For Brake 854JG22) 208V, 60 Hz (For Brake 854JG23)	JF-853-2 JF-853-3 JF-853-4 JF-853-5
2	Plate and Frame Assembly	29IJG8	11	Screw	H-2988-P
3	Plate and Armature Assembly	29IJG9	12	Brake Adapter	142J2
4	Plate and Stud Assembly	290JG4	13	Retaining Ring	H-5527
5	Brake Plate	29IJ10	14	Transmission Cover	34J2
6	Spring	344J4	15**	Shading Coil Element (Must be attached to frame with H-7812 adhesive)	860J1
7	Brake Disc Assembly	581JG2	16*	Adhesive (1 oz. Tube)	H-7812
8	Retainer	JF-710	17	Lock Washer	H-4063-P
9	Lock Nut	H-3949			

*Not Illustrated

**Replacement requires use of adhesive

**FIGURE 7-7B. MOTOR BRAKE PARTS
(3 HP) MODELS**

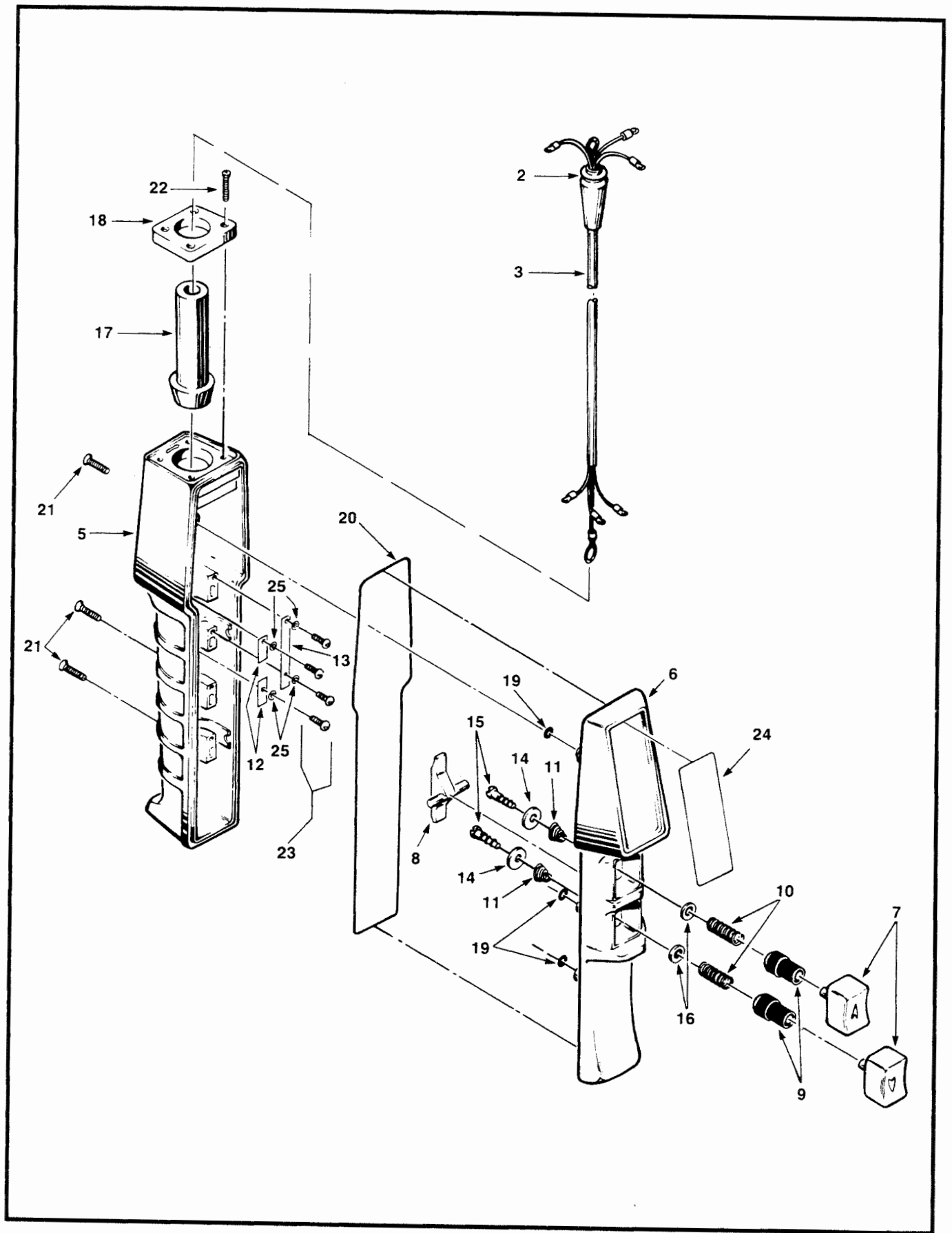

FIGURE 7-8A. PUSHBUTTON
(SINGLE SPEED HOISTS)

Index No.	Part Name	Part No.
1	Pushbutton and Cable Assembly: (Consists of Index Nos. 2 thru 25)	
	PB Drop	
	11 Ft.	PB-299-11B
	18 Ft.	PB-299-16B
	21 Ft.	PB-299-21B
	26 Ft.	PBS-299-26B
	31 Ft.	PB-299-31B
	40 Ft.	PBS-299-40B
	66 Ft.	PBS-299-66B
	Special PB Drop	PBS-299-*B
2	Rubber Grommet	JF-761
3	Pushbutton Cable Assembly:	
	PB Drop In Feet:	
	11 Ft.	PB-299-11
	18 Ft.	PB-299-18
	21 Ft.	PB-299-21
	26 Ft.	PBS-299-26
	31 Ft.	PB-299-31
	40 Ft.	PBS-299-40
	66 Ft.	PBS-299-66
	Special PB Drop	PBS-299-*
4	Pushbutton Assembly: (Consists of Index Nos. 5 thru 25)	534K97-B
5	Enclosure	PB-282-4
6	Cover	PB-298
7	Pushbutton	PB-284-2
8	Interlock	PB-285
9	Boot	PB-286
10	Spring, Compression	PB-287
11	Spring, Conical	PB-288
12	Contact Plate	PB-289
13	Contact Plate, Common	PB-290
14	Washer, Contact	PB-291
15	Screw	PB-301
16	Washer, Boot	PB-293
17	Grommet	PB-294-1
18	Cap, Enclosure	PB-295
19	"O" Ring	X-6477-1
20	Rubber Seal	H-7851
21	Screw	H-2991
22	Screw	H-2992
23	Screw	H-2993
24	Warning Tag	PB-296
25	Lock Washer	H-4160

(*Equal to P.B. Drop)

**FIGURE 7-8A. PUSHBUTTON
(SINGLE SPEED HOISTS)**

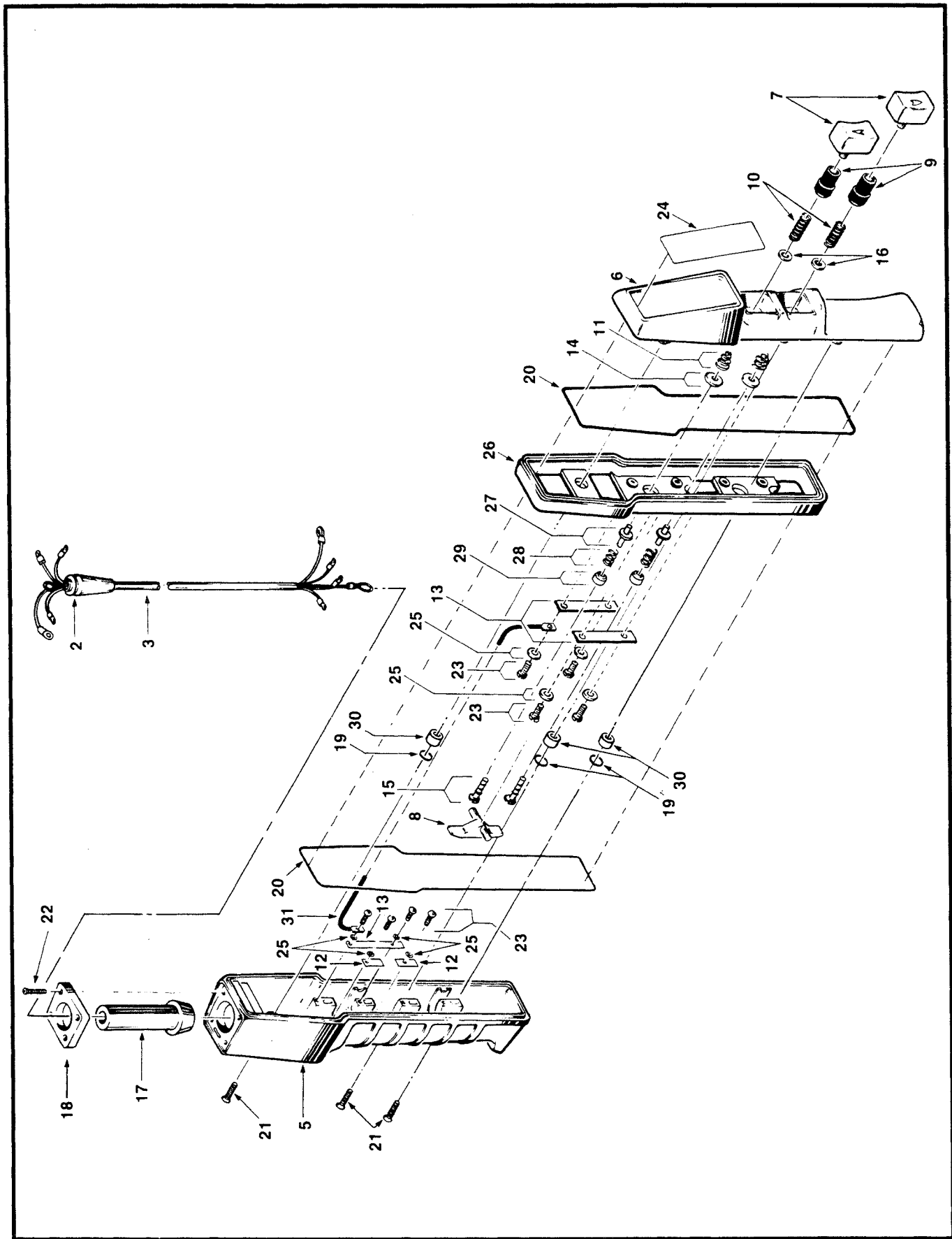
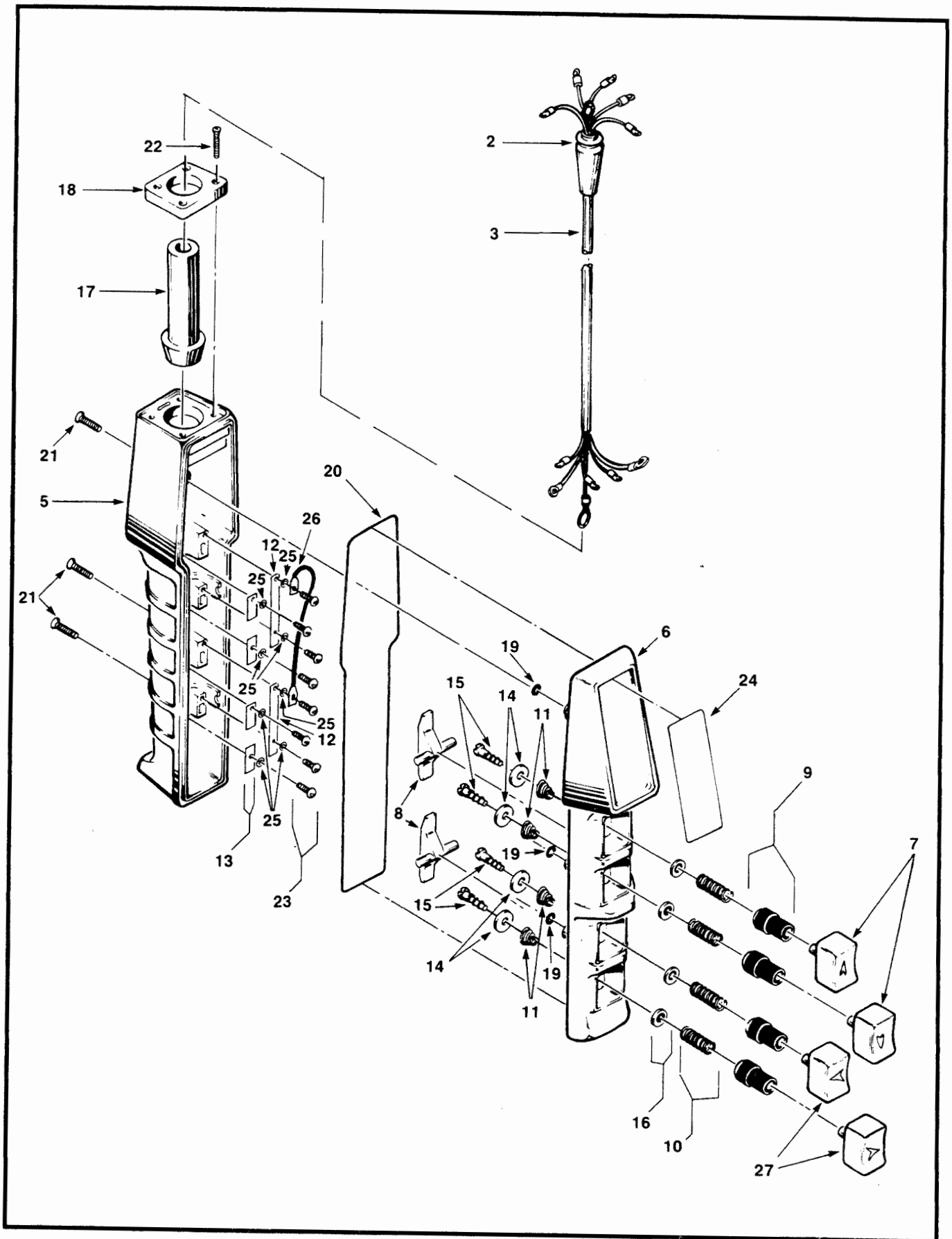

FIGURE 7-8B. PUSHBUTTON
(TWO SPEED HOISTS)

Index No.	Part Name	Part No.
1	Pushbutton and Cable Assembly: (Consists of Index Nos. 2 thru 31) PB Drop In Feet:	
	11 Ft.	534JG4-11
	18 Ft.	534JG4-18
	21 Ft.	534JG4-21
	26 Ft.	534JG4-26
	31 Ft.	534JG4-31
	40 Ft.	534JG4-40
	66 Ft.	534JG4-66
	Special PB Drop	534JG4-*
2	Rubber Grommet	JF-761
3	Pushbutton Cable Assembly: PB Drop In Feet:	
	11 Ft.	PB-300-11
	18 Ft.	PB-300-18
	21 Ft.	PB-300-21
	26 Ft.	PBS-300-26
	31 Ft.	PB-300-31
	40 Ft.	PBS-300-40
	66 Ft.	PBS-300-66
	Special PB Drop	PBS-300-*
4	Pushbutton Assembly: (Consists of Index Nos. 5 thru 31)	534JG4
5	Enclosure	PB-282-4
6	Cover	PB-298
7	Pushbutton	PB-284-22
8	Interlock	PB-285-1
9	Boot	PB-286
10	Spring, Compression	PB-287
11	Spring, Conical	PB-288
12	Contact Plate	PB-289
13	Contact Plate, Common	PB-290
14	Washer, Contact	PB-291
15	Screw	H-1852-P
16	Washer, Boot	PB-293
17	Grommet	PB-294-1
18	Cap, Enclosure	PB-295
19	"O" Ring	X-6477-1
20	Rubber Seal	H-7851
21	Screw (Enclosure)	H-2925
22	Screw (Cap)	H-2992
23	Screw (Plates)	H-2993
24	Warning Tag	PB-296
25	Lock Washer	H-4160
26	2-Speed Adapter	PB-308
27	Insulating Bushing	755J1
28	Spring, Lower	344J5
29	Contact Button	201J1
30	Bushing	200J16
31	Jumper Wire	JF-940-42

(*Equal to P.B. Drop)

FIGURE 7-8B. PUSHBUTTON (TWO SPEED HOISTS)

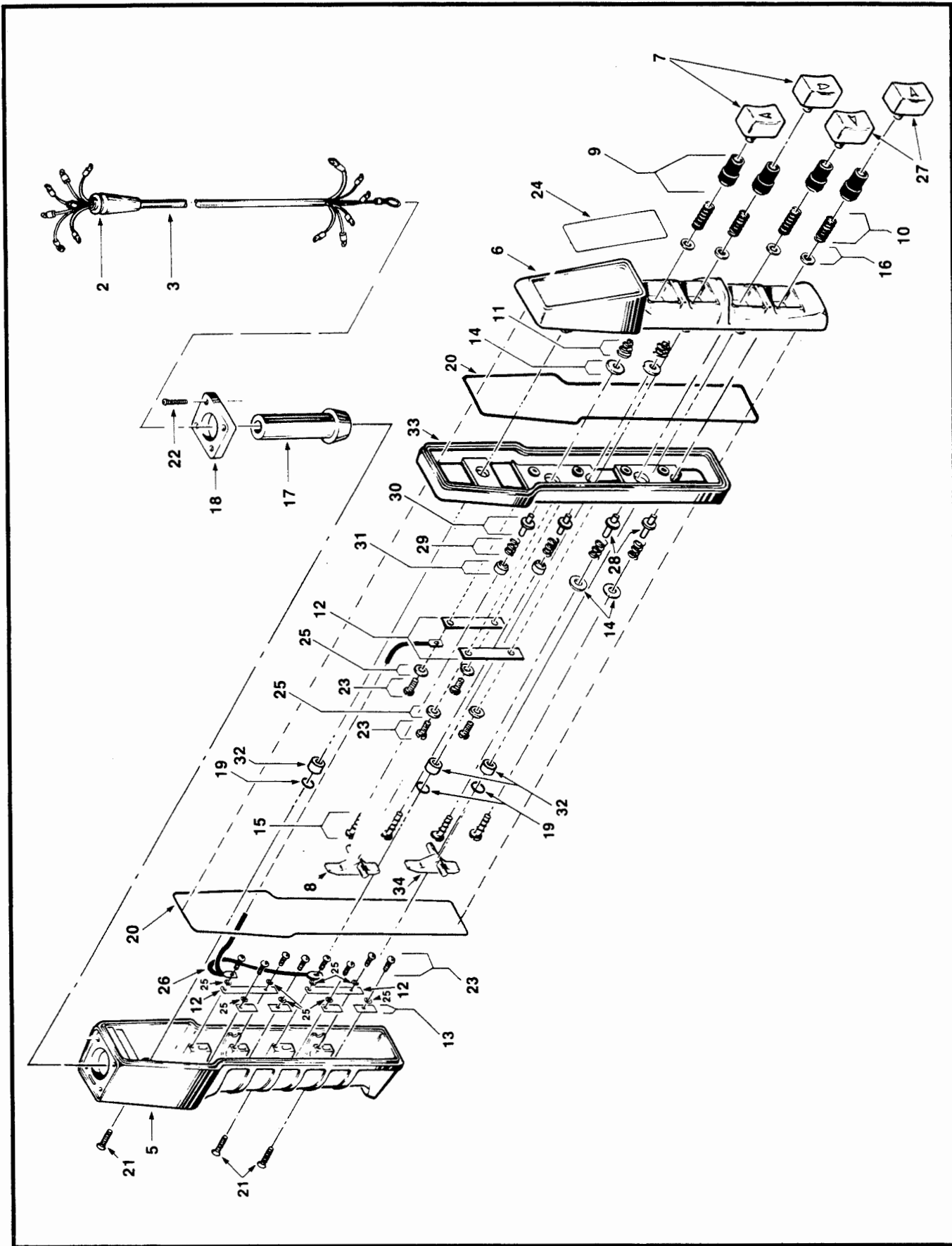

**FIGURE 7-8C. PUSHBUTTON
(SINGLE SPEED HOIST - SINGLE SPEED TROLLEY)**

Index No.	Part Name	Part No.
1	Pushbutton and Cable Assembly: (Consists of Index Nos. 2 thru 27) PB Drop In Feet: 11 Ft. 18 Ft. 21 Ft. 26 Ft. 31 Ft. 40 Ft. 66 Ft. Special PB Drop	PB-300-11A PB-300-18A PB-300-21A PBS-300-26A PB-300-31A PBS-300-40A PBS-300-66A PBS-300-*A
2	Rubber Grommet	JF-761
3	Pushbutton Cable Assembly: PB Drop In Feet: 11 Ft. 18 Ft. 21 Ft. 26 Ft. 31 Ft. 40 Ft. 66 Ft. Special PB Drop	PB-300-11 PB-300-18 PB-300-21 PBS-300-26 PB-300-31 PBS-300-40 PBS-300-66 PBS-300-*
4	Pushbutton Assembly: (Consists of Index Nos. 5 thru 27)	534K98
5	Enclosure	PB-282-4
6	Cover	PB-283
7	Pushbutton (Hoist)	PB-284-2
8	Interlock	PB-285
9	Boot	PB-286
10	Spring, Compression	PB-287
11	Spring, Conical	PB-288
12	Contact Plate, Common	PB-290
13	Contact Plate	PB-289
14	Washer, Contact	PB-291
15	Screw	PB-301
16	Washer, Boot	PB-293
17	Grommet	PB-294-2
18	Cap, Enclosure	PB-295
19	"O" Ring	X-6477-1
20	Seal	H-7851
21	Screw	H-2991
22	Screw	H-2992
23	Screw	H-2993
24	Warning Tag	PB-296
25	Lock Washer	H-4160
26	Jumper (Common)	JF-940-42
27	Pushbutton (Trolley)	PB-284-1

(*Equal to P.B. Drop)

**FIGURE 7-8C. PUSHBUTTON
(SINGLE SPEED HOIST - SINGLE SPEED TROLLEY)**



**FIGURE 7-8D. PUSHBUTTON
 (TWO SPEED HOIST, SINGLE SPEED TROLLEY;
 SINGLE SPEED HOIST, TWO SPEED TROLLEY)**

Index No.	Part Name	Part No.	Index No.	Part Name	Part No.
1	Pushbutton and Cable Assembly: (Consists of Index Nos. 2 thru 34) Two Speed Hoist, Single Speed Trolley PB Drop In Feet: 11 Ft. 18 Ft. 21 Ft. 26 Ft. 31 Ft. 40 Ft. 66 Ft. Special PB Drop Single Speed Hoist, Two Speed Trolley PB Drop In Feet: 11 Ft. 18 Ft. 21 Ft. 26 Ft. 31 Ft. 40 Ft. 66 Ft. Special PB Drop	534JG5-11 534JG5-18 534JG5-21 534JG5-26 534JG5-31 534JG5-40 534JG5-66 534JG5-*	4	Pushbutton Assembly: (Consists of Index Nos. 5 thru 34) Two Speed Hoist, Single Speed Trolley Single Speed Hoist, Two Speed Trolley Enclosure Cover Pushbutton (Hoist) Interlock (Black) Boot Spring, Compression Spring, Conical Contact Plate, Common Contact Plate Washer, Contact Screw Washer, Boot Grommet Cap, Enclosure "O" Ring Seal Screw Screw Screw Warning Tag Lock Washer Jumper Pushbutton (Trolley) Spacer Spring, Lower Insulating Bushing Lower Contact Bushing Two-Speed Adapter Interlock (Red)	534JG5 534JG6 PB-282-4 PB-283 PB-284-22 PB-285-1 PB-286 PB-287 PB-288 PB-290 PB-289 PB-291 H-1852-P PB-293 PB-294-2 PB-295 X-6477-1 H-7851 H-2925 H-2992 H-2993 PB-296 H-4160 JF-940-III PB-284-21 755J2 344J5 755J1 201J1 200J16 PB-308 PB-285
2	Rubber Grommet	JF-761-1	23	Screw	H-2992
3	Pushbutton Cable Assembly: PB Drop In Feet: 11 Ft. 18 Ft. 21 Ft. 26 Ft. 31 Ft. 40 Ft. 66 Ft. Special PB Drop	PB-309-11 PBS-309-18 PBS-309-21 PBS-309-26 PB-309-31 PBS-309-40 PBS-309-66 PBS-309-*	24 25 26 27 28 29 30 31 32 33 34		

(*Equal to P.B. Drop)

**FIGURE 7-8D. PUSHBUTTON
(TWO SPEED HOIST, SINGLE SPEED TROLLEY;
SINGLE SPEED HOIST, TWO SPEED TROLLEY)**

Index No.	Part Name	Part No.	Index No.	Part Name	Part No.
1	Pushbutton and Cable Assembly: (Consists of Index Nos. 2 thru 33)		7	Pushbutton (Hoist)	PB-284-22
	PB Drop In Feet:		8	Interlock	PB-285-1
	11 Ft.	534JG7-11	9	Boot	PB-286
	18 Ft.	534JG7-18	10	Spring, Compression	PB-287
	21 Ft.	534JG7-21	11	Spring, Conical	PB-288
	26 Ft.	534JG7-26	12	Contact Plate, Common	PB-290
	31 Ft.	534JG7-31	13	Contact Plate	PB-289
	40 Ft.	534JG7-40	14	Washer, Contact	PB-291
	66 Ft.	534JG7-66	15	Screw	H-1852-P
	Special PB Drop	534JG7-*	16	Washer, Boot	PB-293
2	Rubber Grommet	JF-761-1	17	Grommet	PB-294-2
3	Pushbutton Cable Assembly:		18	Cap, Enclosure	PB-295
	PB Drop In Feet:		19	"O" Ring	X-6477-1
	11 Ft.	PB-309-11	20	Seal	H-7851
	18 Ft.	PBS-309-18	21	Screw	H-2925
	21 Ft.	PBS-309-21	22	Screw	H-2992
	26 Ft.	PBS-309-26	23	Screw	H-2993
	31 Ft.	PB-309-31	24	Warning Tag	PB-296
	40 Ft.	PBS-309-40	25	Lock Washer	H-4160
	66 Ft.	PBS-309-66	26	Jumper	JF-940-111
	Special PB Drop	PBS-309-*	27	Pushbutton (Trolley)	PB-284-21
4	Pushbutton Assembly: (Consists of Index Nos. 5 thru 33)		28	Jumper (Two-Speed Common)	JF-940-42
		534JG7	29	Insulating Bushing	755J1
5	Enclosure	PB-282-4	30	Spring, Lower	344J5
6	Cover	PB-283	31	Lower, Contact	201J1
			32	Bushing	200J16
			33	2-Speed Adapter	PB-308

(*Equal to P.B. Drop)

**FIGURE 7-8E. PUSHBUTTON
(TWO SPEED HOIST, TWO SPEED TROLLEY)**

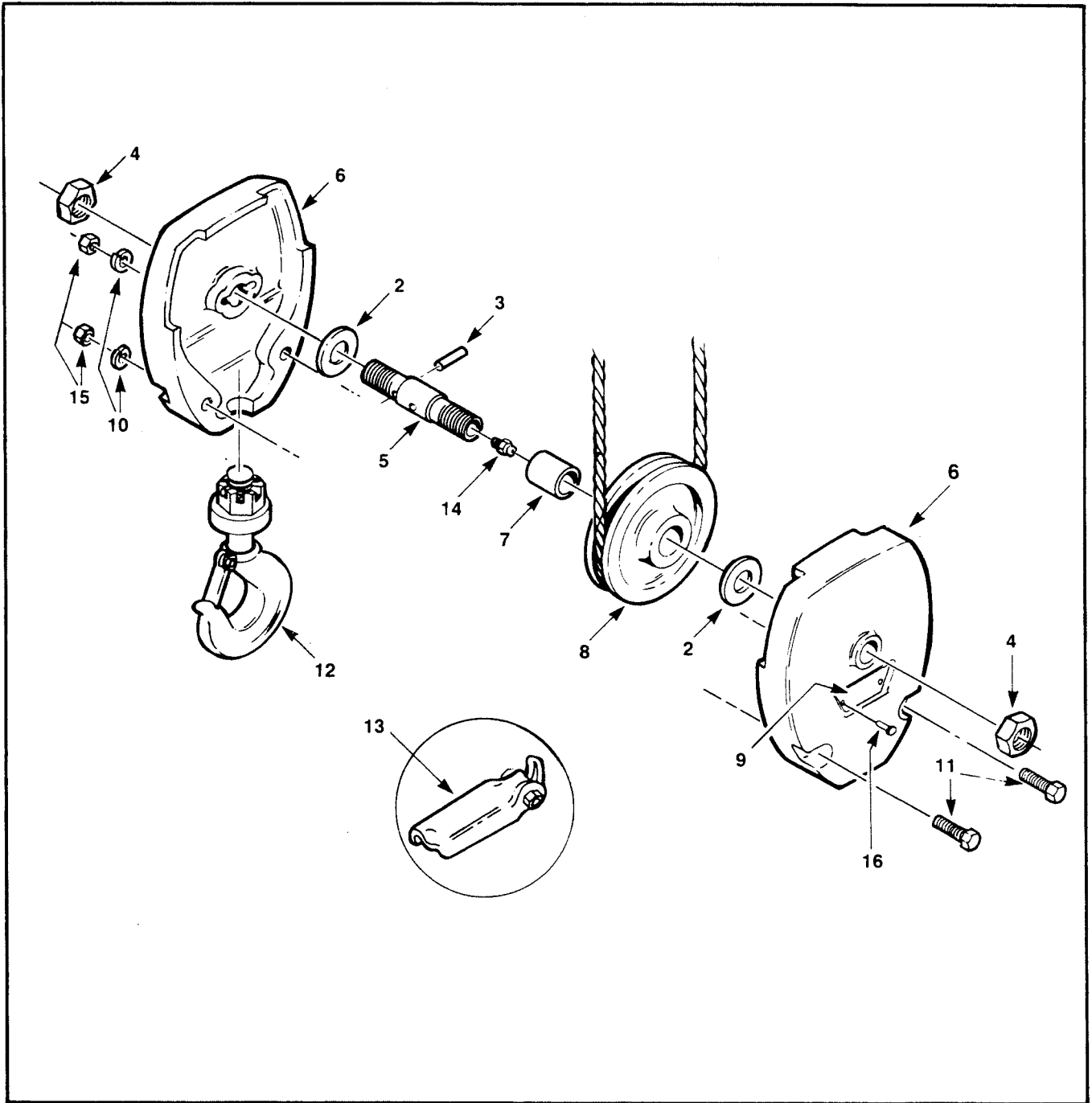

Index No.	Part Name	Part No.	Index No.	Part Name	Part No.
1	Bottom Block Assembly (Capacity Plate and Drive Rivet Not Included)	914JG17	9	Capacity Plate 1 Ton 2 Ton	675K28 675K30
2	Washer	CB-252-2	10	Lock Washer	H-4063-P
3	Driv-Lok Pin	H-5211	11	Screw	S44-45
4	Lock Nut	H-3940	12	Hook Assembly with Latch	3JG14S
5	Sheave Pin	122J9	13	Latch Kit	H-7544
6	Side Plate	30J18	14	Grease Fitting	H-7818
7	Bushing	F-1-A	15	Nut	H-3563
8	Sheave	28J9	16	Drive Rivet	H-2861-P

**FIGURE 7-9A. BOTTOM BLOCK (1 & 2 TON)
STANDARD HEADROOM MODELS**

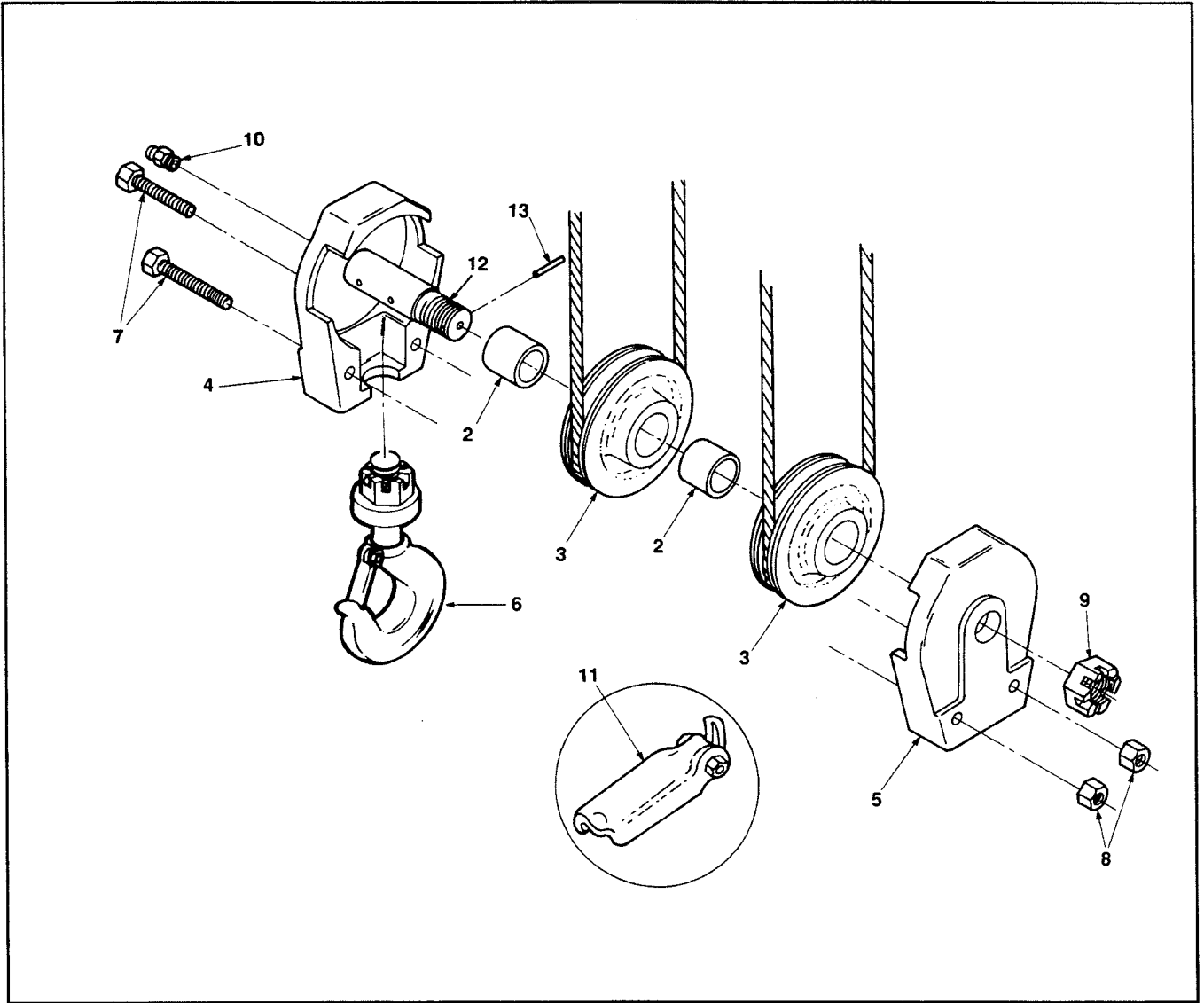

Index No.	Part Name	Page No.
1	Bottom Block Ass'y (Consists of Index Nos. 2-13)	914JG22
2	Bushing	530K10
3	Sheave	28J13
4	Bottom Block Half (Grease Fitting Side)	30J22
5	Bottom Block Half (Nut Side)	30J22-1
6	Hook Assembly	3JG8S
7	Screw	H-2431
8	Lock Nut	H-3966P
9	Slotted Nut	H-3925P
10	Grease Fitting	SK974-32
11	Latch Kit	H-7545
12	Sheave Pin	122J17
13	Roll Pin	H-5256

**FIGURE 7-9B BOTTOM BLOCK (3-TON)
STANDARD HEADROOM MODELS**

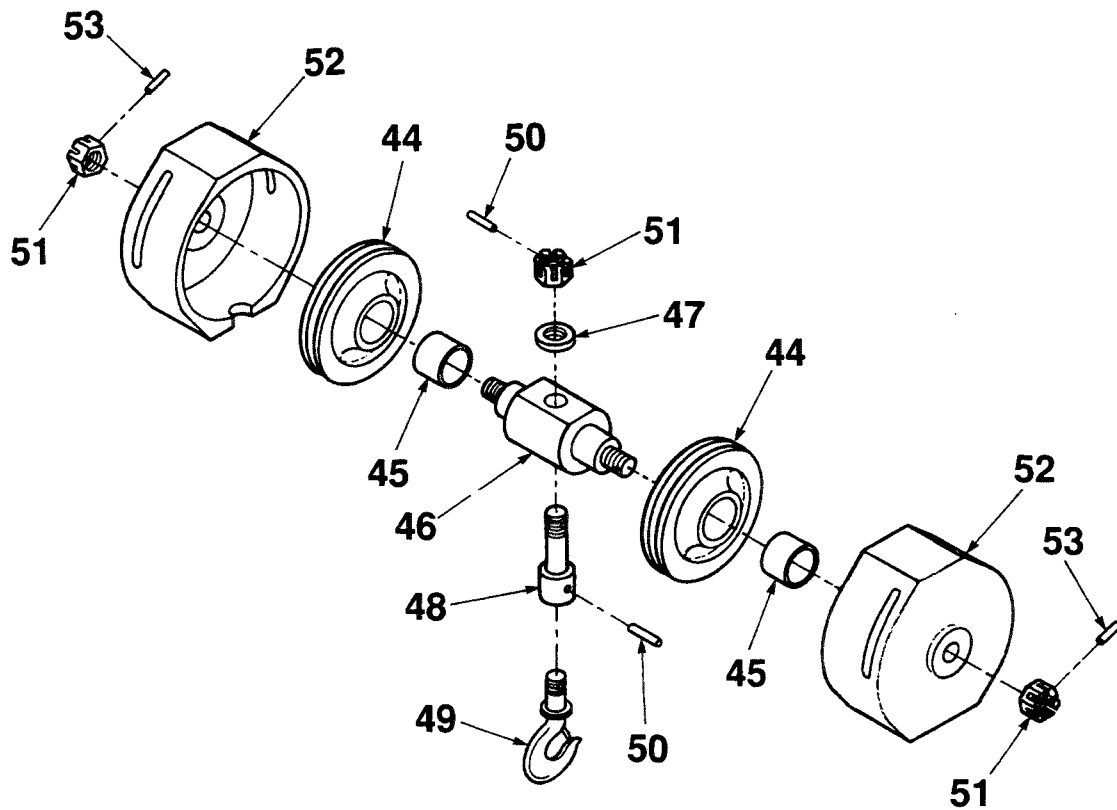

Item No.	Part Name	Part No.
43	Bottom Block Ass'y. (Consists of Index No's. 44-53)	914JG28
44	Sheave	28J14
45	Bushing	530K10
46	Yoke	122J18
47	Bearing	CB-510
48	Shank Ext.	124J10
49	Hook & Latch	3J14S
50	Pin	H-5219
51	Nut	H-3922P
52	Cover	30J23
53	Pin	H-5234

**FIGURE 7-9C BOTTOM BLOCK (1 & 2 TON)
LOW HEADROOM & TRUE VERTICAL LIFT MODELS**

Index No.	Part Name	Part No.
1	Load Pin	103K1
2	Washer (1/8 Thick)	H-4211
3	Washer (.135 Thick)	H-4209
4	Washer (.075 Thick)	H-4210
5	Pinion	420K1
6	Retaining Ring	H-5501
7	Tie Cable Assembly:	
	1 & 2-Ton, 22 Ft. Lift	955JG37
	1 & 2-Ton, 35 Ft. Lift	955JG30
	1 & 2-Ton, 44 Ft. Lift	955JG38
	3-Ton, 22 Ft. Lift	955JG38
	Any Other Lift	Consult Factory
8*	Splice Cap	H-7519
9*	Insulator, Splice Cap	H-7520
10	Nut, Elastic Stop	H-3945
11	Wheel:	
	Plain (1 & 2-Ton)	45K10
	Plain (3-Ton)	45K20
	Drive (1 & 2-Ton)	45K1
	Drive (3-Ton)	45K2
12	Axle:	
	1 & 2-Ton	102K1
	3-Ton	102K2
13	Spacer (1 & 2-Ton Only)	200K1
14	Bearing:	
	1 & 2-Ton	500K4
	3-Ton	500K5
15	Retaining Ring:	
	1 & 2-Ton	H-5528
	3-Ton	H-5530
16	Washer (1/8 Thick)	H-4211
17	Gear	420K2
18	Dowel Pin	H-5384
19	Screw	H-1204
20	Decal	677J7
21	Cable Connector	H-7609
22	Side Plate Weldment:	
	1 & 2-Ton	5KG4
	3-Ton	5KG31
23	Retaining Ring (3-Ton only)	H-5529

*Not Illustrated

**FIGURE 7-10A. TROLLEY GENERAL ASSEMBLY
(SINGLE SPEED HOIST, SINGLE SPEED TROLLEY)**

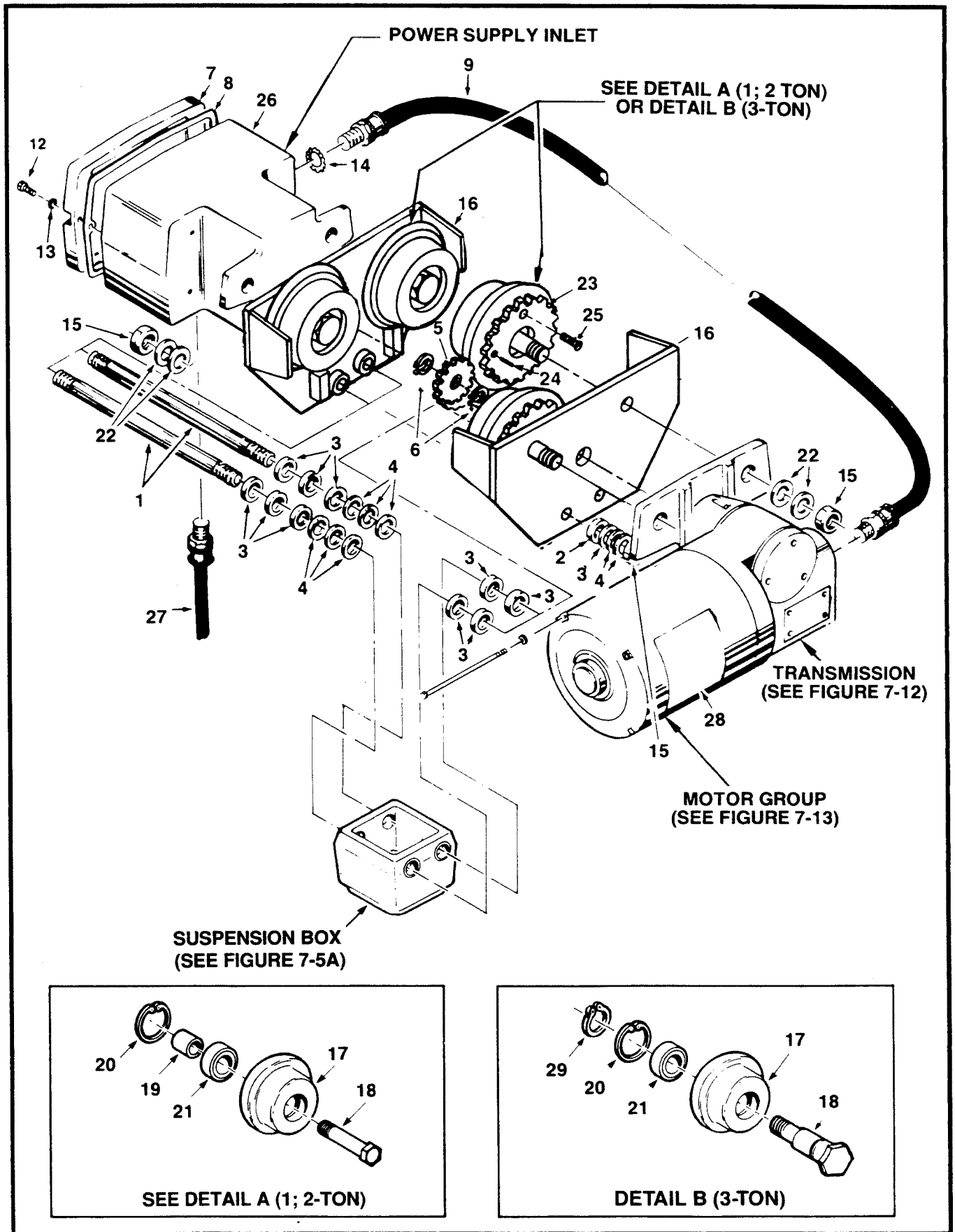
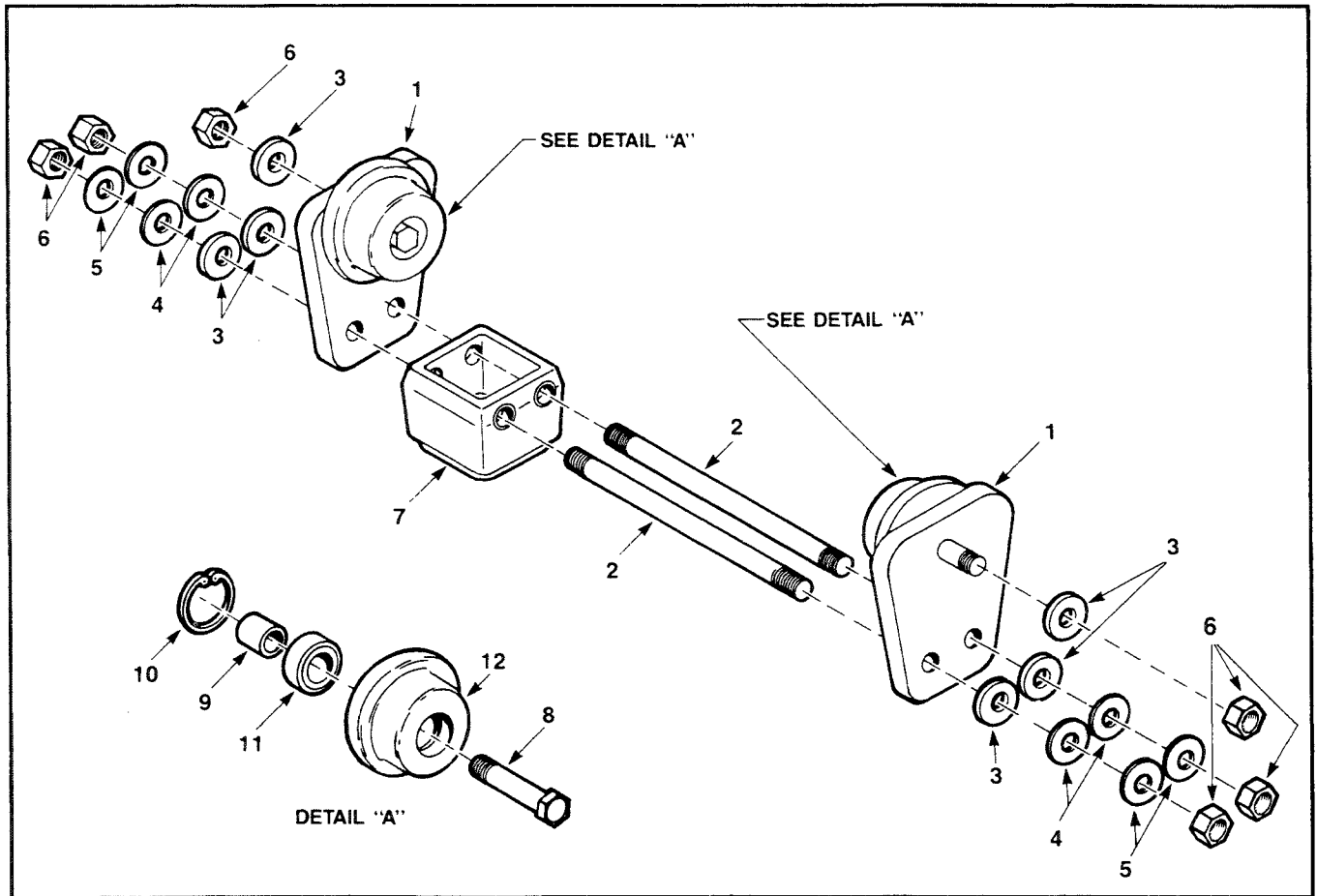

**FIGURE 7-10B. TROLLEY GENERAL ASSEMBLY
(SINGLE SPEED HOIST, TWO SPEED TROLLEY,
TWO SPEED HOIST, SINGLE SPEED TROLLEY,
TWO SPEED HOIST, TWO SPEED TROLLEY)**

Index No.	Part Name	Part No.	Index No.	Part Name	Part No.
1	Load Pin	103K1	21	Bearing:	
2	Washer (1/8 Thick)	H-4211		1 & 2-Ton	500K4
3	Washer (.135 Thick)	H-4209		3-Ton	500K5
4	Washer (.075 Thick)	H-4210	22	Washer (1/8 Thick)	H-4211
5	Pinion	420K1	23	Gear	420K2
6	Retaining Ring	H-5501	24	Dowel Pin	H-5384
7	Cover, Control Box	36K3	25	Screw	H-1204
8	Gasket	560K4	26	Control Box:	
9	Tie Cable Assembly:			1 & 2 Ton	36K1
	Two Speed Hoist,			3-Ton	36K2
	One Speed Trolley	955KG3	27	Interconnection Cable	
	One Speed or			Assembly (1 & 2-Ton)	
	Two Speed Hoist,			Two Speed Hoist, One Speed	
	Two Speed Trolley	955KG4		Trolley (22 Ft. Lift)	954KG18
10*	Splice Cap	H-7519		One Speed or Two Speed	
11*	Insulator, Splice Cap	H-7520		Hoist, Two Speed Trolley	
12	Screw	S-44-4		(22 Ft. Lift)	954KG19
13	Lock Washer	H-4084-P		Two Speed Hoist, One Speed	
14	Lock Nut	H-7569		Trolley (35 Ft. Lift)	954KG20
15	Nut, Elastic Stop	H-3945		One Speed or Two Speed	
16	Side Plate Weldment:			Hoist, Two Speed Trolley	
	1; 2-Ton	5KG4		(35 Ft. Lift)	954KG21
	3-Ton	5KG31		Any Other Lift	Consult
17	Wheel:			Interconnection Cable	Factory
	Plain (1; 2 Ton)	45K10		Assembly (3-Ton):	
	Plain (3-Ton)	45K20		Two Speed Hoist, One Speed	
	Drive (1; 2-Ton)	45K1		Trolley (22 Ft. Lift)	955KG22
	Drive (3-Ton)	45K2		One Speed or Two Speed	
18	Axle:			Hoist, Two Speed Trolley	955KG23
	1; 2-Ton	102K1		(22 Ft. Lift)	Consult
	3-Ton	102K2		Any Other Lift	Factory
19	Spacer (1; 2-Ton Only)	200K1		Decal	677J7
20	Retaining Ring:		28	Retaining Ring (3-Ton only)	H-5529
	1; 2-Ton	H-5528	29		
	3-Ton	H-5530			

*Not Illustrated

**FIGURE 7-10B. TROLLEY GENERAL ASSEMBLY
(SINGLE SPEED HOIST, TWO SPEED TROLLEY,
TWO SPEED HOIST, SINGLE SPEED TROLLEY,
TWO SPEED HOIST, TWO SPEED TROLLEY)**



Index No.	Part Name	Part No.	Index No.	Part Name	Part No.
1	Side Plate	5K56	8	Axle	102K1
2	Load Pin	103K1	9	Spacer	200K1
3	Washer ($\frac{1}{8}$ Thick)	H-4211	10	Retaining Ring	H-5528
4	Washer (.135 Thick)	H-4209	11	Bearing	500K4
5	Washer (.075 Thick)	H-4210	12	Wheel	45K7
6	Nut	H-3945			
7	Suspension Box (Ref. See Figure 7-5A)	50J44A			

**FIGURE 7-11. PLAIN TROLLEY
(TWO WHEEL)**

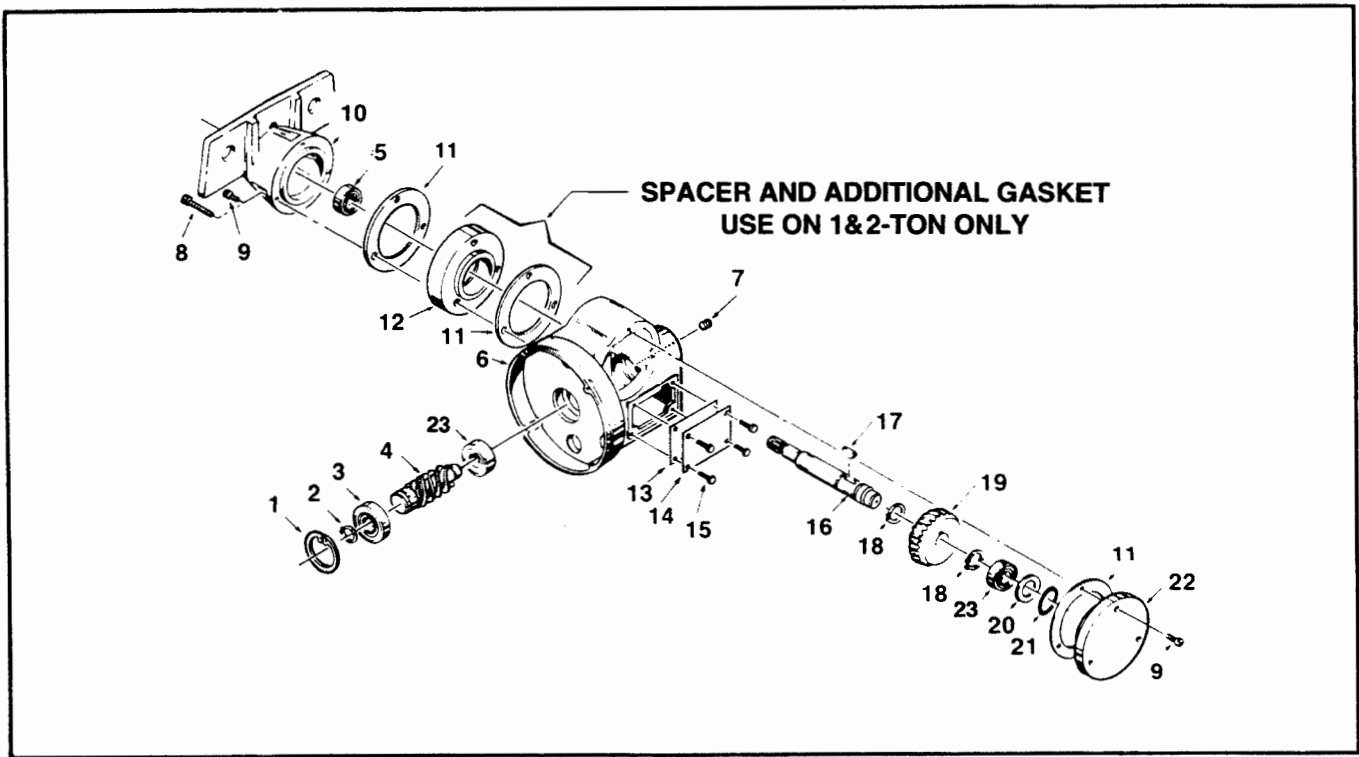

Index No.	Part Name	Part No.	Index No.	Part Name	Part No.
1	Retaining Ring	SK2658-6	12	Spacer (Used on 1&2-Ton only)	201K13
2	Retaining Ring	H-5549	13	Gasket	560K3
3	Bearing	JF-504-2	14	Splice Plate	295K1
4	Worm:		15	Screw	H-1009-P
	35 FPM	485K21	16	Shaft:	
	75 FPM	485K22		1&2-Ton	100K13
5	Bearing	500K3		3-Ton	100K12
6	Gear Housing	39K22	17	Woodruff Key	S-23-15
7	Plug	S-25-13	18	Retaining Ring	H-5527
8	Screw (Used on 1&2-Ton only)	S-49-3	19	Worm Gear:	
9	Screw	H-2215		35 FPM	487K4
10	Adapter Housing:			75 FPM	487K3
	1&2-Ton	38K60A	20	Shim Washer	202K1
	3-Ton	38K61A	21	"O" Ring	H-5609
11	Gasket	560K2	22	End Cap	32K3
			23	Bearing	500K7

FIGURE 7-12. TROLLEY TRANSMISSION

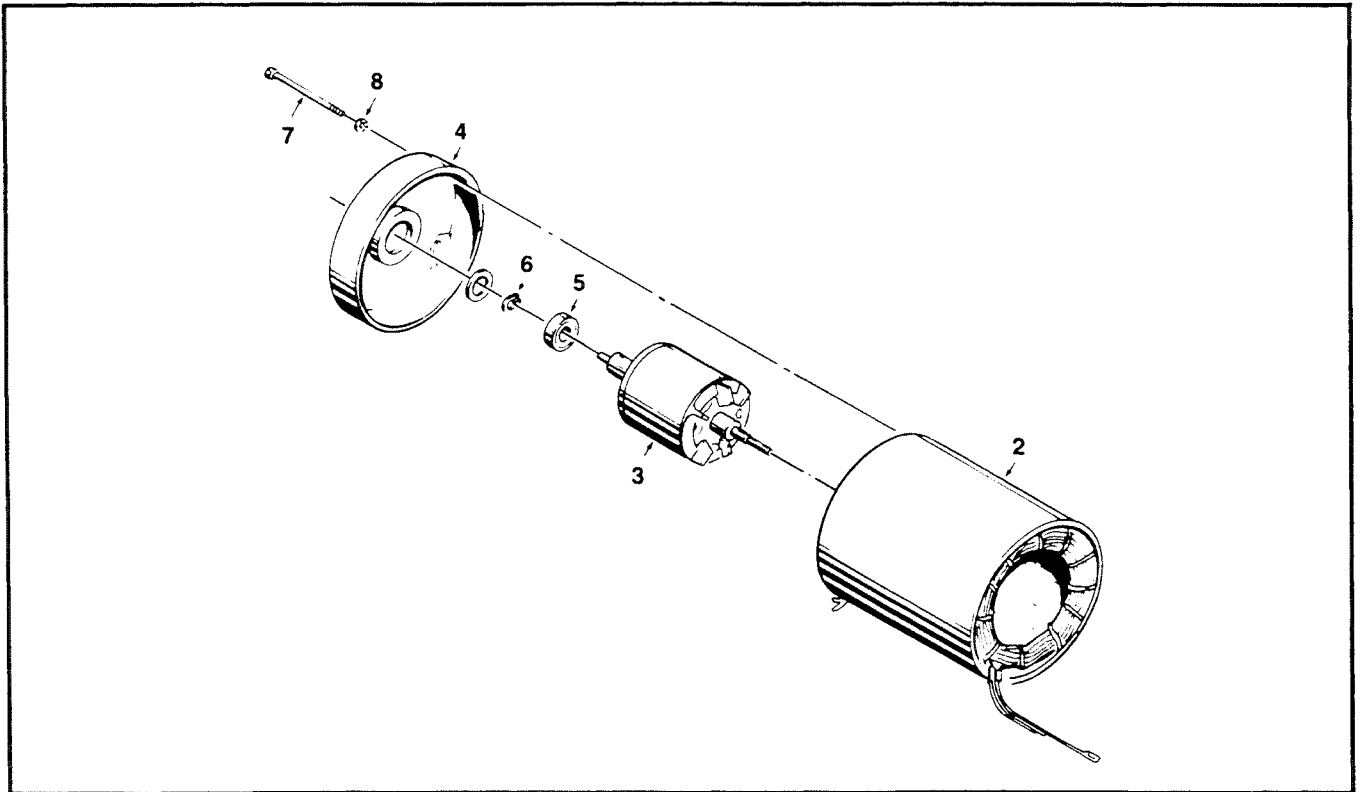

Index No.	Part Name	Part No.	Index No.	Part Name	Part No.
1	Motor Complete:			(Two Speed,	
	(Single Speed, 35 FPM, ¼ HP)	JL-863-1M		75/25 FPM, ½ HP)	JL-873-2M
	208, 230/460V, 3 PH	JL-863-5M		208, 230V, 3 PH	JL-873-6M
	575V, 3 PH			460V, 3 PH	JL-873-10M
	(Single Speed, 75 FPM, ½ HP)	JL-863-2	2	575V, 3 PH	*
	208, 230/460V, 3 PH	JL-863-6	3	Stator (Not available separately)	*
	575V, 3 PH		4	Rotor & Shaft	*
	(Two Speed,		5	End Shield	*
	35/12 FPM, ¼ HP)	JL-873-1M	6	Bearing	*
	208, 230V, 3 PH	JL-873-5M	7	Retaining Ring	*
	460V, 3 PH	JL-873-9M	8	Screw, Motor Mount	*
	575V, 3 PH			Lock Washer	*

*For individual motor parts, contact your Duff-Norton Distributor and supply complete motor nameplate data.

FIGURE 7-13. TROLLEY MOTOR PARTS

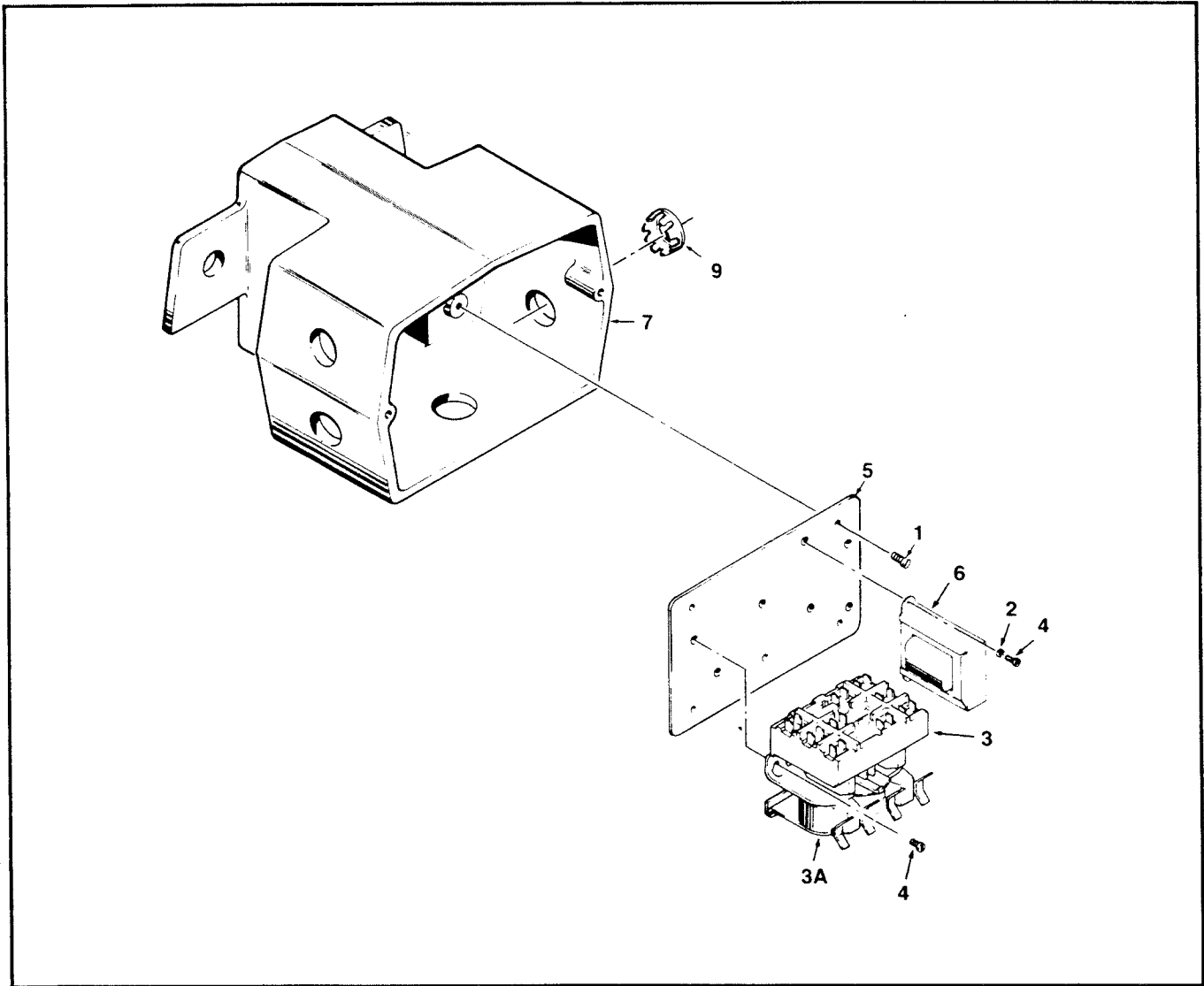

Index No.	Part Name	Part No.	Index No.	Part Name	Part No.
1	Screw	H-1005-P	6	Transformer: (10 VA)	
2	Lock Washer	H-4158		Pri. 208, 230/460V,	
3	Magnetic Reversing Switch:			Sec. 24V, 50/60 Hz	JF-821-3
	24V Control	820K2		Pri. 208, 230/460V,	
	115V Control	820K317		Sec. 115V, 50/60 Hz	JF-821
3A	Coil:			Pri. 575V,	
	24V	820K301		Sec. 24V, 50/60 Hz	JF-821-9
	115V	820K302		Pri. 575V,	
3B*	Replacement Contact Kit			Sec. 115V, 50/60 Hz	JF-821-2
	(Includes stationary and		7	Control Box:	
	movable contacts and			1; 2-Ton	36K1
	springs for one magnetic			3-Ton	36K2
	reversing switch)	820K300	8*	Jumper Wire	JF-940-7
4	Screw	H-2751	9	Hole Plug	H-6286
5	Panel Plate	257K267			

*Not Illustrated

**FIGURE 7-14A. TROLLEY CONTROL, SINGLE SPEED
(SINGLE SPEED TROLLEY, TWO SPEED HOIST)**

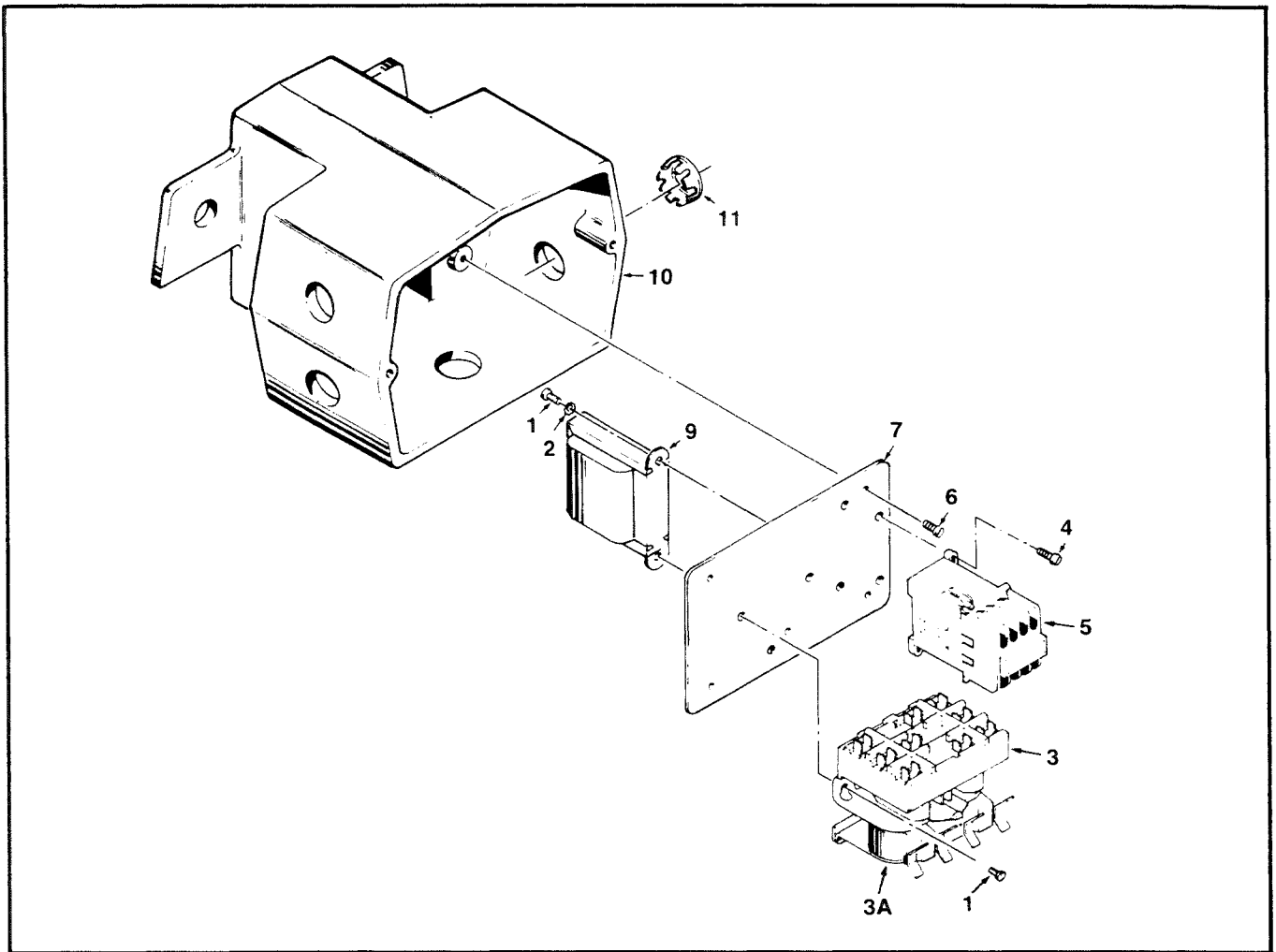

Index No.	Part Name	Part No.	Index No.	Part Name	Part No.
1	Screw	H-2751	6	Screw	H-1005-P
2	Lock Washer	H-4158	7	Panel Plate	257K267
3	Magnetic Reversing Switch: 24V Control 115V Control	820K2 820K317	8*	Jumper Wire	JF-940-7
3A	Coil: 24V 115V	820K301 820K302	9	Transformer: (20 VA) Pri. 208, 230/460V, Sec. 24V, 50/60 Hz Pri. 208, 230/460V, Sec. 115V, 50/60 Hz	JF-821-15 JF-821-17
3B*	Replacement Contact Kit (Includes stationary and movable contacts and springs for one magnetic reversing switch)	820K300	10	Pri. 575V, Sec. 24V, 50/60 Hz Pri. 575V, Sec. 115V, 50/60 Hz	JF-821-16 JF-821-20
4	Screw	H-1901		Control Box: 1; 2-Ton 3-Ton	36K1 36K2
5	Speed Control Relay: 24V Control 115V Control	820J3 820J4	11	Hole Plug	H-6286

*Not Illustrated

**FIGURE 7-14B. TROLLEY CONTROL, TWO SPEED
(TWO SPEED TROLLEY WITH ONE OR TWO SPEED HOIST)**

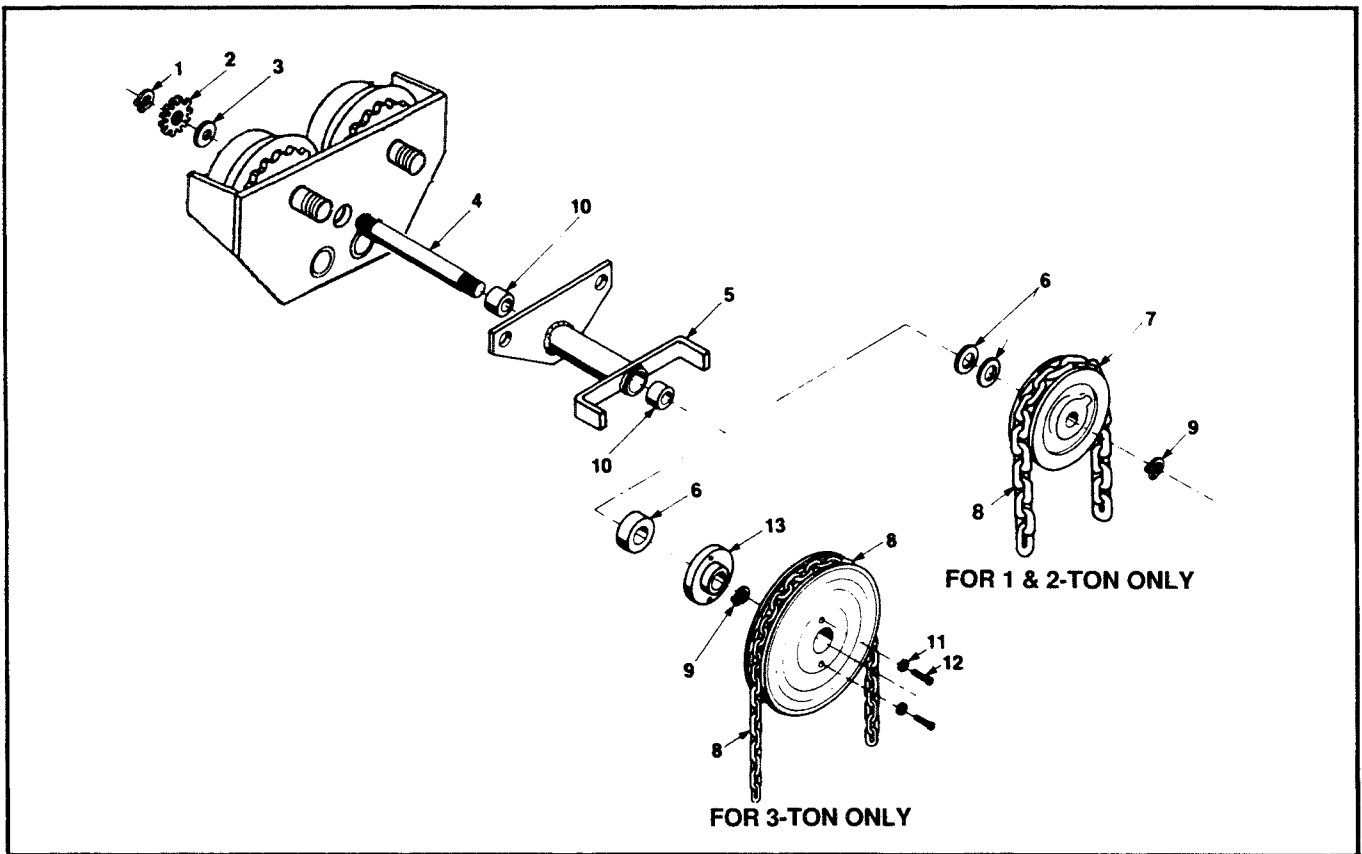

Index No.	Part Name	Part No.	Index No.	Part Name	Part No.
1	Retaining Ring	H-5501	7	Hand Chain Wheel:	
2	Pinion	420K1		1 & 2-Ton	33K23
3	Spacer Bearing (1/16 Thick)	525K2		3-Ton	33K13
4	Gear Shaft	100K14	8	Hand Chain (Specify length)	53A
5	Sleeve and Adapter Assembly:		9	Retaining Ring	H-5527
	1 & 2-Ton	51KG1	10	Sleeve Bushing	530K6
	3-Ton	51KG2	11	Washer	H-4138
6	Spacer Bearing (1/8 Thick)	525K1	12	Bolt	H-2304
			13	Hub Adapter	51K4

FIGURE 7-16. GEARED TROLLEY

COFFING[®] HOISTS

WARRANTY

Every hoist is thoroughly inspected and tested prior to shipment from the factory. Should any problem develop, return the complete hoist prepaid to your nearest Coffing Hoists Authorized Warranty Repair Station. If inspection reveals that the problem is caused by defective workmanship or material, repairs will be made without charge and the hoist will be returned, transportation prepaid. This warranty does not apply where: **(1)** deterioration is caused by normal wear, abuse, improper or inadequate power supply, eccentric or side loading, overloading, chemical or abrasive actions, improper maintenance, or excessive heat; **(2)** problems resulted from repairs,

modifications, or alterations made by persons other than factory or Coffing Authorized Warranty Repair Stations personnel; **(3)** the hoist has been abused or damaged as a result of an accident; **(4)** repair parts or accessories other than those supplied by Coffing Hoists are used on the hoist. Equipment and accessories not of the seller's manufacture are warranted by the manufacturer.

Except as stated herein, Coffing Hoists makes no other warranties, express or implied, including warranties or merchantability and fitness for a particular purpose.

WARNING

Overloading and Improper Use Can Result In Injury

To Avoid Injury:

- Do not exceed working load limit, load rating, or capacity.
- Do not use to lift people or loads over people.
- Use only alloy chain and attachments for overhead lifting.
- Read and follow all instructions.

Coffing Hoists • Country Club Road • P.O. Box 779 • Wadesboro, NC 28170 USA
Customer Service: Tel. (800) 477-5003 (704) 694-2156 • FAX (800) 374-6853 (704) 694-6829