

**2000# Double
Line Lift Capacity**

**MY-TE Winch and Hoist
OPERATION and MAINTENANCE**

**OF
All 115 Volt AC Winches
Main Parts List for 100AB, 150AB
Used with Supplement Parts List for 800B**

READ THIS BEFORE OPERATING UNIT

INSTALLATION:

Mount on clean, flat surface. Bolt down with 6-1/2" bolts. For ease of service, we do not recommend welding frame to surface.

Unit should be plugged into a 115 Volt A.C. grounded receptacle. Use of extension cords may cause power loss at full capacity. Make sure the voltage and type of current stamped on the name plate is used. The 115 Volt units require 19 amps. service for maximum lift, and uses a manual reset circuit breaker rated at 20 amps.

For additional safety, a power disconnect may be installed to provide a means of cutting power in place of using the power cord to disconnect.

Before the unit is wall mounted, or mounted upside down, remove P/N 286260 Oil Plug Valve and exchange with P/N 286250 Oil Plug located below the control box on the worm gear housing cover.

CABLE CONNECTION AND CABLE SAFETY:

Maintain at least 4 wraps of cable on the drum at the maximum reach. The drum cable clamp is not designed to hold load. Inspect the winch, sheaves and cable frequently. Especially watch for frayed cable, loose parts and worn components which may be hazardous. Use the correct size and length of cable for the job. We recommend use of 1/4" cable for most jobs up to 2000 lb. double line. Always provide a 5 to 1 safety factor.

The cable tensioner is designed to prevent the cable from riding over the drum flanges and to maintain a constant pressure against the cable to keep it from binding.

When installing the cable, cable should be placed between the drum and the tensioner, bringing cable around drum to hold in flange. Push cable through hole and secure screws so that they do not extend through the drum flange and interfere with cable tensioner. Be sure cable is wrapped as evenly as possible on drum.

For best results, use only enough cable to meet specific job requirements.

Worn cable is dangerous. Replace cable that has become frayed, broken, kinked or abraded.

OPERATION:

These units are designed for intermittent duty operation. Mfg. recommends a 25% duty cycle. That is, for good motor life, usage of 15 minutes out of one hour is preferable.

To prevent shock loading, slowly remove slack from cable before full load is moved.

The remote control switch is a special 4 wire control which is part of the dynamic brake control system. Changing the switch to some other type will eliminate the braking action. Use only factory provided switch.

Remote switch provides forward and reverse control through a 24 volt transformer. Lifting power is the same in either direction.

**MY-TE WINCH-HOISTS ARE DESIGNED
FOR MATERIAL HANDLING USAGE.**

MAINTENANCE:

Check all sheaves, rollers and areas of friction. Be sure they turn freely. Misalignment of cable, dragging sheaves, or rollers will consume a great amount of power.

If the unit is installed outside, be sure to provide a cover to protect motor and controls from the weather. When the unit is in operation be sure cover is completely removed.

Periodic inspection of switch and power cord should be made to detect any damage or cuts which would require replacement.

The gearbox oil is shared between the spur and worm gear housings. The factory-installed oil is a Shell product; Omala 68. It is an EP type industrial gear oil, ISO Grade 68. If this is not available, an SAE 20 weight, non-detergent motor oil is acceptable. Standard capacity is 18 ounces.

TROUBLE SHOOTING AND REMEDIES:

CAUTION: BEFORE SERVICING OR INSPECTING UNIT FOR PROBLEMS BE SURE TO DISCONNECT POWER.

If the unit does not run, check power supply. Be sure correct voltage and frequency are being used. Remove power plug and remove control box cover. Visually inspect for loose wires, stuck contacts on relays, and screws which may have worked loose.

If the unit runs but braking is not instantaneous, check resistors and motor brush condition. Bad resistors will affect the dynamic braking. Check resistors for cracked porcelain and exposed wire. Replace as needed. To check resistors electrically, test individually with a continuity test. On ohmmeter, each resistor should have a value of 4 ohms and together a resistance of 2 ohms.

Care should be taken to keep the armature in good condition which may be accomplished by lightly rubbing commutator with a rubstone.

Check brushes to see that they seat on the commutator and are not cracked or badly worn. Replace as needed. Brush springs should provide enough tension to keep brushes seated.

If the unit does not operate properly after the above remedies, contact a qualified electrician or the factory.

WARRANTY:

All My-te winch-hoists are designed for material handling use only. My-te Products, Inc. warrants each My-te winch-hoist to be free of defects in material and workmanship for a period of one year. This warranty does not cover abuse, neglect or use above or beyond rated capacity and duty cycle. Warranty coverage includes shipping charges, one way, by standard ground service. Warranty does not cover cost of installation or removal of winch-hoist from service or loss due to downtime or time out of service. My-te will not reimburse unauthorized warranty expense. The final responsibility for fit of winch-hoist with application rests with end user. The warranty is void if the winch-hoist is altered or parts substituted. This warranty is limited to repair or replacement at manufacturer's factory or a point designated by the manufacturer. Inspection by the manufacturer will determine manufacturer's liability.

100AB Parts List

COMMON FASTENERS AND OTHER ITEMS NOT SHOWN HERE ARE AVAILABLE THROUGH MY-TE PARTS DEPT OR YOUR MY-TE DEALER.

ITEM	QTY	PART No.	DESCRIPTION	ITEM	QTY	PART No.	DESCRIPTION	ITEM	QTY	PART No.	DESCRIPTION	ITEM	QTY	PART No.	DESCRIPTION
1	1	052531	Main Shaft, Long w/o Clutch	21	2	211060	Needle Bearing	41	2	351020	Key, Worm Shaft	51	2	552040	Strain Relief, Cord & Switch
		052543	Main Shaft, Short-Model 150AB	22	2	212010	Thrust Washer	42	3	351030	Key, Main Shaft	52	1	561030	Relay, Power DPDT w/Aux Switch
2	1	058010	Worm Shaft Assy	23	1	218010	Bearing Assy, Flange	43	1	351050	Key, Pinion	53	1	561031	Relay, Power DPDT
3	1	068140	Drum Assy, Long Cast	24	2	218020	Bearing Assy, Worm Shaft	44	1	448120	Brake Motor Assy	54	1	562011	Transformer, 115/24 VAC w/Term. Block
		068060	Drum Assy, Short - 150AB	25	1	241010	Oil Seal, Main Shaft	44a	2	443020	Brush Cap, Current Apps	55	1	562530	Circuit Breaker, 20amp 115v
4	1	081510	Cap, Worm Gear Hsg	26	1	241020	Oil Seal, Motor Shaft	44b	1	443030	Rectifier Assy, Current Apps	56	1	568040	Resistor Assy
5	1	082011	Cover, WGH Closed	27	1	241510	Gasket, Worm Gear Hsg	44c	1	443040	Motor Brake, Current Apps	57	1	568050	Capacitor Assy
6	1	082191	Cover, Motor	28	1	241521	Gasket, Spur Gear Hsg	44d	1	448130	Brush Sel, Current Apps	58	1	828090	Drum Cable Clamp Assy
7	1	088090	Housing, Worm Gear / Studs	29	2	241530	Gasket, Worm Hsg Cap 1/32	**		518521	Complete Control Box with Switch & Power Cord				
8	1	088160	Cover, Spur Gear Hsg/Brig	30	2	241540	Gasket, Worm Hsg Cap .010	45	1	512020	Panel, Plain				
9	1	088170	Housing, Spur Gear/Brig	31	1	241550	Gasket, Switch Housing	46	1	518010	Control Box w/Brkt & Cover				
10	1	112010	Spur Gear			248022	Seal & Gasket Kit-New Cove	47	1	518261	Panel Assy w/Compts&Brace				
11	1	113010	Worm	32	1	282750	Setscrew, 10-32 x 3/16	48	1	538033	Hand Switch Assy 4 Wire				
12	1	118040	Idler Gear Assy/Shaft	33	4	283020	Screw, 5/16-18 x 1 SHCS	48a	2	531140	Switch, Push Button SPDT				
13	1	118110	Pinion Assy/SS	34	8	283080	Screw, 1/4-20 x 1-1/4 SHCS	48b	1	532021	Switch, Plate/Switch/Guard				
14	1	118160	Worm Gear Assy w/SS	35	3	285750	Stud, WGH 3/8-16 x 1-1/4	48c	2	532550	Guard, Switch				
15	1	148360	Tensioner Bar Assy/HW	36	2	286250	Oil Plug, 1/8 NPT	48d	1	552110	Strain Relief, Pendant				
16	1	148170	Frame Assy, Std Long	37	1	286280	Valve, Oil Plug 1/8 NPT	49	1	548030	Power Cord Assy				
		148030	Frame Assy, Short 150AB	38	8	287041	Lockwasher, 1/4 HC	50	1	552020	Strain Relief, Motor				
17	1	171280	Spacer, Thick Main Shaft	39	2	321520	Snap Ring Worm Shaft								
18	1	171310	Spacer, Thin Main Shaft	40	1	321530	Snap Ring WGH								
19	1	182032	Brace, Control Box												
20	2	211010	Bearing, Main Shaft												



100AB Parts Drawing

P/N 742011

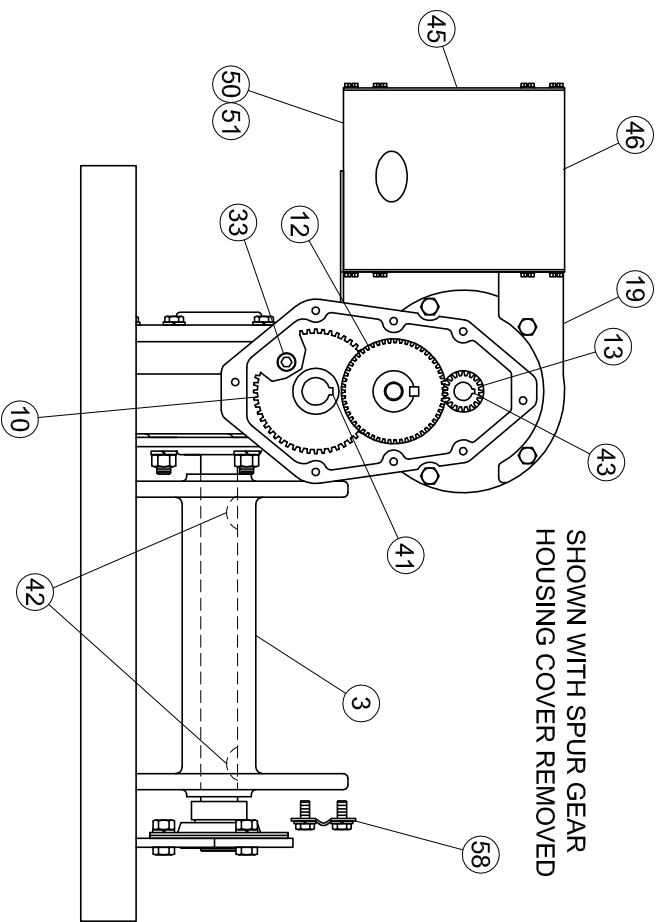
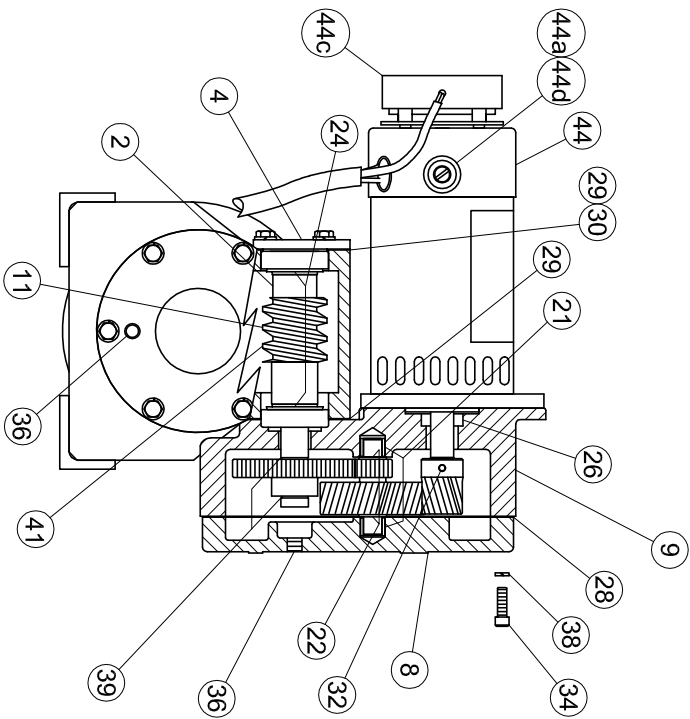
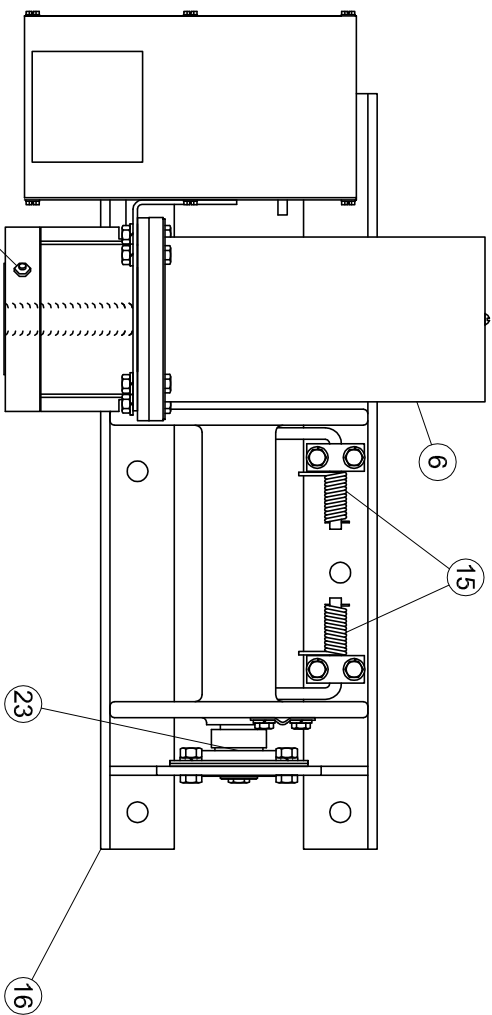
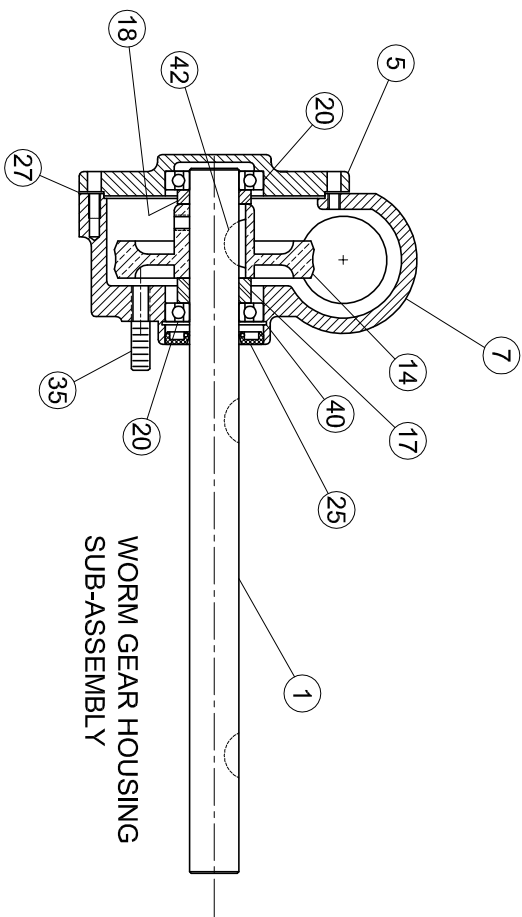

POWER CORD
P/N 548030 (REF)

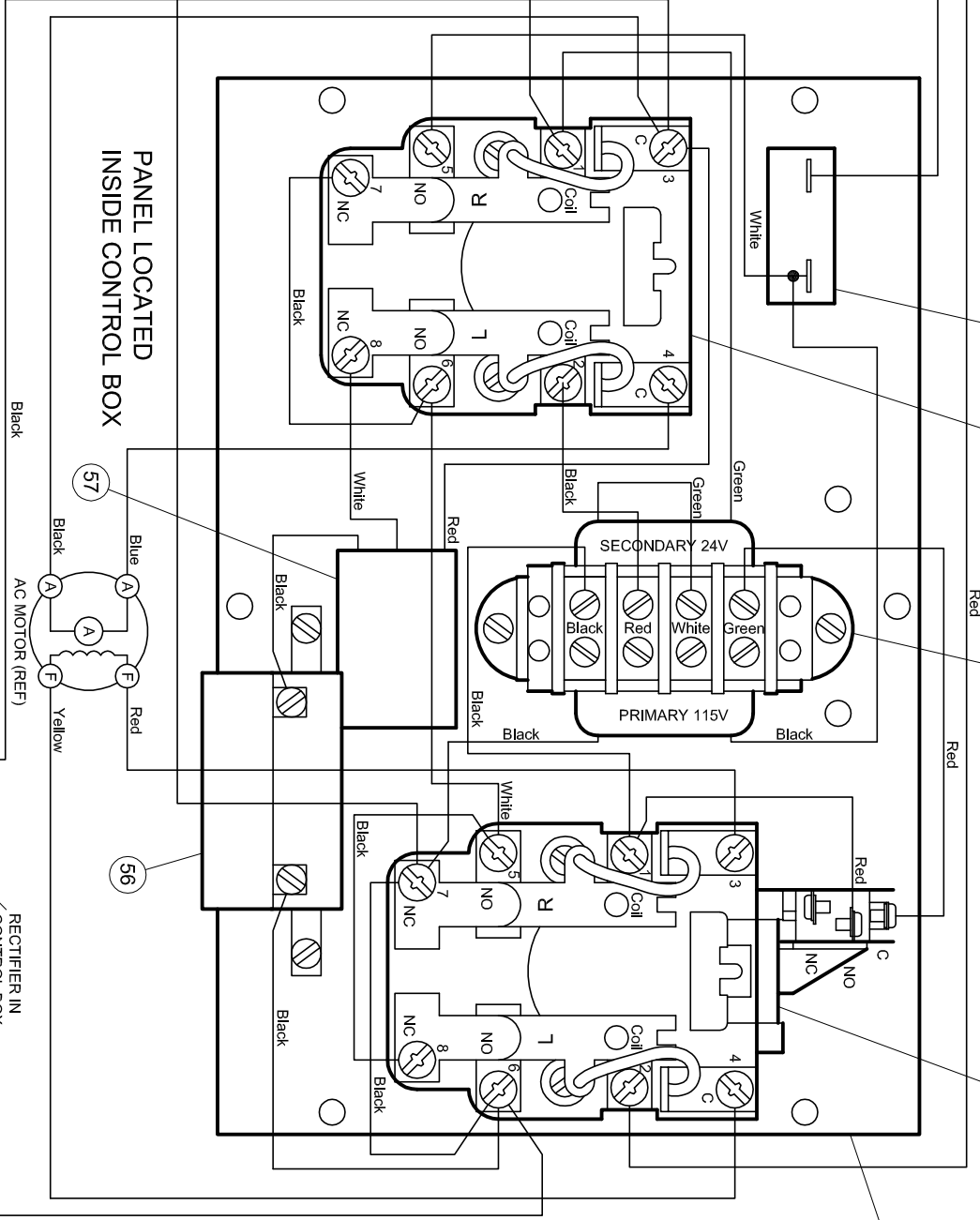

PANEL LOCATED
INSIDE CONTROL BOX

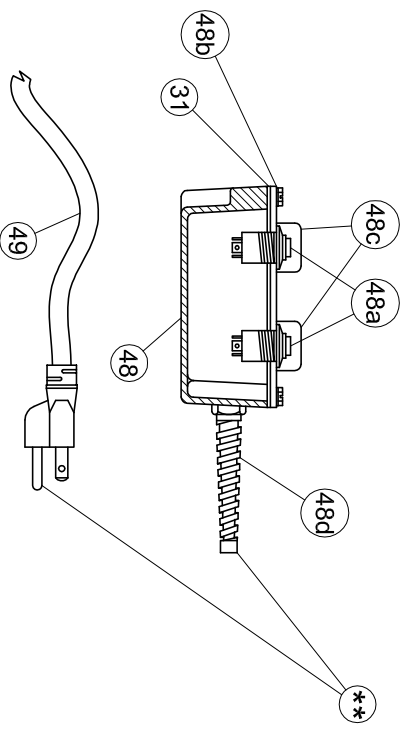

SWITCH CORD P/N 541020
CONNECT WIRES TO TERMINAL
STRIP AT CORRESPONDING
COLOR MARK

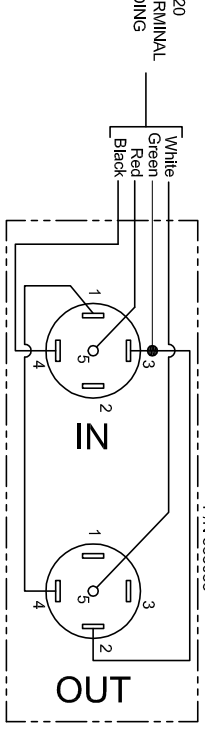

HAND SWITCH ASSEMBLY
P/N 539033

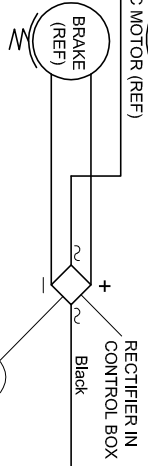

RECTIFIER IN
CONTROL BOX

