

# Panther

## Installation instructions

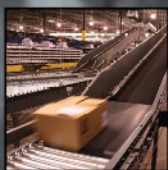

### Receivers

PN-RX-MNB4

(PN-R15-1)

PN-RX-MDB-10

(PN-R15-2)

PN-RX-MNA4

(PN-R15-7)

PN-RX-MDA-10

(PN-R15-8)

---

## CONTENTS

---

Chapter 1: CUSTOMER INFORMATION .....	3
Chapter 2: FUNCTIONAL SAFETY .....	5
Chapter 3: PRODUCT DESCRIPTION .....	7
Base board .....	7
Relay expansion board .....	7
Terminal block for input power .....	8
Function LEDs indication .....	8
Error codes .....	9
Technical data .....	9
Current consumption .....	9
Mechanical installation .....	10
Chapter 4: INSTALLERS' GUIDE .....	11
Radio mode .....	11
Logout .....	11
Relay functions .....	11
Operating modes .....	12
Chapter 5: GUARANTEE, SERVICE, REPAIRS AND MAINTENANCE .....	18
Chapter 6: REGULATORY INFORMATION .....	19
Chapter 7: FREQUENT TERMS .....	20

---

---

## CHAPTER 1: CUSTOMER INFORMATION

### THANK YOU FOR PURCHASING A TELE RADIO AB PRODUCT

READ ALL INSTRUCTIONS AND WARNINGS CAREFULLY BEFORE MOUNTING, INSTALLING AND CONFIGURATING THE PRODUCTS.

These instructions are published by Tele Radio AB and are not subject to any guarantee. The instructions may be removed or revised by Tele Radio AB at any time and without further notice. Corrections and additions will be added to the latest version of the instructions.

**IMPORTANT!** These instructions are directed to installers. The instructions containing information about the installation and configuration of the radio remote control unit on the machine are not intended to be passed on to the end user. Only information that is needed to operate the machine correctly by radio remote control may be passed on to the end user.

Tele Radio AB products are covered by a guarantee/warranty against material, construction or manufacturing faults. During the guarantee/warranty period, Tele Radio AB may replace the product or faulty parts. Work under guarantee/warranty must be carried out by Tele Radio AB or by an authorized service center specified by Tele Radio AB. Contact your Tele Radio AB representative if you need support or service.

©Tele Radio AB  
Datavägen 21  
SE-436 32 ASKIM  
SWEDEN  
Tel: +46-31-748 54 60  
Fax: +46-31-68 54 64  
[www.tele-radio.com](http://www.tele-radio.com)

---

## WARNINGS & RESTRICTIONS

**WARNING!** Tele Radio AB remote controls are often built into wider applications. We recommend that the system is equipped with a wired emergency stop where necessary.

### INSTALLING, CONNECTING AND MOUNTING

- Only permit licensed or qualified personnel to install the product.
- Switch off the power supply to the receiver before connecting the equipment.
- Check that the power supply is connected to the correct connection terminal.
- To utilize the safety of the system, use the stop relays in the safety circuitry of the object that you want to control.
- Do not use damaged cables. Cables must not hang loose.
- Avoid installing in areas affected by strong vibrations.
- Place the receiver well away from wind, damp and moisture.
- Cable glands and vent plugs must face downwards to prevent water from gaining access.

### THE USER

- Only permit qualified personnel to access the transmitter and operate the equipment.
- Make sure that the user follows the instructions.
- Make sure that the user satisfies the age requirements in your country for operating the equipment.
- Make sure that the user is not under the influence of drugs, alcohol or medications.
- Make sure that the user does not leave the transmitter unsupervised.
- Make sure that the user always switches the transmitter off when it is not in use.
- Make sure that the user has a clear view of the work area at all times.

### MAINTENANCE

- Use the stop button to start and switch off the transmitter as often as possible.
- If error messages are shown, it is very important to find out what caused them.
- If the stop button is mechanically damaged, contact your representative for service immediately.
- Always contact your representative for service and maintenance work on the product.
- Write down the serial numbers/ID codes of the receivers and transmitters used. This information should be recorded in the "Settings document" for your product (download from our website).
- Avoid registering transmitters in receivers where they are not being used.
- Keep the safety instructions for future reference. Always download the configuration instructions from our website for the latest available version.

## WEEE DIRECTIVE



This symbol means that inoperative electrical and electronic products must not be mixed with household waste. The European Union has implemented a collection and recycling system for which producers are responsible. For proper treatment, recovery and recycling, please take this product to a designated collection point.

Tele Radio AB strives to minimize the use of hazardous materials, promotes reuse and recycling, and reduces emissions to air, soil and water. When a commercially viable alternative is available, Tele Radio AB strives to restrict or eliminate substances and materials that pose an environmental, health or safety risk.

## CHAPTER 2: FUNCTIONAL SAFETY

NOTE! The information in this section applies only to the products specified below.

### Safety function

The safety-related stop function in the radio system complies with EN 13849-1:2008 Category 3 PLd. The stop relays on the receiver unit are controlled by the stop button on the transmitter unit. When the stop button is pressed, the stop relays break the power to the safety-related application. The complete end-user system, including the radio system, enters a safe state. The maximum response time for the safety-related stop function is 500ms.

### Applicable products

The following transmitter and receiver units are designed to comply with the appointed safety requirements:

Receivers: PN-R15-1, PN-R15-2, PN-R15-7, PN-R15-8

Transmitter: PN-T19-2

NOTE! Both the receiver and the transmitter used in the specific end-user system must be compliant.

### Installation

The stop relays on the receiver unit must be correctly installed on the end-user system, to ensure that opened/deactivated stop relays interrupt the power to the safety-related application. The safety level of the stop function can only be credited when used in a complete end-user system that complies with EN 13849-1:2008 Category 3 PLd.

### Configuration

The default configuration of the receiver unit complies with the appointed safety requirements. Any reconfiguration that breaches the safety requirements will be indicated by a LED on the main board of the receiver unit. Before commissioning the radio system, the installer must check the LED indication.

Function LED	Status	Indicates
PLd status LED (red)	ON	Not compliant with PLd
	OFF	Compliant with PLd

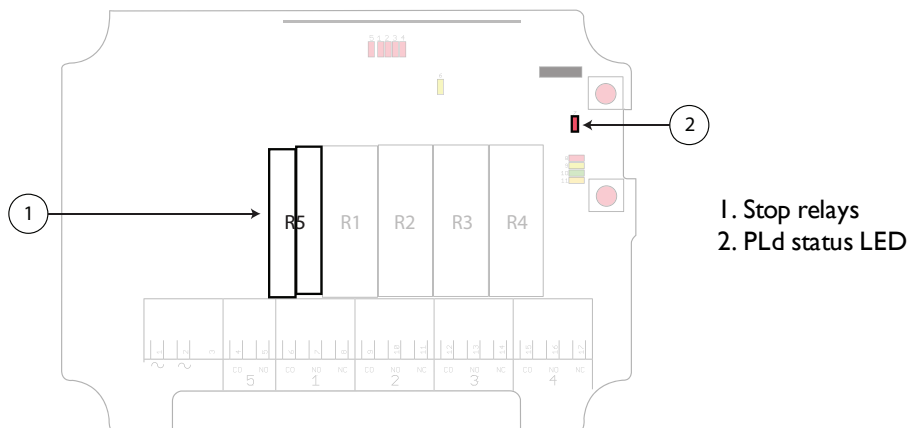

---

**WARNING!** All safety-related parameters must be configured as follows in order to comply with the appointed safety requirements:

- The system must be configured in continuous radio mode
- All relays must be switched off when the radio link is down
- The radio link timeout must be set to a maximum of 500ms
- The login/logout function must be activated
- The Custom ID setting must be deactivated, i.e. the receiver must always use the unique transmitter ID code

## CHAPTER 3: PRODUCT DESCRIPTION

**WARNING!** The receiver must NOT be opened by anyone other than a qualified installer. Make sure that the electricity is switched off before opening the receiver.

### BASE BOARD

**NOTE!** This base board is fitted in the following receiver models:  
PN-R15-1, PN-R15-2, PN-R15-7, PN-R15-8.

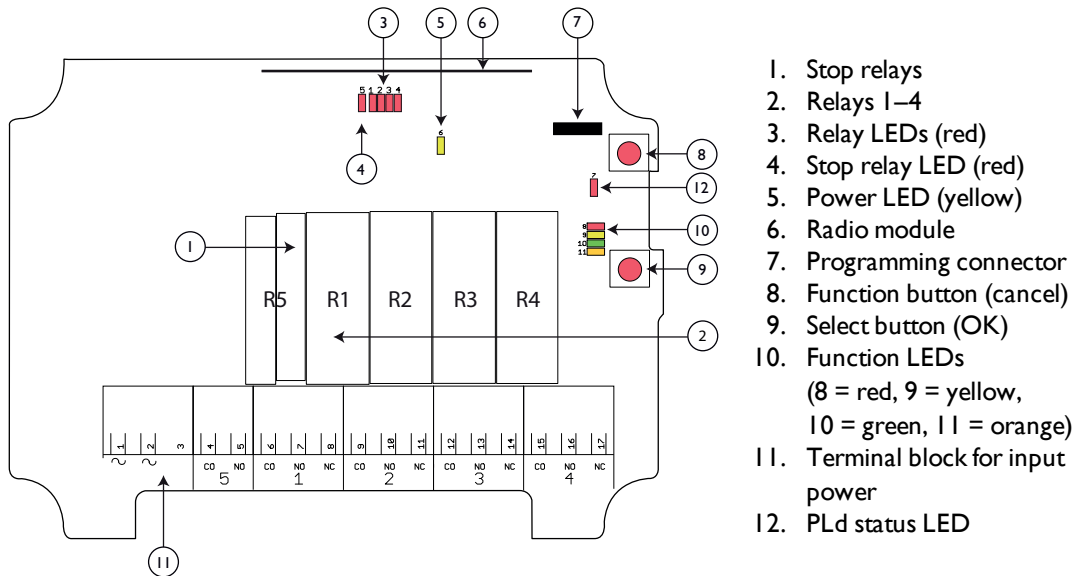

### RELAY EXPANSION BOARD

**NOTE!** This relay expansion board is fitted in the following receiver models:  
PN-R15-2, PN-R15-8

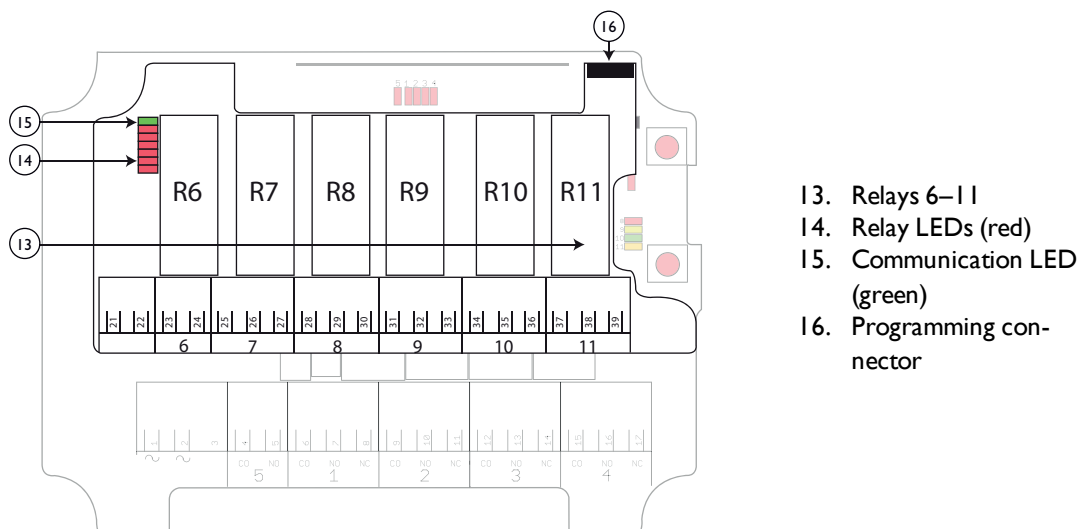

## TERMINAL BLOCK FOR INPUT POWER

**WARNING!** Be sure to connect the input power according to the tables below.

### PN-R15-1, PN-R15-2

<input type="checkbox"/>	<input type="checkbox"/>	<input type="checkbox"/>
1	2	3
48 - 230V AC		

1. 48–230V AC
2. 48–230V AC
3. (not in use)

### PN-R15-7, PN-R15-8

<input type="checkbox"/>	<input type="checkbox"/>	<input type="checkbox"/>
1	2	3
24 - 48V AC		

1. 24–48V AC
2. 24–48V AC
3. (not in use)

## FUNCTION LEDS INDICATION

LED	Colour	Off	On	Indicates
7	red		x	Not compliant with PLd.
		x		Compliant with PLd.
8	red	x		No transmitter is registered.
			x	Flashes once: One or more transmitters are registered. No radio transmission established.
			x	Double flash: One or more transmitters are registered and logged in. No radio transmission established.
			x	Radio transmission established.
9	yellow		x	Receiving a radio packet from a transmitter other than a Panther.
9 10	yellow green		x	Receiving a radio packet from a transmitter set to the radio mode different from that of a receiver.
9 11	yellow orange		x	Receiving a radio packet from a transmitter that is not registered.
10	green		x	Receiving a radio packet, low signal (RSSI).
11	orange		x	Receiving a radio packet, configuration ID not accepted.
10 11	green orange		x	Receiving a radio packet, custom ID not accepted.
9 10 11	yellow green orange		x	1. Receiving a radio packet from a registered transmitter. The receiver is already controlled by another registered transmitter. NOTE! "Radio link" must be activated in the receiver. 2. Load select mode is activated. Incorrect Load is selected on the transmitter.



## ERROR CODES

If an error occurs that requires the attention of Tele Radio AB, all Function LEDs will flash. At the same time, one or more Relay LEDs will light up. Note the Relay LEDs that light up and contact your representative for assistance.

## TECHNICAL DATA

Number of stop relays	2 (potential free*, 6A, 250V AC)
Number of relays	PN-R15-1, PN-R15-7: 4 PN-R15-2, PN-R15-8: 10 (potential free*, 10A, 250V AC)
Input power	PN-R15-1, PN-R15-2: 48–230V AC PN-R15-7, PN-R15-8: 24–48V AC
Digital inputs	0
Radio communication	Simplex
Max. number of registered transmitters	8
IP code	66
Dimensions	120 x 117 x 51 mm / 4.7 x 4.6 x 2 in
Weight	400 g / 0.8 lbs
Operating temperature	- 20 – + 55 °C / - 4 – + 130 °F
Frequency band	2405–2480 MHz
Number of channels	16 (channel 11–26)
Antenna	Internal antenna

\*Potential free means that a supply voltage is needed to get voltage out of a relay.

## CURRENT CONSUMPTION

Input power	Receivers	Min.*	Max.**
24V AC	PN-R15-7, PN-R15-8	0.02A	0.2A
48V AC	PN-R15-1, PN-R15-2, PN-R15-7, PN-R15-8	0.01A	0.09A
115V AC	PN-R15-1, PN-R15-2	0.005A	0.03A
230V AC	PN-R15-1, PN-R15-2	0.003A	0.02A

\*Minimum current consumption = Receiver powered, no active relays, no radio link established

\*\*Maximum current consumption = Receiver powered, all relays on the receiver active, radio link established

# MECHANICAL INSTALLATION

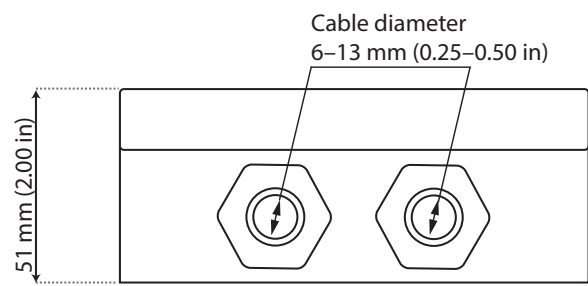
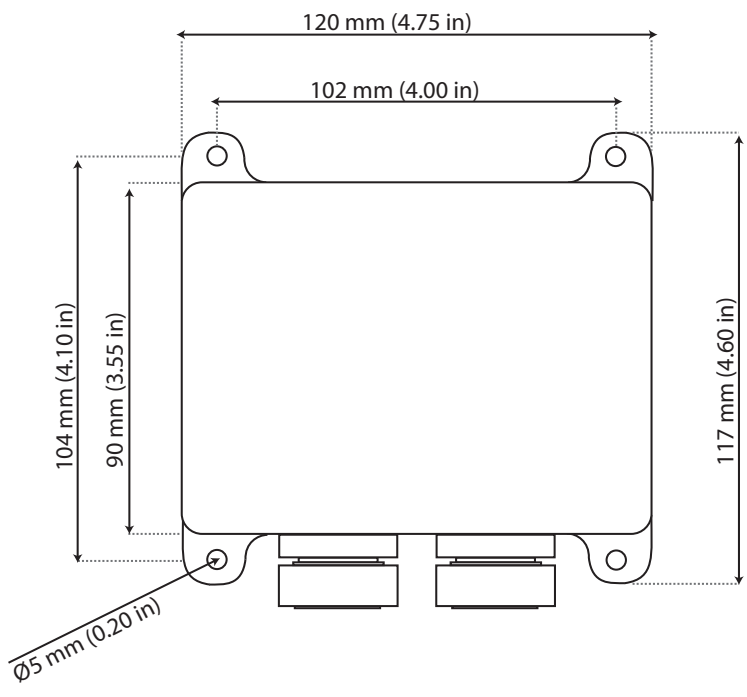

---

## CHAPTER 4: INSTALLERS' GUIDE

### RADIO MODE

**NOTE!** The radio mode is determined by the selected Operating mode. To establish a radio link between the transmitter and receiver, both units need to be set to the same radio mode.

This receiver is set to continuous radio mode by default.

Note that some settings can only be selected when the products are transmitting continuously. These settings are marked with the text: "Only for continuous radio mode".

### LOGOUT

**NOTE!** You cannot activate/deactivate the logout function in the receiver. Contact your representative for assistance.

For this receiver the logout function is activated by default.

For the logout function to work, the receiver must be set to continuous radio mode.

### RELAY FUNCTIONS

This receiver is set to momentary relay functionality by default. The relay is active while you press a button on the transmitter: when the button is released the relay deactivates. Setting a relay to latching means that the relay becomes active when you press a button and remains active until the button is pressed again.

#### Momentary or latching relay functions

**NOTE!** The settings options depend on the selected Operating mode. If Operating mode 0 is selected, you cannot apply these settings. Contact your representative for assistance.

**NOTE!** Before choosing these settings, make sure that the stop relays are deactivated!

1. Press the Function button twice.  
LED 9 lights (yellow). The relay LEDs light (red).
2. Press the Select button to enter the settings menu for switching relay functionality.  
The relay LEDs flash (red) to indicate that a latching or momentary functionality can be set to the corresponding relays.
3. Press the Function button to set latching or momentary functionality:  
LED 9 (yellow) off = momentary relay functionality  
LED 9 (yellow) on = latching relay functionality
4. Press the Select button to move to the next available relay.  
After moving through all available relays, the receiver exits the settings menu and restarts.

---

## OPERATING MODES

### Select Operating mode

NOTE! Go to the Operating modes pages to see the Operating modes available when transmitting in continuous/discontinuous radio mode. Operating modes do not work for both radio modes.

1. Press the Function button 4 times.  
LED 10 lights (orange).
2. Press the Select button to see the Operating mode in use.  
The relay LEDs light (red) according to the table below, LED 10 flashes (orange).

NOTE! The first relay in the row is relay 5. The second relay is relay 1.

When relay LED no. lights...	the selected Operating mode is...
0	0*
1	1 (default)
2	2
1+2	3
3	4
1+3	5
ALL	255*

3. Press the Function button to move to the next available Operating mode.
4. Press the Select button to select Operating mode.  
The receiver exits the Operating mode menu and restarts.

Example: Operating mode 2 is selected because relay LED 2 lights. By pressing the Function button once, you move to Operating mode 3 and LEDs 1+2 light. If you want to move to Operating mode 4, press the Function button once more and LED 3 lights.

\*Operating modes reserved for specific customer applications. Contact your representative for assistance.

# OPERATING MODE 1

**NOTE!** Only for continuous radio mode.

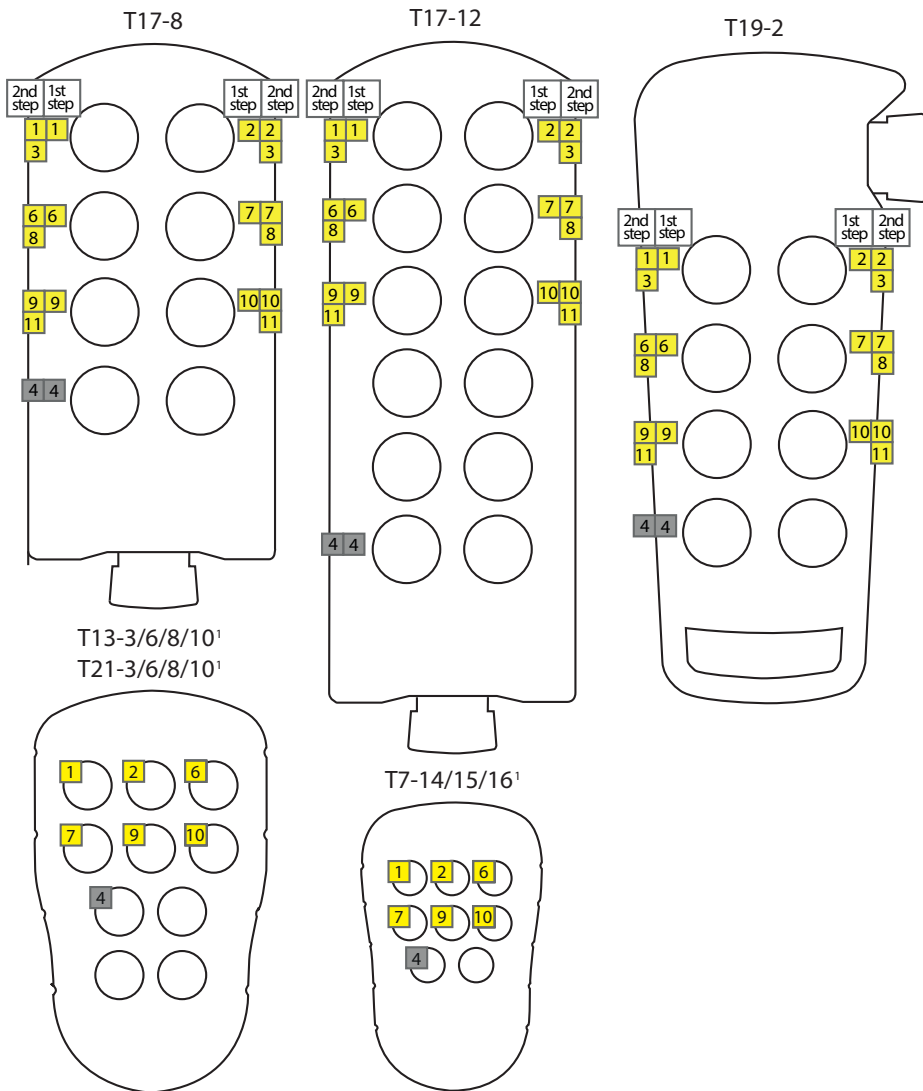

■ Button functions  
 ■ Direction functions

On relays	Relay 5 is active when the radio link is up
Work relays	–
Load select relays	–
Programmable relay functions	Relay 4 can be set to latching
Interlocking	Between button pairs: 1–2, 3–4, 5–6
Radio mode	Continuous
Zero position check	Active for all functions

<sup>1</sup>ON button must be set in order to work with this Operating mode.

The button used as OFF button can not be used to activate a function relay.

This Operating mode supports Load select mode. See the transmitter installation instructions for available Load select modes.

## OPERATING MODE 2

NOTE! Only for continuous radio mode.

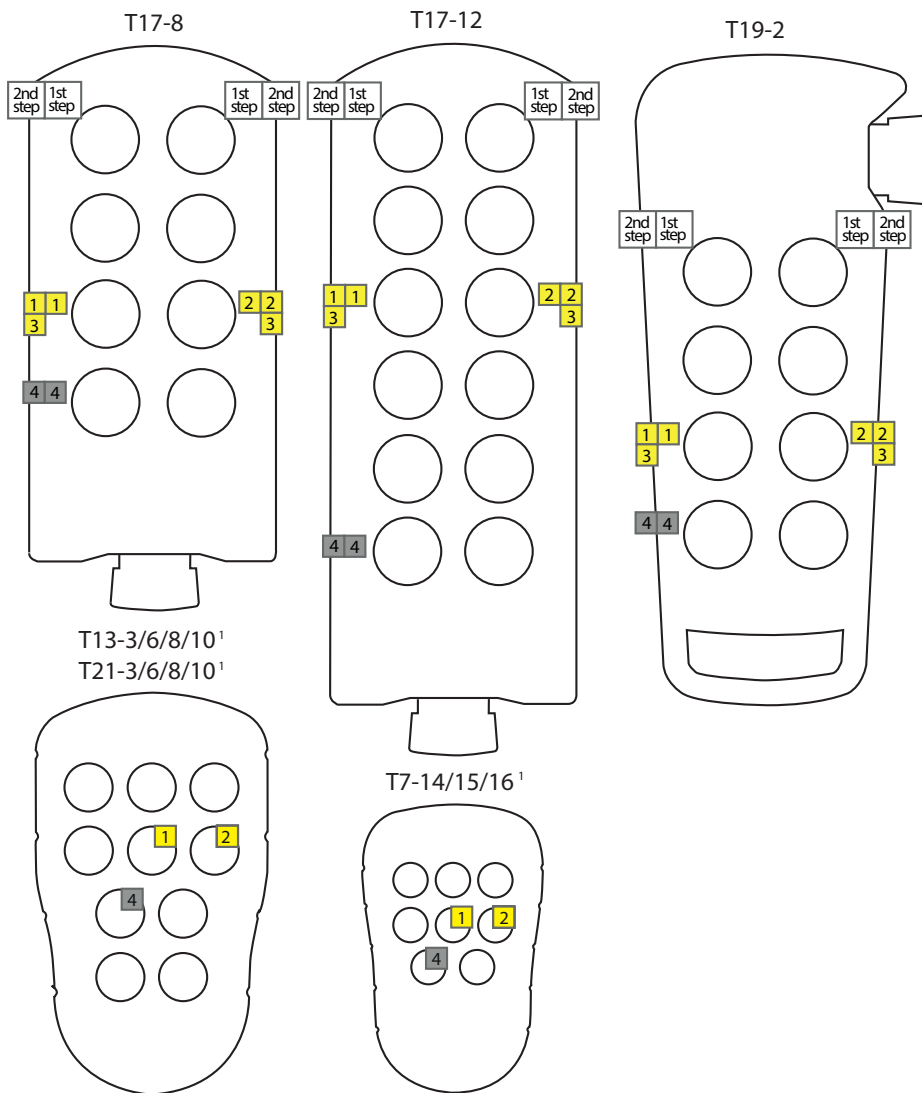

■ Button functions  
 ■ Direction functions

On relays	Relay 5 is active when the radio link is up
Work relays	–
Load select relays	–
Programmable relay functions	Relay 4 can be set to latching
Interlocking	Between button pairs: 5–6
Radio mode	Continuous
Zero position check	Active for all functions

<sup>1</sup>ON button must be set in order to work with this Operating mode.

The button used as OFF button can not be used to activate a function relay.

This Operating mode supports Load select mode. See the transmitter installation instructions for available Load select modes.

## OPERATING MODE 3

**NOTE!** Only for continuous radio mode.

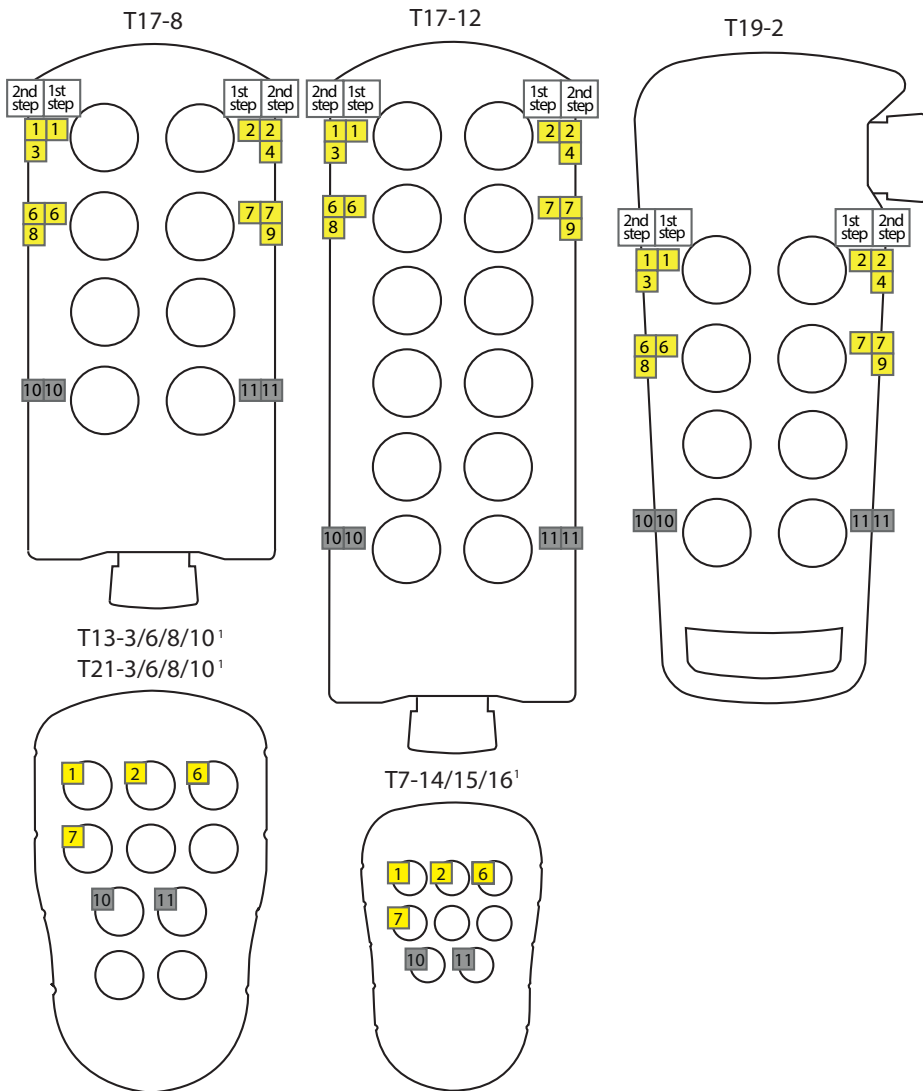

■ Button functions  
 ■ Direction functions

On relays	Relay 5 is active when the radio link is up
Work relays	–
Load select relays	–
Programmable relay functions	Relays 10–11 can be set to latching
Interlocking	Between button pairs: 1–2, 3–4
Radio mode	Continuous
Zero position check	Active for all functions

<sup>1</sup>ON button must be set in order to work with this Operating mode.

The button used as OFF button can not be used to activate a function relay.

This Operating mode supports Load select mode. See the transmitter installation instructions for available Load select modes.

## OPERATING MODE 4

NOTE! Only for continuous radio mode.

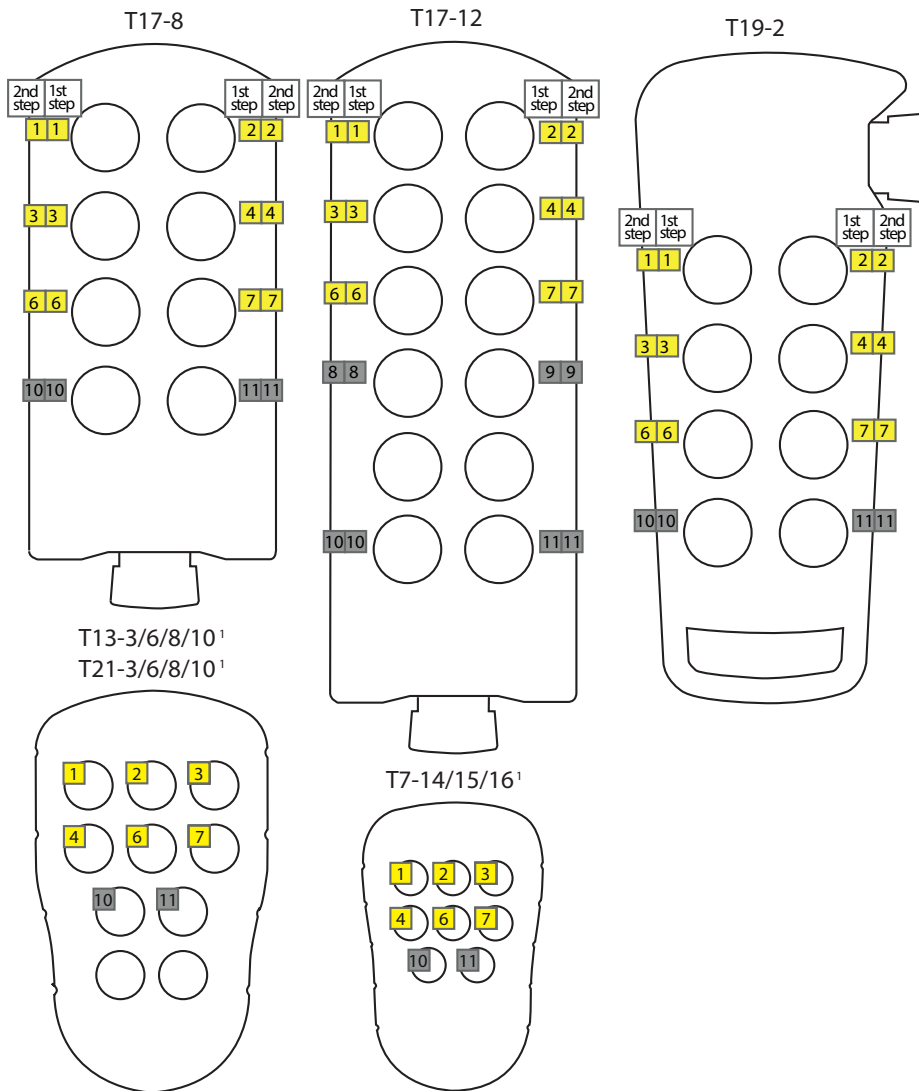

- Button functions
- Direction functions

On relays	Relay 5 is active when the radio link is up
Work relays	–
Load select relays	–
Programmable relay functions	Relays 10–11 can be set to latching
Interlocking	Between button pairs: 1–2, 3–4, 5–6
Radio mode	Continuous
Zero position check	Active for all functions

'ON button must be set in order to work with this Operating mode.

The button used as OFF button can not be used to activate a function relay.

This Operating mode supports Load select mode. See the transmitter installation instructions for available Load select modes.



## OPERATING MODE 5

NOTE! Only for discontinuous radio mode.

WARNING! Discontinuous radio mode cancels the PLd safety classified stop function.

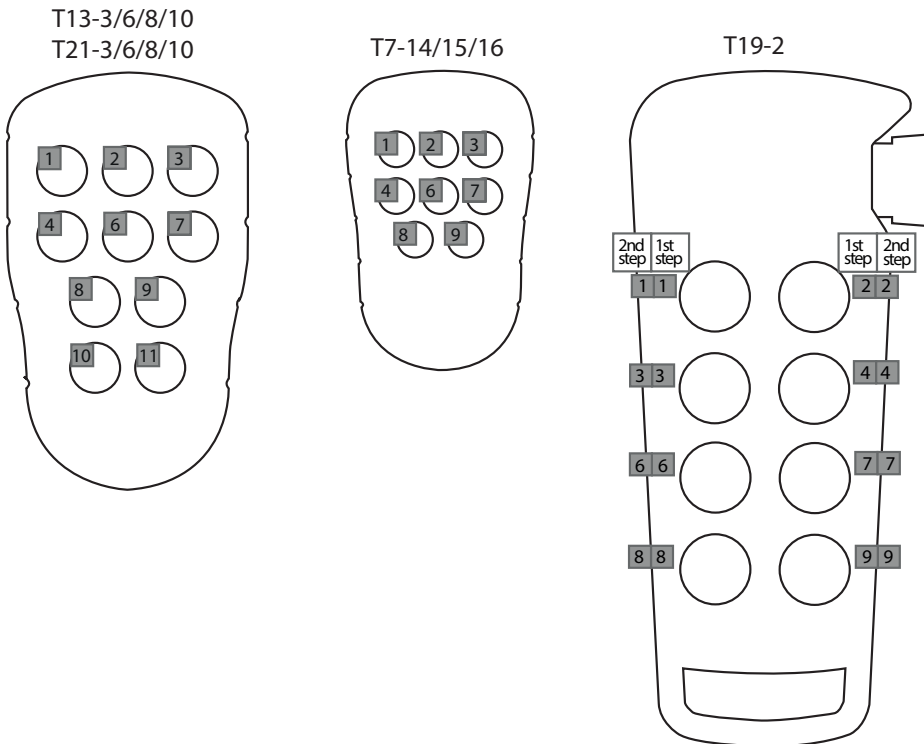

### ■ Button functions

On relays	–
Work relays	Relay 5 is active when the relay 1–4 or 6–11 is active
Load select relays	–
Programmable relay functions	Relay 1–4, 6–11 can be set to latching
Interlocking	–
Radio mode	Discontinuous
Zero position check	–

---

## CHAPTER 5: GUARANTEE, SERVICE, REPAIRS AND MAINTENANCE

Tele Radio AB products are covered by a guarantee/warranty against material, construction and manufacturing faults. During the guarantee/warranty period, Tele Radio AB may replace the product or faulty parts. Work under guarantee/warranty must be carried out by Tele Radio AB or by an authorized service centre specified by Tele Radio AB.

The following are not covered by the guarantee/warranty:

- Faults resulting from normal wear and tear
- Parts of a consumable nature
- Products that have been subject to unauthorized modifications
- Faults resulting from incorrect installation and use
- Damp and water damage

Maintenance:

- Repairs and maintenance must be carried out by qualified personnel
- Use spare parts from Tele Radio AB only
- Contact your representative if you require service or other assistance
- Keep the product in a dry, clean place
- Keep contacts and antennas clean
- Wipe off dust using a slightly damp, clean cloth

**WARNING! Never use cleaning solutions or high-pressure water.**

---

## CHAPTER 6: REGULATORY INFORMATION

### CE MARKING

This product is in compliance with the essential requirements of directive 1995/5/EC of the European Parliament and of the Council. Latest version of the Declaration of Conformity can be downloaded from the Tele Radio AB website.

---

## CHAPTER 7: FREQUENT TERMS

Configuration ID	Numerical code stored in both the transmitter and receiver unit. The receiver unit can only be controlled by a transmitter with the correct configuration ID.
Continuous radio mode	When in continuous radio mode the transmitter unit transmits continuously when it is switched on.
Custom ID	Numerical code stored in the transmitter unit, used to replace the unique ID code. One or several transmitter units can be configured with the same custom ID and the receiver will recognise them all as the same transmitter unit.
Discontinuous radio mode	When in discontinuous radio mode the transmitter unit transmits whenever it is switched on and a button is pressed. The transmission is interrupted when all buttons are released.
Function relay	Standard relay, controlled by the buttons on the transmitter unit.
Interlocking	Prevents a component from functioning when another component is functioning or operating in a particular way.
Latching relay functionality	The relay becomes active every time you press a button and remains active until the button is pressed again.
Load select mode	One or more Load select modes are stored in the transmitter unit. Activating a specific Load select mode results in a group of preselected relays on the receiver unit, which may be controlled from the transmitter unit.
Momentary relay functionality	The relay will only be active while a button is pressed on the transmitter. When the button is released, the relay will no longer be active.
On relay	Relay that is active when the receiver unit is operating and a radio link is established, regardless of whether any other relays are active.
Operating mode	One or more operating modes are stored in the receiver unit. Each operating mode describes which relays on the receiver unit are controlled when specific buttons on the transmitter unit are pressed.
Replace ID	Numerical code used to identify the transmitter during the Replace procedure.
Stop relay	Safety related relay controlled by the stop button on the receiver. Intended to interrupt the power supply to a safety application controlled by the receiver unit.
Work relay	Relay that is active when any other specified relay(s) on the receiver unit is/are active.
Zero position check	Security function ensuring that potentially active buttons/joysticks upon start up or lost/found radio links must be in the zero position before the system can be used to avoid unplanned movements of the controlled object.

---

(This page has intentionally been left blank)

**INSTRUKTIONER**  
INSTRUKSJONER  
INSTRUCCIONES  
ANLEITUNG  
**JUHISED**  
INSTRUCTIES  
说明



This installation instruction is subject to change without prior notice.  
Download the latest installation instruction from [www.tele-radio.com](http://www.tele-radio.com)