

BALL BEARING TROLLEY

SERVICE INSTRUCTIONS AND PARTS LIST

MODELS CBTP AND CBTG

1/4 THRU 5 TON

This trolley is a relatively simple mechanism requiring comparatively little care, maintenance, inspection and lubrication. The following information is provided to assist in installing and maintaining this equipment.

INSTALLATION

Sliding the trolley over the open end of the runway beam is the simplest way to install this unit. If an open beam end is not available, one side plate can be removed and the unit can be reassembled on the beam. Always verify the trolley is adjusted properly to fit the beam. See the adjustment instructions below and the diagram to the right. Always run the unit along the entire length of the runway beam to verify proper operation and clearances.

GENERAL MAINTENANCE

Thorough inspection is recommended at regular intervals. The frequency of inspection must be determined by the user, since application factors such as duty cycle and ambient conditions will dictate the maintenance requirements of the unit. When inspections are made, the entire trolley should be inspected for wear, or for damage such as may be sustained through severe overloading or impact with other objects. Replace all damaged parts immediately. Check trolley motion along the runway beam, to verify proper operation.

LUBRICATING THE TROLLEY

1/4 thru 5 ton trolleys are built with sealed, life-time lubricated precision ball bearings that should require no further lubrication. Periodic lubrication of the geared trolley drive shaft support block is recommended. A small amount of medium grade motor oil should be applied in the oil hole provided in the top of the drive shaft support block.

ADJUSTMENT INSTRUCTIONS

The beam flange width plus approximately 1/16" running clearance on each side of the flange is the correct trolley setting with the total beam to wheel flange clearance not to exceed 3/16". Move the spacing washers to the inside or outside of the side plates as required. After adjustment, tighten the trolley pin nuts and the locking nuts securely.

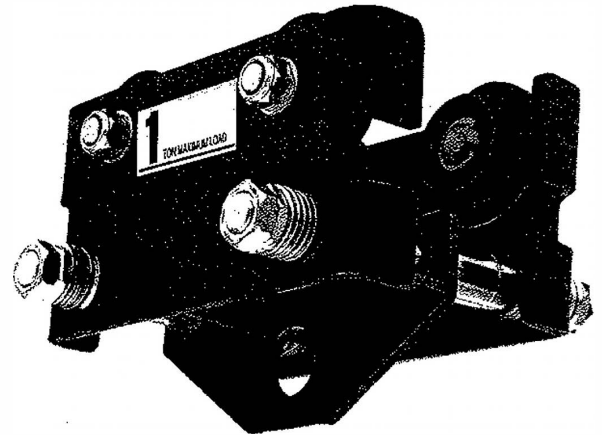

CAUTION:

THE EQUIPMENT ILLUSTRATED AND DESCRIBED IN THIS BULLETIN IS DESIGNED FOR MANUAL OPERATION ONLY AND IS NOT TO BE POWER DRIVEN, NOR IS IT SUITABLE FOR TRANSPORTING PERSONS!

ADJUSTMENT ILLUSTRATION

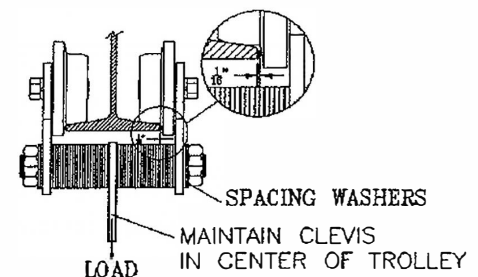

WARNING

-- TO AVOID INJURY --

- DO NOT OPERATE IF TOTAL BEAM TO WHEEL FLANGE CLEARANCE EXCEEDS 3/16 INCH
- DO NOT USE FOR SUPPORTING MORE THAN RATED LOAD
- DO NOT OPERATE DAMAGED OR MALFUNCTIONING TROLLEY
- DO NOT USE FOR LIFTING/SUPPORT OF PEOPLE OR LOADS OVER PEOPLE
- DO INSTALL ONLY ON SUPPORT BEAM FOR WHICH TROLLEY WAS INTENDED
- DO NOT OPERATE UNLESS UNIT IS CENTERED OVER THE LOAD
- DO NOT REMOVE OR OBSCURE THIS WARNING TAG

-- IMPORTANT --

READ ASME B30.16 AND B30.11 SAFETY CODES FOR OVERHEAD HOIST AND APPROPRIATE CM INSTALLATION, MAINTENANCE AND PARTS INSTRUCTIONS BEFORE INSTALLING TROLLEY.

1/4 THRU 5 TON CAPACITY TROLLEY PARTS LIST

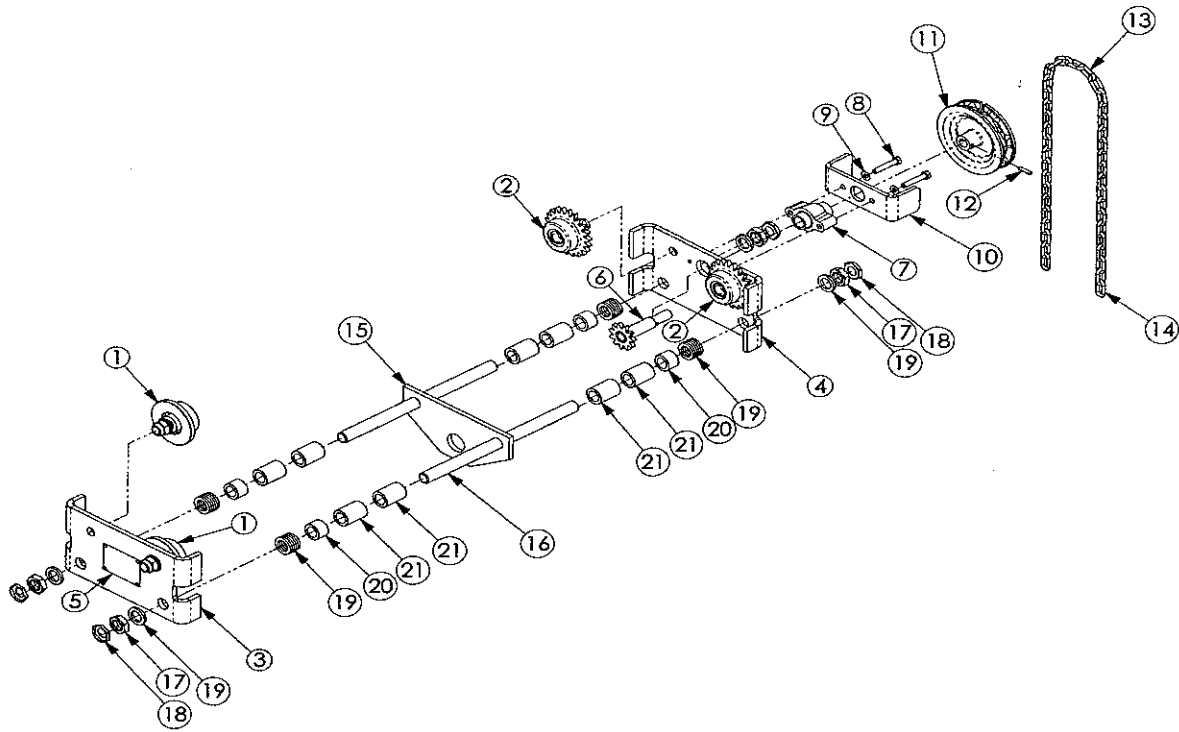

ITEM NO	ITEM DESCRIPTION	1/4 AND 1/2 TON		1 TON		1-1/2 AND 2 TON		3 TON		5 TON	
		PART NO	QTY	PART NO	QTY	PART NO	QTY	PART NO	QTY	PART NO	QTY
1	Plain Wheel Assembly	00508207	4	00508207	4(2)	00508208	4(2)	00508209	4(2)	00508210	4(2)
2	Geared Wheel Assembly	n/a	0	00508211	0(2)	00508212	0(2)	00508213	0(2)	00508214	0(2)
3	Plain Side Plate	00550115	2	00550117	2(1)	00550118	2(1)	00550237	2(1)	00550239	2(1)
4	Geared Side Plate	n/a	0	00550047	0(1)	00550242	0(1)	00550243	0(1)	00550244	0(1)
5	1/4 Ton Nameplate	00550245A	1	n/a	0	n/a	0	n/a	0	n/a	0
5	1/2 Ton Nameplate	00550245B	1	n/a	0	n/a	0	n/a	0	n/a	0
5	1 Ton Nameplate	n/a	0	00550245C	1	n/a	0	n/a	0	n/a	0
5	1-1/2 Ton Nameplate	n/a	0	n/a	0	00550245D	1	n/a	0	n/a	0
5	2 Ton Nameplate	n/a	0	n/a	0	00550245E	1	n/a	0	n/a	0
5	3 Ton Nameplate	n/a	0	n/a	0	n/a	0	00550245F	1	n/a	0
5	5 Ton Nameplate	n/a	0	n/a	0	n/a	0	n/a	0	00550245G	1
6	Drive Pinion and Shaft	n/a	0	00557206	0(1)	00557206	0(1)	00557206	0(1)	00557206	0(1)
7	Drive Shaft Bearing Block	n/a	0	00557204	0(1)	00557200	0(1)	00557313	0(1)	00508229	0(1)
8	Bearing Block Bolt	n/a	0	09101052	0(2)	09101050	0(2)	09101050	0(2)	09101050	0(2)
9	Bearing Block Bolt Washer	n/a	0	09122016	0(2)	09122016	0(2)	09122016	0(2)	09122016	0(2)
10	Hand Chain Guard	n/a	0	00557314	0(1)	00557314	0(1)	00508231	0(1)	00558062	0(1)
11	Hand Chain Wheel	n/a	0	00557304	0(1)	00557304	0(1)	00508230	0(1)	00558061	0(1)
12	Handwheel Retaining Pin	n/a	0	09134052	0(1)	09134052	0(1)	09134052	0(1)	09134052	0(1)
13	Hand Chain(specify length)	n/a	0	04307654	0(1)	04307654	0(1)	04307654	0(1)	04307654	0(1)
14	Hand Chain Connecting Link	n/a	0	00404733	0(1)	00404733	0(1)	00404733	0(1)	00404733	0(1)
15	Clevis	00550053	1	00550051	1	00550059	1	00550073	1	00550079	1
16	Trolley Pin	00550071	2	00550048	2	00550056	2	00550077	2	00550082	2
17	Trolley Pin Nut	09115070	4	09115001	4	09115101	4	09115159	4	09115161	4
18	Trolley Pin Lock Nut	09115030	4	09115536	4	09115157	4	09115154	4	09115162	4
19	Trolley Pin Washer	09121227	28	09121225	28	09121226	28	00550085	24	00550084	24
20	Short Spacer	00550069	4	00550050	4	00550058	4	00550076	4	00550081	4
21	Long Spacer	00550070	8	00550049	8	00550057	8	00550075	8	00550080	8

NOTE: QUANTITIES SHOWN FOR PLAIN UNITS. GEARED QUANTITIES ARE SHOWN IN BRACKETS ().
 1/4 TON AND 1/2 TON TROLLEY AVAILABLE IN PLAIN STYLE ONLY.

COFFING HOIST, P.O. BOX 449, WADESBORO, NC 28170 PHONE: (800) 477-5003
 CM HOIST, 140 JOHN JAMES AUDUBON PARKWAY, AMHERST, NY 14228 PHONE: (800) 888-0985
 YALE/LIFT-TECH, P.O. BOX 769, MUSKEGON, MI 49443 PHONE: (800) 742-9269

Trolley Type: STP/STG 1/2-5 Metric Ton

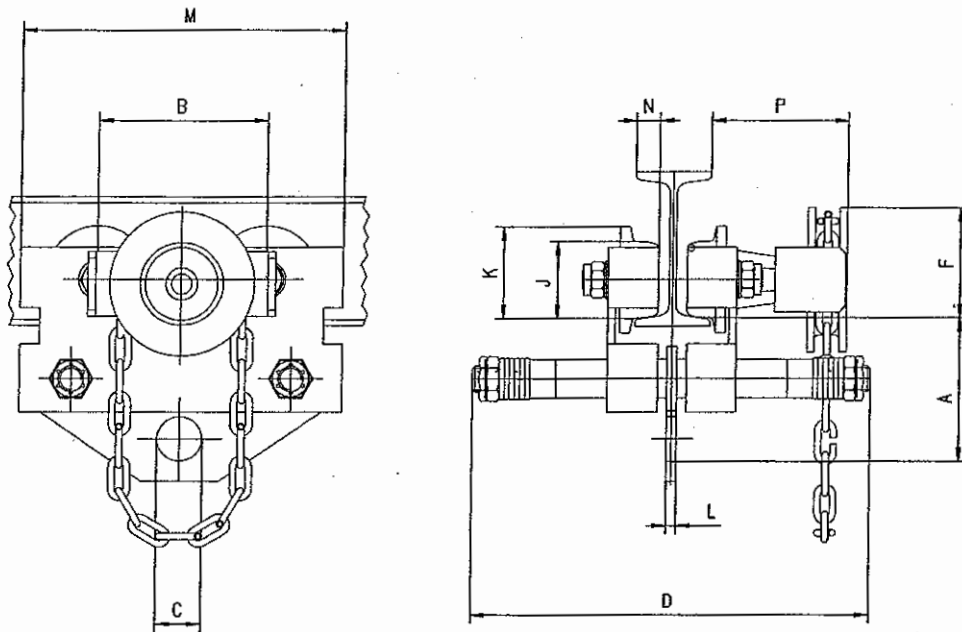

Technical Data STP

Metric Capacity	ton	1/2	1	2	3	5
Beam Width Range	in.	2.0-8.7	2.3-8.7	2.3-8.7	3.0-8.7	3.5-8.7
Max. Flg. Thickness	in.	.75	.75	.75	1.0	1.0
Min. Radius Curve	in.	27	36	45	55	70
Unit Weight	lb.	19	26	46	86	130

Technical Data STG

Metric Capacity	ton	-	1	2	3	5
Beam Width Range	in.	-	2.3-8.7	2.3-8.7	3.0-8.7	3.5-8.7
Max. Flg. Thickness	in.	-	.75	.75	1.0	1.0
Min. Radius Curve	in.	-	36	45	55	70
Unit Weight*	lb.	-	36	55	100	144

* (includes 15 ft of handchain)

Dimensions in inches

Capacity Metric Ton	A	B	C	D	F STG	J	K	K STG	L	M	N	P STG
1/2	3.94	3.54	1.18	11.81	-	2.36	2.83	-	.31	7.56	.71	-
1	4.33	5.12	1.38	12.20	3.60	2.36	2.83	3.03	.31	9.84	.71	4.33
2	5.12	5.91	1.89	12.60	3.56	3.15	3.78	3.86	.47	11.81	.79	4.33
3	6.18	7.09	2.36	13.39	4.23	4.41	5.20	5.24	.55	14.57	1.14	4.33
5	7.09	8.23	2.76	13.78	5.89	4.92	5.63	5.87	.79	17.32	1.26	4.33