

Operating, Maintenance & Parts Manual

EMW Series
500 lbs Capacity

Electric Wire Rope



Follow all instructions and warnings for inspecting, maintaining and operating this hoist.

The use of any hoist presents some risk of personal injury or property damage. That risk is greatly increased if proper instructions and warnings are not followed.

Forward this manual to the hoist operator. Failure to operate the equipment as directed in the manual may cause injury.

Should you have any questions regarding this product, please call Coffing Hoists at (800) 477-5003.

Before using the hoist, fill in the information below:

Model No. _____
Serial No. _____
Purchase Date _____

TABLE OF CONTENTS

Safety Precautions2
Hoist Specifications3
Application Information3
Safety Information3
Installation4
Operation4
Maintenance4
Trouble Shooting5
Wiring Diagrams7
Replacement Parts List7
WarrantyBack Cover

COFFING HOISTS

SAFETY PRECAUTIONS

Each Coffing EMW series wire rope hoist is built in accordance with the specifications contained herein and at the time of manufacture complies with our interpretation of applicable sections of *American Society of Mechanical Engineers Code (ASME) B30.16 "Overhead Hoists," the National Electrical Code (ANSI/NFPA 70) and the Occupational Safety and Health Act (OSHA). Since OSHA states the National Electrical Code applies to all electric hoists, installers are required to provide current overload protection and grounding on the branch circuit section in keeping with the code. Check each installation for compliance with the application, operation and maintenance sections of these articles.

*Copies of this Standard can be obtained from ASME Order Department, 22 Law Drive, Box 2300, Fairfield, NJ 07007-2300, U.S.A.

WARNING

Improper operation of a hoist can create a potentially hazardous situation which, if not avoided, could result in death or serious injury. To avoid such a potentially hazardous situation, THE OPERATOR SHALL:

1. **NOT** operate a damaged, malfunctioning or unusually performing hoist.
2. **NOT** operate the hoist until you have thoroughly read and understood the manufacturer's Operating and Maintenance Instructions or Manuals.
3. **NOT** operate a hoist which has been modified without the manufacturer's approval or without certification that it is in conformity with ANSI/ASME B30 volumes.
4. **NOT** lift more than rated load for the hoist.
5. **NOT** use hoist with twisted, kinked, damaged, or worn wire rope.
6. **NOT** use the hoist to lift, support, or transport people.
7. **NOT** lift loads over people.
8. **NOT** operate a hoist unless all persons are and remain clear of the supported load.
9. **NOT** operate unless load is centered under hoist.
10. **NOT** attempt to lengthen the wire rope or repair damaged wire rope.
11. Protect the hoist's wire rope from weld splatter or other damaging contaminants.
12. **NOT** operate hoist when it is restricted from forming a straight line from hook to hook in the direction of loading.
13. **NOT** use wire rope as a sling, or wrap wire rope around load.
14. **NOT** apply the load to the tip of the hook or to the hook latch.
15. **NOT** apply load unless wire rope is properly seated in its groove(s).
16. **NOT** apply load if bearing prevents equal loading on all load supporting ropes.
17. **NOT** operate beyond the limits of the wire rope.
18. **NOT** leave load supported by the hoist unattended unless specific precautions have been taken.

19. **NOT** allow the wire rope or hook to be used as an electrical or welding ground.
20. **NOT** allow the wire rope or hook to be touched by a live welding electrode.
21. **NOT** remove or obscure the warnings on the hoist.
22. **NOT** operate a hoist on which the safety placards or decals are missing or illegible.
23. **NOT** operate a hoist unless it has been securely attached to a suitable support.
24. **NOT** operate a hoist unless load slings or other approved single attachments are properly sized and seated in the hook saddle.
25. Take up slack carefully - make sure load is balanced and load holding action is secure before continuing.
26. Shut down a hoist that malfunctions or performs unusually and report such malfunction.
27. Make sure hoist limit switches function properly.
28. Warn personnel of an approaching load.

CAUTION

Improper operation of a hoist can create a potentially hazardous situation which, if not avoided, could result in minor or moderate injury. To avoid such a potentially hazardous situation, THE OPERATOR SHALL:

1. Maintain firm footing or be otherwise secured when operating the hoist.
2. Check brake function by tensioning the hoist prior to each lift operation.
3. Use hook latches. Latches are to retain slings, chains, etc. under slack conditions only.
4. Make sure the hook latches are closed and not supporting any parts of the load.
5. Make sure the load is free to move and will clear all obstructions.
6. Avoid swinging the load or hook.
7. Make sure hook travel is in the same direction as shown on the controls.
8. Inspect the hoist regularly, replace damaged or worn parts, and keep appropriate records of maintenance.
9. Use the hoist manufacturer's recommended parts when repairing the unit.
10. Lubricate wire rope per hoist manufacturer's recommendations.
11. **NOT** use the hoist load limiting or warning device to measure load.
12. **NOT** use limit switches as routine operating stops. They are emergency devices only.
13. **NOT** allow your attention to be diverted from operating the hoist.
14. **NOT** allow the hoist to be subjected to sharp contact with other hoists, structures, or objects through misuse.
15. **NOT** adjust or repair the hoist unless qualified to perform such adjustments or repairs.



HOIST SPECIFICATIONS

Coffing EMW series electric hoists are compact wire rope hoists designed for a variety of light duty applications. The EMW is constructed of lightweight aluminum housings to provide strength and portability, weighing less than 25 lbs. Other features include; thermally protected motors, swivel top suspension, upper paddle limit switch to regulate load travel, quick acting electromagnetic brake for positive load control and thermal motor protection to prevent overheating. As a standard, hooks are supplied with safety latches.

Coffing EMW series hoists are designed and tested in accordance with the American Society of Mechanical Engineers Code B30.16, "Safety Standard for Overhead Hoists." Coffing EMW series hoists are built in compliance with UL, file number SA 5247. Made in U.S.A.

WARNING

Failure to comply with Safety Precautions outlined throughout this manual can result in serious injuries or death. Before using this hoist, each operator should become thoroughly familiar with all warnings, instructions and recommendations in this manual.

APPLICATION INFORMATION

This hoist is intended for lifting freely suspended (unguided) loads weighing no more than 500 pounds. This hoist is not intended for industrial or production applications requiring continuous operation, it should only be used on an intermittent basis. Coffing Hoists cannot be responsible for applications other than those for which Coffing equipment is recommended. Prior to installation and operation, we caution the user to review his application for abnormal environmental or handling conditions and to observe the applicable recommendations as follows:

ADVERSE ENVIRONMENTAL CONDITIONS

Do not use the hoist in uncovered outdoor locations, areas containing flammable vapors, liquids, gases or any combustible dusts or fibers. Refer to Article 500 of the National Electrical Code. Do not use this hoist in highly corrosive, abrasive or wet environments. Do not use this hoist in applications involving extended exposure to ambient temperatures below -10°F or above 130°F.

LIFTING OF HAZARDOUS LOADS

This hoist is not recommended for use in lifting or transporting hazardous loads or materials which could cause widespread damage if dropped. The lifting of loads which could explode or create chemical or radioactive contamination if dropped requires fail-safe redundant supporting devices which are not incorporated into this hoist.

Table 1 - Basic Specifications

Model No.	Rated Capacity	Power Supply	Lifting Speed (fpm)	Max. Lift (ft)	Horse-power (hp)	Head-room	Duty Cycle Max.	PB Cord Length (in)	Limit Switches	Power Cord Length (in)	Amp Draw	Overall Dia. (in)	Net Wt. (lb)
EMW500C	500	115 volts, 1-Phase 60 Hz	10	10	1/6	14½	10 Minutes per hour	6	Upper Paddle	13	3 amps	4 ⁵ / ₈ H x 6 W x 14½ L	21

LIFTING OF GUIDED LOADS

This hoist is not recommended for use in the lifting of guided loads, including dumbwaiters and elevators. Such applications require additional protective devices which are not incorporated into this hoist. For such applications, refer to the requirements of applicable state and local codes, and the American National Safety Code for elevators, dumbwaiters, escalators and moving walks (ASME A17.1).

SAFETY INFORMATION

1. Follow all local electrical and safety codes, as well as the National Electrical Code (NEC) and the Occupational Safety and Health Act (OSHA) in the United States.
2. Hoist must be securely and adequately grounded.
3. Be careful when touching the exterior of an operating motor; it may be hot enough to be painful or cause injury. With modern motors this condition is normal if operated at rated load and voltage (modern motors are built to operate at higher temperatures).
4. Protect the power cable and control cable from coming in contact with sharp objects.
5. Do not kink power cable and control cable and never allow the cable to come in contact with oil, grease, hot surfaces, or chemicals.
6. Make certain that the power source conforms to the requirements of your equipment.
7. Inspect the unit daily before operating hoist.
8. Cluttered areas and benches invite accidents.
9. The operator should not engage in any practice which will divert his attention while operating the hoist.
10. Before using the hoist, the operator should be certain that all personnel are clear.
11. Do not operate hoist with loads exceeding its rated capacity.
12. Supporting frames or beams used as a hoist hanger must have a greater load capacity than the hoist.
13. Do not attempt to operate hoist beyond normal maximum lift range.
14. Align hoist for a straight line pull. Avoid side pull or end pull.
15. Do not operate hoist with twisted or damaged wire rope.
16. Do not operate a damaged or malfunctioning hoist until necessary adjustments or repairs have been made.
17. Do not use hoist to lift people or to carry loads over people.
18. Do not leave a load suspended in the air unattended.
19. Always remove load before making repairs.
20. Do not remove or obscure capacity or warning decals.

INSTALLATION

1. Before installing the hoist, check the following:
 - a. Make sure all supporting structures and attaching devices are strong enough to hold your intended loads. If in doubt, consult a qualified structural engineer.
 - b. This hoist is equipped with a 3-prong, grounding-type plug to minimize shock hazards. It must be plugged into a properly installed and grounded receptacle to maintain this protection.
 - c. This hoist is intended for use on a 115 volt, single-phase, 60 Hz power supply. The power supply should be plus or minus 10% of 115 volts.
 - d. Installation area must provide operating conditions for the operator including sufficient room for the operator and other personnel to stand clear of the load at all times.
 - e. Make sure that the hook latch closes after hanging the hoist.

WARNING

Always disconnect power source before working on or near a hoist or its connected load. If the power disconnect point is out of sight, lock it in the open position and tag to prevent unexpected application of power.

2. Before operating the hoist, be sure to observe the following:
 - a. ALWAYS DISCONNECT HOIST FROM POWER SUPPLY before removing electrical cover or when making any electrical connection in the hoist or pushbutton station.
 - b. **Limit Switch Operation.** Before placing the hoist in operation, check for proper upper limit switch operation. Push the "UP" button, and while the hook is moving upward, raise the limit switch paddle (Figure 2, Item 35). The hook should stop immediately. Do not operate the hoist if the limit switch is not operating properly.
 - c. **Brake Operation.** NOTE: Run the hoist with a light load a few times before lifting the rated load. After lifting a light load a few times, test the hoist by lifting the rated load. Check for load hook drift with rated load on the hook. If hook does not stop within one to two inches when pushbutton is released, it may be necessary to replace the brake assembly.

OPERATION

This hoist is designed for safe operation within the limits of its rated capacity. It is controlled by the "UP" and "DOWN" buttons of the pushbutton station. Although the Coffing EMW is built with many features to ensure safety, it is a requirement that a hoist operator understands safe lifting practices. The following points must be observed.

1. Do not overload the hoist.
2. Align hoist directly over load. Do not make extreme side pulls with the hoist.
3. Operate the hoist only in a hanging position with adequate support.
4. Do not "sling" the load hook and wire rope around the load. Use an approved sling.

5. Be sure there are no twists or kinks in the wire rope as it travels into the hoist housing.
6. Lift the load just clear of its supports and stop the hoist to check for proper brake action.
7. Do not stand beneath a load! Do not move a load in such a manner as to endanger personnel.
8. Don't lower into areas where visibility is obscured unless someone else is guiding the operation.
9. Use common sense at all times when operating a hoist.
10. Do not run hook down so that fewer than two wraps of cable remain on drum.
11. Lift and lower the load smoothly, avoiding jogging of the controls or quick reversals.
12. Do not reverse wind cable on drum. If hoist runs in direction opposite that indicated on pushbutton, cable may be reverse wound. If this situation occurs, cease using hoist immediately. Rewind cable in proper direction and inspect hoist for damage.
13. Do not operate damaged or malfunctioning hoist.
14. The limit switch is an emergency protective device. Do not use the limit switch to stop the hoist in normal operation.

MAINTENANCE

INSPECTIONS

A planned inspection routine should be established for this hoist based upon frequency of use, severity of use, and environmental conditions (Reference ASME Standard B30.16). All inspections should be performed or overseen by a designated inspector. Special inspections should be made following any significant repairs and if the hoist is used more than 40 hours per week, under adverse environmental conditions or any operating occurrence leading one to suspect that the hoist's capability may have been impaired.

1. **Daily Inspection.** Inspect the following items daily before operating the hoist.
 - a. Check pushbutton station, brake, and limit switch for proper operation (See INSTALLATION, 2-b & 2-c).
 - b. Check hooks for deformation, cracks, or chemical damage. Hooks having more than 1" throat opening should be replaced, (See Figure 1, page 5).
 - c. Check for bent or otherwise damaged hook latches.
 - d. Check wire rope for wear, broken wires, kinks or twists.
 - e. Check pushbutton cord and power cord for cuts or damage.
2. **Quarterly Inspection.** Inspect the following items at 90-day intervals.
 - a. Check all items under daily inspection.
 - b. Check for loose bolts, screws and nuts.
 - c. Inspect for worn, corroded, cracked or distorted parts.
 - d. Check electrical parts, limit switch and pushbutton station.
3. **Annual Inspection.** Inspect the following items annually.
 - a. Check all items under daily and quarterly inspection.
 - b. Check hooks for cracks by means of a magnetic particle test or other crack detecting test.



HOOKS

Refer to Figure 1.

1. Inspect hooks once daily for cracking, extreme wear or spreading. Replace hooks showing any of these signs. If the throat openings are spread wider than the maximum permissible 15% increase listed here, the hooks have been overstressed and must be replaced. Any hook that is bent or twisted more than 10 degrees from the plane of an unbent hook must also be replaced.

Normal "X"	Reject "X"
29/32"	1 1/16"

Figure 1 — Hook Inspection



2. The hook latches should be inspected to ensure that they close the hook throat opening in a secure manner when a load is applied. On the top hook, the hook collar should be fully restrained by the retaining pin.

WIRE ROPE

Refer to Figure 2.

To remove the wire rope, loosen the setscrew (49). Remove worn cable assembly (17) by pulling the cable from the drum (4), through the cable guide (32) and the sheave (6), and through the top of the suspension frame (1) after removing the plug (47). NOTE: The bottom block (5) should be disassembled by removing the two screws (44) for the installation of the new cable.

To install the new cable, insert the plain end of the cable assembly through the opening in the suspension frame (1) and pull the cable through the frame until swaged ball is seated in the frame. Replace the plug (47) in top of the frame. Reeve the cable around the sheave (6) and assemble the bottom block (5) with the two screws (44). Position the drum as shown in Figure 2 and push the cable through the guide (32) and through the top opening in the drum and back through the bottom opening in the drum. While holding the cable in place, tighten the setscrew (49) to 25 in. lbs. torque.

LUBRICATION

CAUTION

Keep brake surface and brake lining free of grease.

Proper lubrication is necessary for a long and relatively trouble-free hoist operation.

Wire Rope

Wipe clean with a clean cloth periodically and apply a light coat of oil.

Drum

Apply a small amount of grease to drum shaft bearings (See Figure 2, Ref. No. 39).

Gears

The gear housing is adequately lubricated at assembly with 1/3 pound of NLGI #1 grease. If relubrication becomes necessary, use approximately 3/4 cup of light, semi-fluid grease.

Idler Shaft

Apply a small amount of grease to the bore of the idler sheave (See Figure 2, Ref. No. 6) in the bottom block.

TROUBLE SHOOTING

Always disconnect unit from the power supply system before removing hoist covers or the back cover of control station.

— Probable Cause —

— Remedy —

Hoist cuts off after several minutes of operation, but will run again after several minutes	Thermal protector opening due to excessive duty. Reduce duty cycle.
Brake will not hold, load drifts down.	Brake worn out or oil contaminated. Replace brake assembly.
Brake chatters	Check for gap greater than .010". Check rectifier for open or shorted legs.
Hoist runs in wrong direction when pushbutton is operated.	Check drum for reverse-wound cable. If cable is reverse-wound, run cable off of drum and back on in proper direction. Check for damage to cable guide, limit switch and drum area of hoist which may have resulted from reverse winding.

Figure 2 - EMW Exploded View

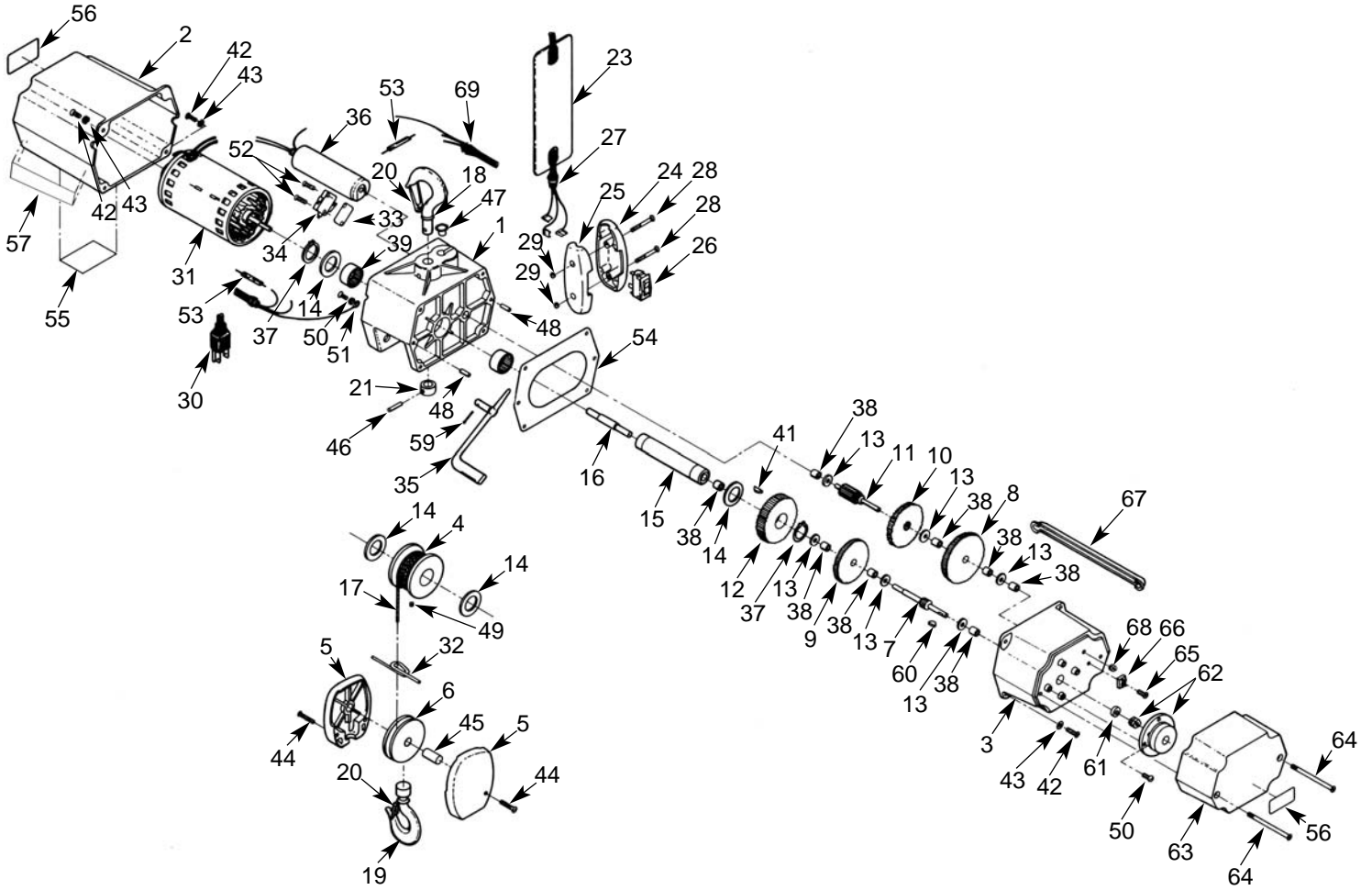

Parts List for EMW Exploded View

Ref No.	Description	Part No.	Qty	Ref No.	Description	Part No.	Qty
1	Suspension Frame	33K4-5	1	35	Paddle (Limit Switch)	24K5B	1
2	Control Cover	36K9-2	1	36	Capacitor	810K1A	1
3	Transmission Cover	35K4	1	37	Retaining Ring	H5543	2
4	Drum	16K4	1	38	Bearing	521K3	8
5	Bottom Block Frame	30K4	2	39	Load Bearing	521K4	2
6	Sheave	28K4	1	40	Woodruff Key (Drum)	H4355	1
7	High Speed Pinion	400K8	1	41	Woodruff Key (Output Gear)	H4356	1
8	High Speed Cluster Gear	406K1	1	42	Screw	H1841P	6
9	Intermediate Cluster Gear	406K2	1	43	Lockwasher	H4061P	6
10	Intermediate Gear	403K10	1	44	Bottom Block Screw	H2743P	2
11	Output Pinion	404K6	1	45	Dowel Pin	H5387	1
12	Output Gear	405K5	1	46	Hook Pin	H5159	1
13	Thrust Washer	255K1	6	47	Plug	H6292	1
14	Thrust Washer	255K2	4	48	Dowel Pin	H5383	2
15	Drum Shaft	132KG6	1	49	Setscrew	S7-121	1
16	Drive Coupling	107K27	1	50	Screw	H2742P	1
17	Cable Assembly, 20 ft.	19K301	1	51	Washer	H4004P	1
18	Hook Assembly (Includes Ref. No. 20)	3M002C01S	1	52	Screw	H2744P	2
19	Hook Assembly (Includes Ref. No. 20)	3M102C01S	1	53	Splice Connector	H5757	3
20	Latch Kit	4X1302	2	54	Gasket	MH560	1
21	Hook Collar	124K2	1	55	Warning Label	MH687	1
22	Pushbutton Station Assembly (Includes Ref. Nos. 23-29)	MH534-1	1	56	Capacity Label	MH675-2	2
23	Warning Label	687K3W	1	57	Coffing Label	912500001	2
24	Pushbutton Enclosure	MH48R	1	58	Nameplate	MH674-10	1
25	Pushbutton Enclosure	MH48L	1	59	Cotter Pin	H5021P	1
26	Rocker Switch	4K1	1	60	Woodruff Key	H4362	1
27	Pushbutton Cord Assembly	936KG9	1	61	Oil Seal	561K29	1
28	Pushbutton Screw	H2967	2	62	Motor Brake Assembly	MH854T	1
29	Pushbutton Flexloc Nut	H3972	2	63	Brake Cover	36K206	1
30	Power Cord Assembly	951KG2	1	64	Screw	H1303	2
31	Motor	861K350A	1	65	Screw	H2752	1
32	Cable Guide	210K4	1	66	Rectifier	840J1	1
33	Insulator	759K1	1	67	Wire Channel	MH270	1
34	Switch (Limit Switch)	815K5	1	68	Pipe Plug	S25-13	1
				69	Brake Harness	940J11	1
				70	Lubricant	H7653	/ lb.

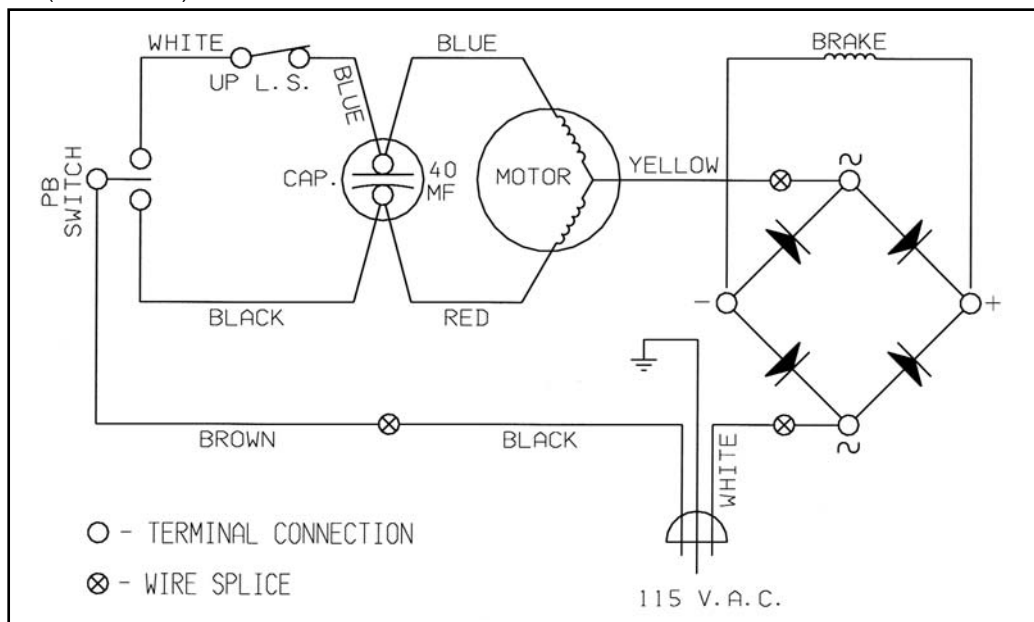

Figure 3 — 981MH4 Wiring Diagram

COFFING[®] WARRANTY



Every hoist is thoroughly inspected and performance tested prior to shipment from the factory. If any properly installed, maintained and operated hoist as outlined in the applicable accompanying Coffing Hoists manual develops a performance problem due to defective materials or workmanship as verified by Coffing Hoists, repair or replacement of the hoist will be made to the original purchaser without charge and the hoist will be returned, transportation prepaid. This warranty does not apply where deterioration is caused by normal wear, abuse, improper or inadequate power supply, improper or inadequate maintenance, eccentric or side loading,

overloading, chemical or abrasive actions, excessive heat, unauthorized modifications or repairs, or use of non-Coffing repair parts. **EXCEPT AS STATED HEREIN, COFFING HOISTS MAKES NO OTHER WARRANTIES, EXPRESS OR IMPLIED, INCLUDING WARRANTIES OF MERCHANTABILITY AND FITNESS FOR A PARTICULAR PURPOSE.**

WARNING

Overloading and Improper Use Can Result In Injury

To Avoid Injury:

- Do not exceed working load limit, load rating, or capacity.
- Do not use to lift people or loads over people.
- Use only alloy chain and attachments for overhead lifting.
- Read and follow all instructions.

COFFING[®] HOISTS

Coffing Hoists • Country Club Road • P.O. Box 779 •
Wadesboro, North Carolina 28170 USA

Tel: 800.477.5003 • **Fax:** 800.374.6853 • 704.694.6829

www.coffinghoists.com