



Read this Owner's Manual thoroughly before operating the equipment. Keep it with the equipment at all times. Replacements are available from Thern, Inc., PO Box 347, Winona, MN 55987, 507-454-2996. www.thern.com

IMPORTANT: Please record product information on page 2. This information is required when calling the factory for service.



Owner's Manual

For Thern Worm Gear Hand Winches

Two-Year Limited Warranty

Please record the following:

Date Purchased: _____

Model No.: _____

Code No.: _____

This information is required when calling the factory for service.

Thern, Inc. warrants its products against defects in material or workmanship for two years from the date of purchase by the original using buyer, or if this date cannot be established, the date the product was sold by Thern, Inc. to the dealer. To make a claim under this warranty, contact the factory for an RGA number. The product must be returned, prepaid, directly to Thern, Inc., 5712 Industrial Park Road, Winona, Minnesota 55987. The following information must accompany the product: the RGA number, the date of purchase, the description of the claimed defect, and a complete explanation of the circumstances involved. If the product is found to be defective, it will be repaired or replaced free of charge, and Thern, Inc. will reimburse the shipping cost within the contiguous USA.

This warranty does not cover any damage due to accident, misuse, abuse, or negligence. Any alteration, repair or modification of the product outside the Thern, Inc. factory shall void this warranty. This warranty does not cover any costs for removal of our product, downtime, or any other incidental or consequential costs or damages resulting from the claimed defects. This warranty does not cover brake discs, wire rope or other wear components, as their life is subject to use conditions which vary between applications.

FACTORY AUTHORIZED REPAIR OR REPLACEMENT AS PROVIDED UNDER THIS WARRANTY IS THE EXCLUSIVE REMEDY TO THE CONSUMER. THERN, INC. SHALL NOT BE LIABLE FOR ANY INCIDENTAL OR CONSEQUENTIAL DAMAGES FOR BREACH OF ANY EXPRESS OR IMPLIED WARRANTY ON THIS PRODUCT. EXCEPT TO THE EXTENT PROHIBITED BY APPLICABLE LAW, ANY IMPLIED WARRANTY OF MERCHANTABILITY OR FITNESS FOR A PARTICULAR PURPOSE ON THIS PRODUCT IS LIMITED IN DURATION TO THE DURATION OF THIS WARRANTY.

Some states do not allow the exclusion or limitation of incidental or consequential damages, or allow limitations on how long an implied warranty lasts, so the above limitation or exclusion may not apply to you. This warranty gives you specific legal rights, and you may also have other rights which vary from state to state.

Note: Thern, Inc. reserves the right to change the design or discontinue the production of any product without prior notice.

About This Manual

The Occupational Safety and Health Act of 1970 states that it is the employer's responsibility to provide a workplace free of hazard. To this end, all equipment should be installed, operated, and maintained in compliance with applicable trade, industrial, federal, state, and local regulations. It is the equipment owner's responsibility to obtain copies of these regulations and to determine the suitability of the equipment to its intended use.

This Owner's Manual, and warning labels attached to the equipment, are to serve as guidelines for hazard-free installation, operation, and maintenance. They should not be understood to prepare you for every possible situation.

The information contained in this manual is applicable only to the Thern Worm Gear Hand Winches. Do not use this manual as a source of information for any other equipment.

The following symbols are used for emphasis throughout this manual:

⚠WARNING

Failure to follow 'WARNING!' instructions may result in equipment damage, property damage, and/or serious personal injury.

⚠CAUTION

Failure to follow 'CAUTION!' instructions may result in equipment damage, property damage, and/or minor personal injury.

Important!

Failure to follow 'important!' instructions may result in poor performance of the equipment.

Suggestions for Safe Operation



⚠️WARNING

DO the following:

Read and comply with the guidelines set forth in this Owner's Manual. Keep this manual, and all labels attached to the winch, readable and with the equipment at all times. Contact Thern, Inc. for replacements.

Check lubrication before use.

Install the wire rope securely to the winch drum.

Keep at least 4 wraps of wire rope wound on the drum at all times, to serve as anchor wraps. With less than 4 wraps on the drum the wire rope could come loose, causing the load to escape.

Keep hands away from the drum, gears, wire rope, and other moving parts of the equipment.

Keep all unnecessary personnel away from winch while in operation. Keep out of the path of the load, and out of the path of a broken wire rope that might snap back and cause injury.

DO NOT do the following:

Do not lift people, or things over people. Do not walk or work under a load or in the line of force of any load.

Do not exceed the load rating of the winch or any other component in the system. To do so could result in failure of the equipment.

Do not use more than one winch to move a load that unless each winch was designed for use in a multiple winch system.

Do not use damaged or malfunctioning equipment. To do so could result in failure of the equipment.

Do not modify the equipment in any way. To do so could cause equipment failure.

Do not wrap the wire rope around the load. This damages the wire rope and could cause the load to escape. Use approved rigging connectors to secure the wire rope to the load.

Do not lift loads or pull loads on an incline unless the winch is equipped with a brake.

Do not divert your attention from the operation. Stay alert to the possibility of accidents, and try to prevent them from happening.

Do not jerk or swing the load. Avoid shock loads by starting and stopping the load smoothly. Shock loads overload the equipment and may cause damage.

Do not leave a suspended load unattended unless specific precautions have been taken to secure the load and keep people away from the winch and out from under the load.

1.1 Installing the Winch

Important!

- Inspect the winch immediately following installation according to the Instructions for Periodic Inspection. This will give you a record of the condition of the winch with which to compare future inspections.
- A qualified professional should inspect or design the foundation to insure that it will provide adequate support.
- Locate the winch so it will be visible during the entire operation.
- Do not weld the winch frame to the foundation or support structure. Welding the frame may void warranty, contact Thern, Inc. Use fasteners as instructed.

⚠WARNING

Do not install the winch in an area defined as hazardous by the National Electric Code, unless installation in such an area has been thoroughly approved.

Do not install the winch near corrosive chemicals, flammable materials, explosives, or other elements that may damage the winch or injure the operator. Adequately protect the winch and the operator from such elements.

Position the winch so the operator can stand clear of the load, and out of the path of a broken wire rope that could snap back and cause injury.

Attach the winch to a rigid and level foundation that will support the winch and its load under all load conditions, including shock loading.

- 1.1.1 CONSULT APPLICABLE CODES AND REGULATIONS for specific rules on installing the equipment.
- 1.1.2 LOCATE THE WINCH in an area clear of traffic and obstacles. Make sure winch is accessible for maintenance and operation.
- 1.1.3 POSITION THE WINCH HORIZONTALLY to insure proper lubrication. **Do not install the winch vertically or up side-down, unless it has been modified for this type of installation.** To convert the winch for vertical installation, remove the four bolts holding the gearcase to the frame, turn the frame 90°, and re install the bolts. See Figure 1.
- 1.1.4 MAINTAIN A FLEET ANGLE between 1/2 and 1-1/2 degrees. The proper fleet angle minimizes wire rope damage by helping the wire rope wind uniformly onto the drum. See Figure 2.
- 1.1.5 POSITION THE WINCH to allow access for proper lubrication.
- 1.1.6 FASTEN THE WINCH securely to the foundation.
 - a FOR STANDARD PRODUCTS referred to in this manual, use 3/8 inch coarse thread fasteners, grade 5 or better, torqued dry to 30 ft-lbs without lubrication for Models 462 and 4622PB. Use 1/2 inch coarse thread fasteners, grade 5 or better, torqued dry to 75 ft-lbs without lubrication for Models 472, 4722PB, 482 and 482B. Make sure the winch frame is secured to a solid foundation able to support the winch and the load under all conditions with design factors based on accepted engineering practices.
 - b NON-STANDARD PRODUCTS that vary from the original design may have different fastening requirements. Contact a structural engineer or Thern, Inc. for this information.

TO COMPLY WITH LOCAL CODES, CONTACT A QUALIFIED PROFESSIONAL TO OBTAIN PROPER STRUCTURE OR FOUNDATION SPECIFICATIONS FOR THE MOUNTING OF THERN PRODUCTS.

1.2 Installing the Breather Plug

⚠ CAUTION

Check if a breather plug is installed to vent heat and pressure from the gear-box. Failure to do so could result in pressure buildup which can cause the gearbox to leak or damage the equipment. Breather plugs are required for the PB series. Refer to the parts list for your model.

This winch is shipped sealed with a plug and without lubricant in the gearbox.

- 1.2.1 INSTALL THE BREATHER PLUG in the proper location. Make s sure the breather plug is above the lubricant level. See Figure 1.
- 1.2.2 CHECK LUBRICANT LEVEL in the gearbox before operating. Refer to Section 3.2 Lubricating the Winch.

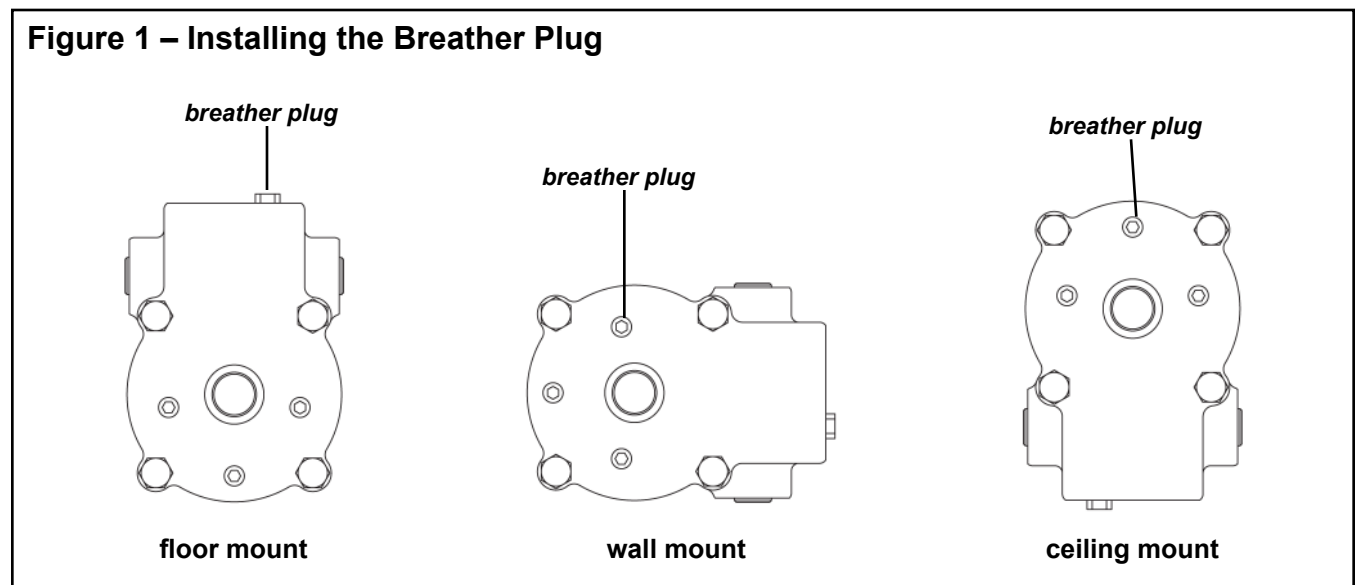

Important!

- Use a sheave or roller guide to direct the wire rope to the drum whenever possible.
- Install sheaves, tracks and other equipment so they will remain fixed under all load conditions. Follow the recommendations of the equipment manufacturer.
- Use sheaves of proper diameter to minimize wear on the wire rope. Follow the recommendations of the sheave manufacturer.

Figure 2 – Maintaining the Fleet Angle

When wire rope travels over a sheave or through a roller guide – maintain fleet angle by locating the sheave or guide an appropriate distance from the drum, shown as distance “A”.

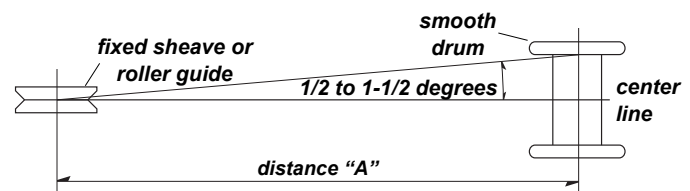

When wire rope travels directly to the load – maintain fleet angle by controlling side-to-side movement of the load with tracks or guide rails. Allowing the load to move too far to one side causes stress on the drum flange which may cause damage.

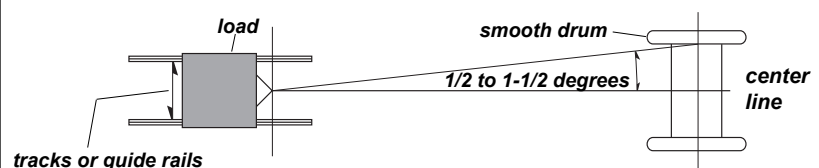

1.3 Installing the Handle

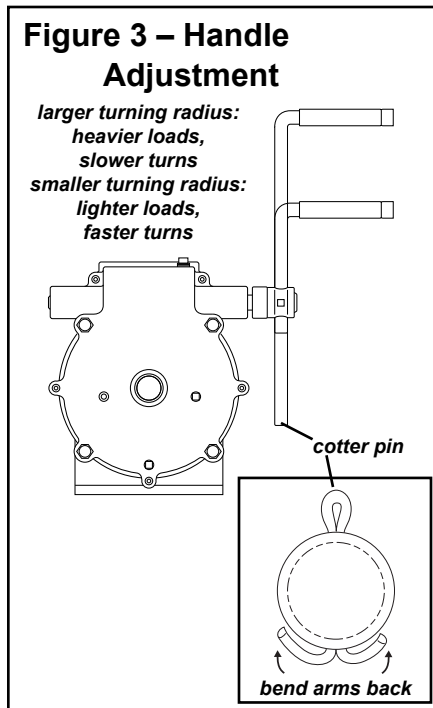

- 1.3.1 FOR MODELS 462, 472, 482 AND 482B, install the handle as follows, see Figure 3.
 - a INSERT THE HANDLE in the handle socket, adjust handle length to suit the operation, and tighten the set screw to hold it in place.
 - b INSERT THE COTTER PIN in the end of the handle and bend the arms back to secure in place.
- 1.3.2 FOR MODELS 4622PB AND 4722PB equipped with PB brakes, install the handle as follows:
 - a LOOSEN THE THUMBSCREW and slide the handle toward the medallion as shown. See Figure 4A.
 - b LINE UP THE NOTCH in the handle with the point of the hex in the medallion. See Figure 4B.
 - c SLIDE THE HANDLE AND MEDALLION ASSEMBLY onto the hex drive on the brake until the flat of the handle lines up with the groove in the hex drive. See Figure 4C.
 - d SLIDE THE HANDLE outward away from the medallion to the desired length and tighten the thumbscrew. See Figure 3B.

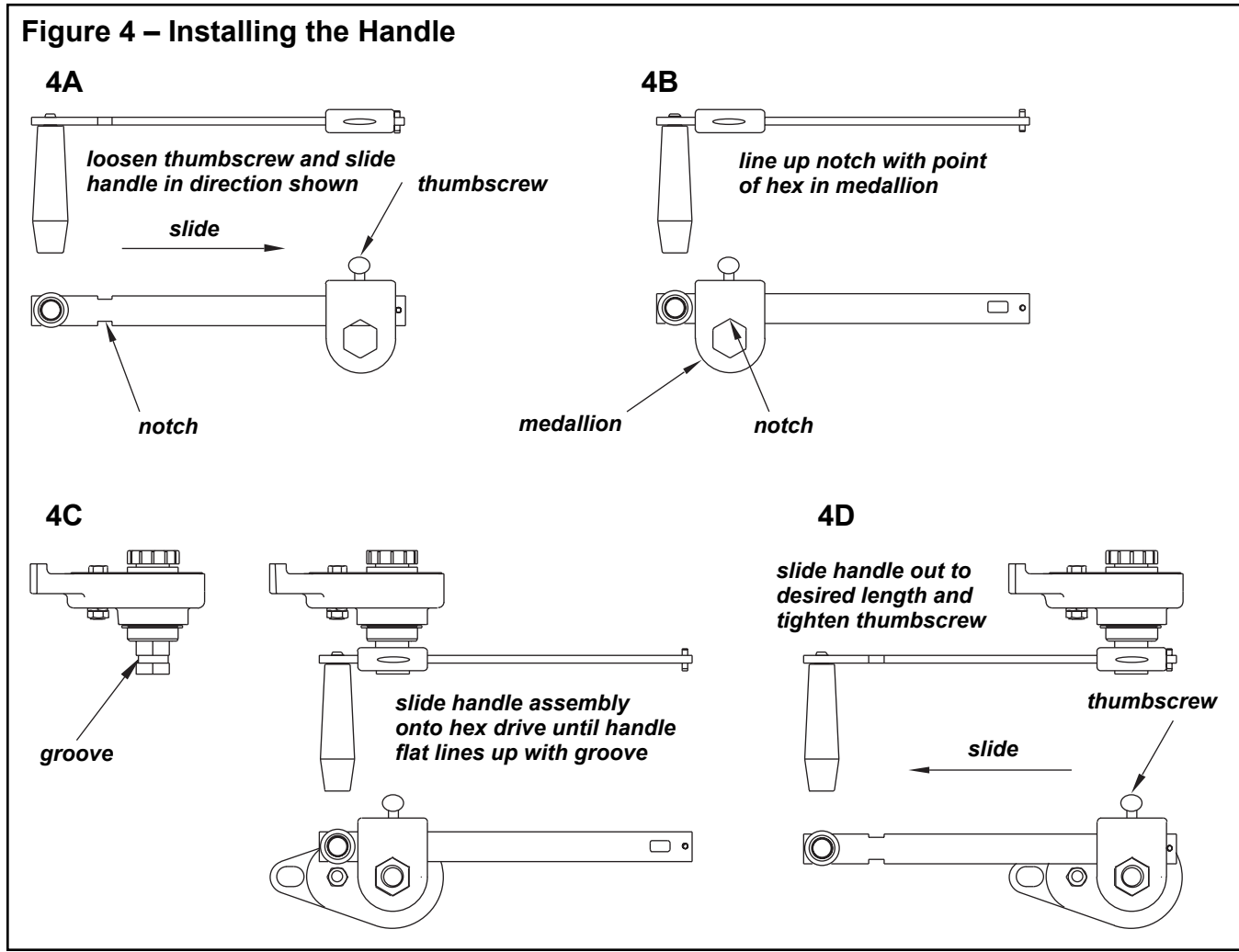

1.4 Installing the Wire Rope

Important!

- Use wire rope and other rigging equipment rated for the size of the largest load you will be moving.
- Do not drag the wire rope through dirt or debris that could cause damage, or poor operation.
- Always wear protective clothing when handling wire rope.

⚠WARNING

Install the wire rope securely to the winch drum. A poorly secured wire rope could come loose from its anchor and allow the load to escape.

Install the wire rope so it is wound correctly as shown or the winch and brake will not work properly, and could allow the load the escape, see Figures 5 and 6.

- 1.4.1 PURCHASE THE PROPER WIRE ROPE for your application. Keep the following in mind when selecting a wire rope. Contact a reputable wire rope supplier for help.
- BREAKING STRENGTH of new wire rope should be at least 3 times greater than the largest load placed on the winch. If loads are lifted or pulled on an incline, the breaking strength must be at least 5 times greater than the largest load. These are minimum values and will vary with the type of load and how you are moving it.
 - WIRE ROPE LAY must agree with the winding direction of the drum to help insure proper winding.
 - WE RECOMMEND 7 x 19 galvanized aircraft cable for diameters up to 5/16 inch, and 6 x 37 IWRC improved plow steel wire rope for diameters of 3/8 inch and up.
- 1.4.2 FOR MODELS 462 AND 4622PB anchor the wire rope using the cable anchor. See Figure 5.
- LOOSEN THE ANCHOR BOLT and place the wire rope between the drum flange and the bolt.
 - WRAP THE WIRE ROPE around the drum one time, and insert it between the anchor bolt and the drum, with at least 1/2 inch of rope extending beyond the anchor bolt.
 - TIGHTEN THE ANCHOR BOLT firmly until it flattens the wire rope against the drum.

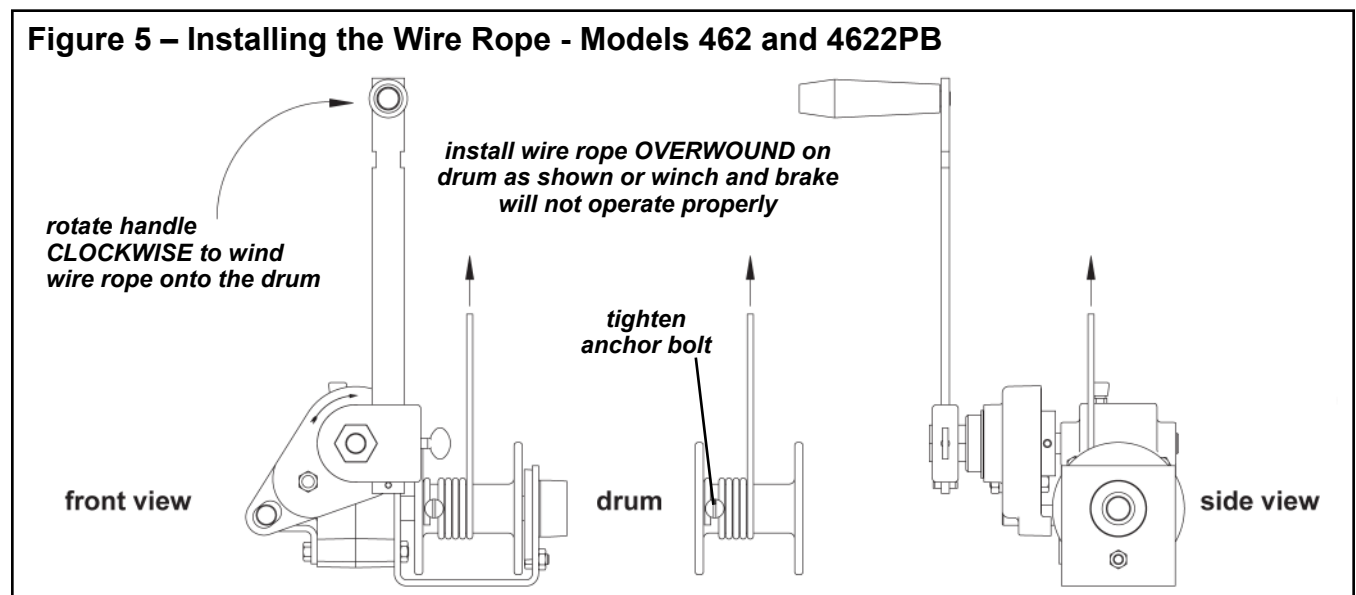

- 1.4.3 FOR MODELS 472, 4722PB, 482 AND 482B anchor the wire rope using the recessed anchor. See Figure 6.
- a PASS THE END OF THE WIRE ROPE through the anchor hole, until at least 1/2 inch of rope extends out the other side.
 - b TIGHTEN THE SET SCREW until it flattens the wire rope against the anchor hole. Use enough force to drive the point of the set screw securely into the wire rope.
- 1.4.4 TURN THE HANDLE CLOCKWISE to wind wire rope onto the drum. If wire rope unwinds from the drum when the handle is rotated clockwise, the wire rope is installed incorrectly. **Install the wire rope correctly before continuing.** See Figure 5 and 6.
- 1.4.5 WIND FOUR FULL WRAPS of wire rope onto the drum by operating the winch while holding the wire rope taught. **These wraps serve as anchor wraps and must remain on the drum at all times.**

Figure 6 – Installing the Wire Rope - Models 472, 4722PB, 482 and 48B

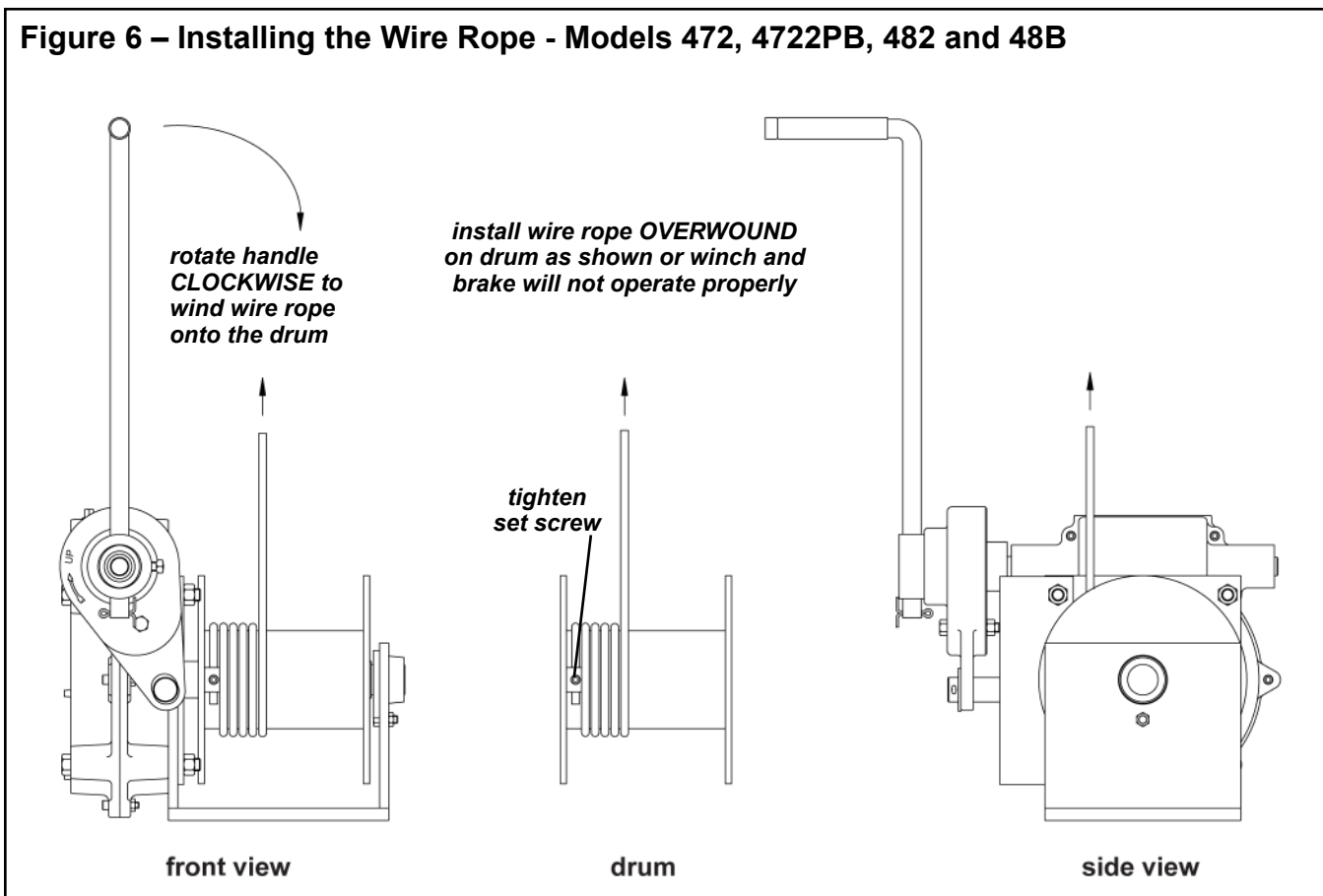

2.1 General Theory of Operation

Important!

- Limit nonuniform winding by keeping tension on the wire rope and by maintaining the proper fleet angle.
- It is your responsibility to detect and account for different factors affecting the condition and performance of the equipment.

- 2.1.1 THE PULL REQUIRED to move the load must not exceed the load rating of the winch. Consider the total force required to move the load, not the weight of the load.
- 2.1.2 THIS EQUIPMENT CAN develop forces that will exceed the load rating. It is the responsibility of the equipment user to limit the size of the load. Inspect the equipment regularly for damage according to the instructions contained in this manual.
- 2.1.3 USE A DISC BRAKE on all hand winches used to lift loads or pull loads on an incline. Although a new winch may appear to hold the load in place, this characteristic will diminish with use. **Do not depend on worm gearing to hold the load in place.**
- 2.1.4 PERFORMANCE RATINGS of the equipment are affected by the amount of wire rope wound on the drum, the way in which it is wound, and the way the winch is used.
- a DRUM CAPACITY depends on how tightly and evenly the wire rope is wound on the drum. Actual drum capacities are usually 25-30% less than values shown in performance Tables, due to loose winding and overlapping.
 - b FORCE REQUIRED TO LIFT the load increases with each additional layer of wire rope wound onto the drum.
 - c LOAD RATING represents the maximum pull that can be placed on new equipment. Load ratings are assigned values for specific amounts of load travel or wire rope accumulation. The load rating decreases as layers of wire rope accumulate on the drum.
- 2.1.5 DUTY RATINGS refer to the type of use the equipment is subject to. Consider the following when determining duty rating.
- a ENVIRONMENT: harsh environments include hot, cold, dirty, wet, corrosive, or explosive surroundings. **Protect the equipment from harsh environments when possible.**
 - b MAINTENANCE: poor maintenance, meaning poor cleaning, lubrication, or inspection, leads to poor operation and possible damage of the equipment. **Minimize poor maintenance by carefully following the instructions contained in this manual.**
 - c LOADING: severe loading includes shock loading and moving loads that exceed the load rating of the equipment. **Avoid shock loads, and do not exceed the load rating of the equipment.**
 - d FREQUENCY OF OPERATION: frequent or lengthy operations increase wear and shorten the life span of gears, bearings, and other components. **Increase maintenance of the equipment if used in frequent operations.**

CONTACT THE FACTORY FOR MORE INFORMATION.

2.2 Breaking-In the Winch

- 2.2.1 BREAK-IN OCCURS during the first 10 hours of normal operation. During break-in, mating surfaces become polished, and clearances increase. This is desired for efficient operation of bearings and gears.
- 2.2.2 INSPECT THE WINCH following break-in according to the Instructions for Periodic Inspection.

2.3 Preparing for Operation

Important!

- When determining whether the load will exceed the load rating, consider the total force required to move the load.

- 2.3.1 CONSIDER THE OPERATION. Do not begin until you are sure you can perform the entire operation without hazard.
- 2.3.2 INSPECT ALL COMPONENTS of the system.
- a INSPECT THE WINCH and other equipment according to the Instructions for Frequent Inspection.
 - b OPERATORS must be in good health, alert, thoroughly trained in operating the equipment, and properly clothed (hard hat, safety shoes and safety glasses, no loose clothing).
 - c THE LOAD must be clear of other objects and free to move. Make sure the load will not tip, spin, roll away, or in any way move uncontrollably.
- 2.3.3 KNOW YOUR LOAD and make sure you do not exceed the load rating of the winch or any other equipment in the system.

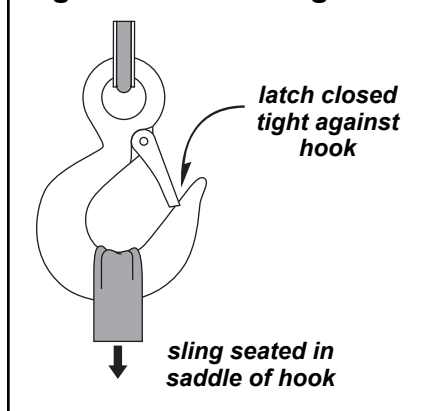
Figure 7 – Attaching Load**⚠WARNING**

Do not wrap the wire rope around the load. This damages the wire rope and could cause the load to escape. Use a sling or other approved lifting device.

- 2.4.1 CLEAR OBJECTS from the path of the load so you can move it freely and observe it at all times during the operation.
- 2.4.2 ATTACH THE LOAD using a nylon sling, or other approved lifting device. Follow the recommendations of the sling manufacturer.
- a SEAT THE SLING in the saddle of the hook with the hook latch completely closed. See Figure 7.
- b CENTER THE LOAD on the hook so it will remain balanced and not tip or rotate to one side.

Important!

- Obey a stop signal from anyone.
- Maintain tension on the wire rope to keep it tightly and evenly wound on the drum.
- If the winch and load are not visible during the entire operation, get help from another person.
- Appoint a supervisor if more than one person is involved in the operation. This will reduce confusion and increase safety.
- When lifting a load, use a tag line to keep the load from swinging or twisting, while keeping yourself away from the load.
- Remove the winch handle when the winch is not in use, to help avoid unauthorized use.

2.5 Moving the Load

- 2.5.1 MOVE THE LOAD slowly and smoothly, only a small distance at first. Make sure the load is balanced and securely attached before continuing.
- 2.5.2 TURN THE HANDLE CLOCKWISE to wind wire rope onto the drum. If wire rope unwinds from the drum when the handle is rotated clockwise, the wire rope is installed incorrectly. **Install the wire rope correctly before continuing. See Figures 5 and 6.**
- 2.5.3 GRIP THE HANDLE TIGHTLY at all times during operation. If you release the handle the load may backdrive causing the handle to spin. **Do not try to stop a spinning handle, step clear until spinning stops.**
- 2.5.4 OBSERVE THE WIRE ROPE as it winds onto the drum. If it becomes loose, uneven, or overlapped, stop the operation and rewind the wire rope before continuing. **Continued operation with overlapped or uneven wire rope can damage the wire rope and shorten its life.**
- 2.5.5 OBSERVE THE GEARBOX during operation for signs of overheating. **Frequent overheating may be a sign of damage, or may indicate the need for a larger winch.**
- a WATCH FOR SMOKE, the smell of burnt lubricant, and other signs of overheating. Use a thermocouple or other device to monitor gearbox temperature.
- b STOP THE OPERATION if the gearbox overheats, and allow the winch to cool. **Continued operation may cause damage.**

3.1 Cleaning the Winch

Important!

Increase the frequency of maintenance procedures if the winch is:

- Operated for long periods.
- Used to pull heavy loads.
- Operated in wet, dirty, hot, or cold surroundings.

Clean the winch to remove dirt and help prevent rust and corrosion.

- 3.1.1 CLEAN THE WINCH every six months or whenever it is dirty.
 - a WIPE ALL EQUIPMENT to remove dirt and grease.
 - b LEAVE A LIGHT FILM of oil on all surfaces to protect them against rust and corrosion.
 - c WIPE OFF excessive amounts of oil to avoid the accumulation of dirt.
- 3.1.2 REMOVE ALL UNNECESSARY OBJECTS from the area surrounding the winch.

Figure 8 – Lubricating the Outboard Bearing and Brake

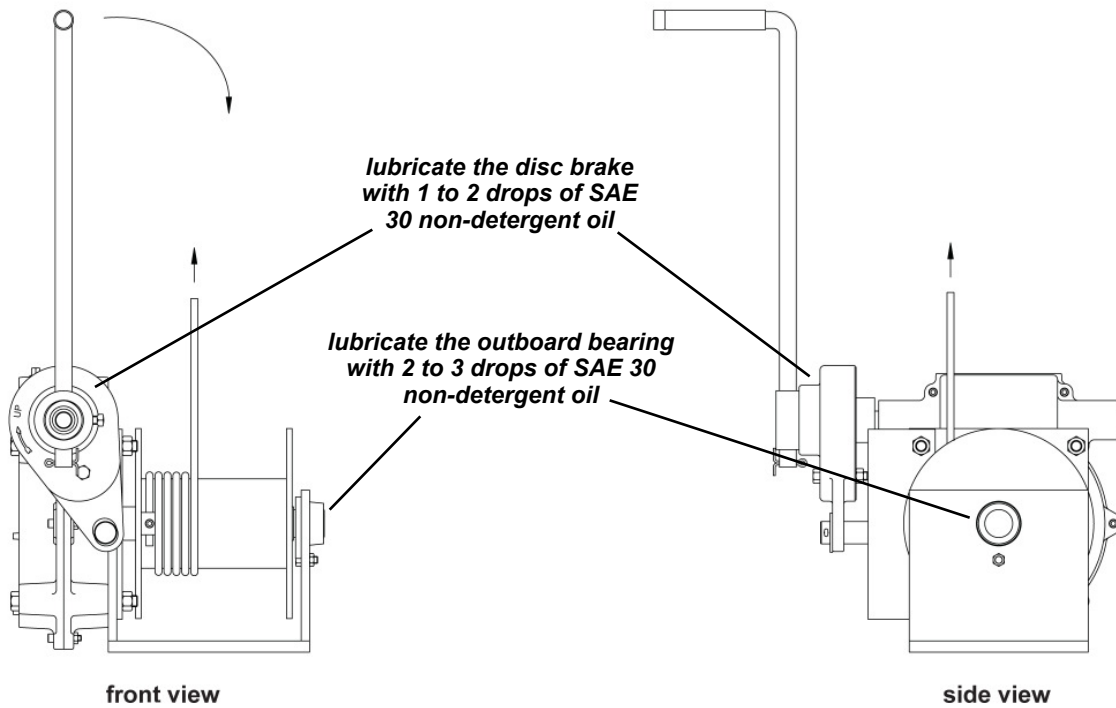
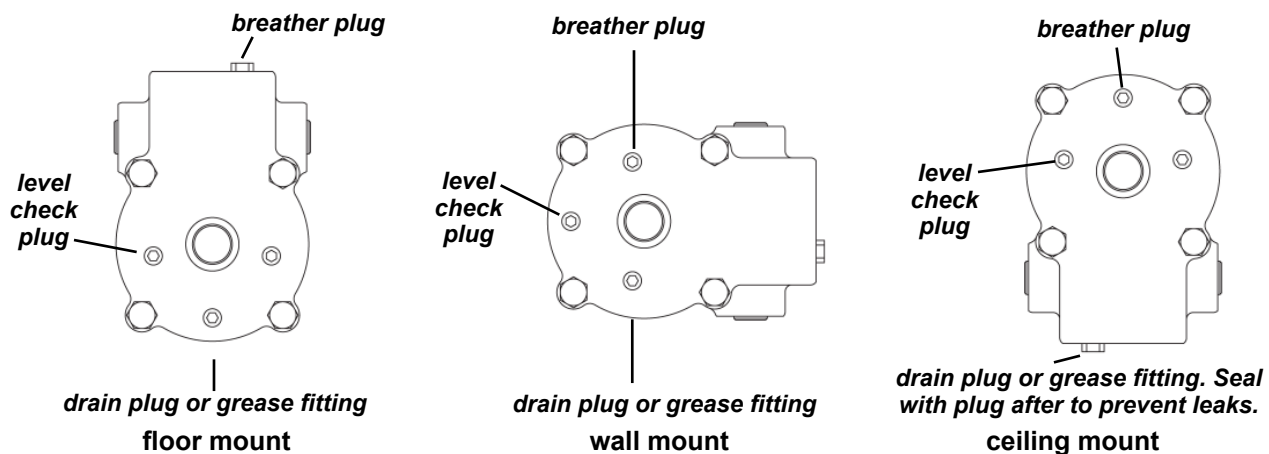

Figure 9 – Installing the Breather Plug



3.2 Lubricating the Winch

Important!

- Do not leave plug holes in the gearbox open. Open plug holes will allow dirt and moisture to contaminate the lubrication.
- Make sure lubricant has a temperature rating appropriate for the ambient temperatures of the operation.
- Use grease rated for worm gearing operation. Grease will separate and liquefy with heat or non-use over periods of time.

⚠ CAUTION

Do not over lubricate the brake bushings. Over lubricating may cause oil to leak onto the friction discs, which may damage the friction discs or result in poor operation of the disc brake.

Make sure the breather plug is clean and open to vent heat and pressure. Poor ventilation may cause overheating and result in equipment damage. Breather plugs are required for the PB series. refer to parts list for your model.

Fill the gearbox to the proper level without overfilling. Too much or too little lubricant will cause overheating and result in equipment damage.

The winch is shipped without lubricant in the gearbox. Lubricate the winch properly to help protect it from wear and rust. Read the following instructions carefully.

- 3.2.1 CHANGE GEARBOX OIL after the first 40 hours of operation.
- 3.2.2 CHECK OIL LEVEL and fill, if needed, before every operation, and every 10 hours during operation. Fill the gearbox through the breather plug hole until the lubricant reaches the level check plug. Use 90 weight gear oil. See Figure 9.
 - a CHECK OIL LEVEL by removing the check level plug. Fill the gearbox through the breather plug hole until the oil reaches the level check plug.
 - b RE-INSTALL check level plug when gearbox is filled.
- 3.2.3 CHANGE GEARBOX OIL every 6 to 12 months, or when it is dirty or otherwise contaminated. Remove the drain plug to drain oil from the gearbox. See Figure 9.
- 3.2.4 GREASE CAN BE USED as an alternate gearbox lubricant. It is not necessary to replace the grease after being placed in service.
- 3.2.5 CHECK GREASE LEVEL every 6 months of operation and fill, if needed. Fill the gearbox through the lowest plug location or drain plug hole until the lubricant reaches the level check plug. Use grease rated for worm gearing operation such as a Alco Metalube or Mobil products.
 - a CHECK GREASE LEVEL by removing the check level plug, clean plug opening and pump grease into fitting to verify grease is filled to the gear case check level plug.
 - b RE-INSTALL check level plug when gearbox is filled.
- 3.2.6 LUBRICATE THE DISC BRAKE at least every 6 months. Place 1 to 2 drops of SAE 30 non-detergent oil into the hole in the brake housing marked "oil", and turn the brake several times to allow the oil to penetrate. See Figure 8.
- 3.2.7 LUBRICATE THE WIRE ROPE and other equipment by following the manufacturer's recommendations.

3.3 Inspecting the Equipment

Important!

- Start an inspection program as soon as you put the winch into use.
- Appoint a qualified person to be responsible for regularly inspecting the equipment.
- Keep written records of inspection. This allows comparison with comments from previous inspections so you can see changes in condition or performance.

Perform frequent inspections:

- Before each operation.
- Every 3 hours during operation.
- Whenever you notice signs of damage or poor operation.

Frequent Wire Rope Inspection:

- Use ASME B30.7 as a guideline for rope inspection, replacement and maintenance.
- Check the wire rope, end connections and end fittings for corrosion, kinking, bending, crushing, bird-caging or other signs of damage.
- Check the number, distribution and type of visible broken wires. See paragraph 3.3.4 b and Figure 10.
- Check the wire rope for reduction of rope diameter from loss of core support, or wear of outside wires. See Figure 12.
- Take extra care when inspecting sections of rapid deterioration such as sections in contact with saddles, sheaves, repetitive pickup points, crossover points and end connections.

⚠WARNING

Do not use damaged or malfunctioning equipment. Place an “OUT OF ORDER” sign on the winch. Do not use the winch until the sign is removed by a qualified maintenance person who has completely corrected the problem.

Inspect the winch to detect signs of damage or poor operation before they become hazardous. See Table 1 - Inspection Checklist.

3.3.1 CONSULT APPLICABLE CODES AND REGULATIONS for specific rules on inspecting the winch and other equipment.

3.3.2 CONSULT MANUFACTURER'S RECOMMENDATIONS for information on inspecting the wire rope and other equipment.

3.3.3 Instructions for Frequent Inspection

- a VISUALLY INSPECT the entire winch and all other equipment involved in the operation.
 - Check all equipment for cracks, dents, bending, rust, wear, corrosion and other damage.
 - Make sure the wire rope is installed correctly and anchored securely to the drum.
 - Make sure the winch and brake are properly lubricated.
 - Check the gearbox for signs of leakage and make sure it is filled with the proper lubricant.
 - Make sure the breather plug is clean, open and installed properly. See Figure 1
 - Make sure fastener holding the handle in place is tight. See Figure 3 or 4.
 - Make sure mounting fasteners are tightened securely.
 - Make sure the foundation is in good condition, and capable of supporting the winch and its load under all load conditions.
- b TEST WINCH PERFORMANCE by moving a load equal to the load rating.
 - Listen for unusual noises, and look for signs of damage as you operate the winch.
 - Make sure the wire rope winds evenly and tightly onto the drum. If it is loose or uneven, rewind it before continuing.
 - Make sure the handle rotates freely in both directions.
 - Make sure the load moves smoothly without hesitation or strain.
 - On models equipped with a brake, make sure the disc brake ratchet pawl clicks firmly as the brake handle is turned clockwise.
 - On models equipped with a brake, check the brake. Raise the load, then lower it and stop it a few feet off the ground. If the load continues to coast or creep under normal operating conditions, the friction discs may be worn and in need of replacement. Contact the factory.

Completely correct all problems before continuing. Use the Troubleshooting Chart to help determine the cause of certain problems. See Table 2.

Perform periodic inspections:

- Every 6 months.
- Whenever you return the winch to service from storage.
- Whenever you notice damage or poor operation in a frequent inspection.
- Whenever you have, or think you may have, overloaded or shock loaded the winch.

Figure 10 – Broken Wires

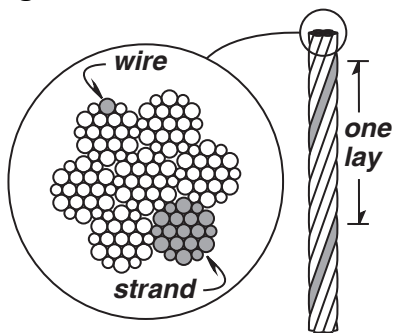

Wire rope assembly must be replaced if more than 6 wires are broken in one lay, or if more than 3 wires are broken in one strand in one lay.

Figure 11 – Load Hook Inspection

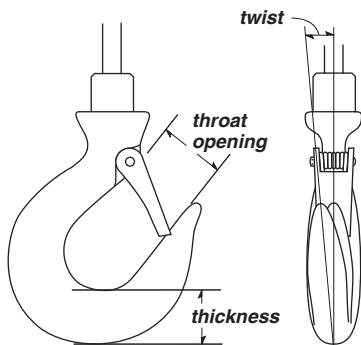

The wire rope assembly must be replaced if the throat opening is 15% wider than nominal, if the thickness is 10% less than nominal, or if the hook is twisted 10° or more.

3.3.4 **Instructions for Periodic Inspection, see Table 1.**

- VISUALLY INSPECT** the winch and all other equipment.
 - Disassembly may be required in order to properly inspect individual components. Contact factory for assembly/disassembly instructions. Disassembly of the winch or brake before contacting Thern, Inc. voids all warranties.
 - Check the finish for wear, flaking, or other damage.
 - Check all equipment, including wire rope for cracks, dents, bending, rust, wear, corrosion and other damage. If the winch was overloaded, or if you notice cracks and other signs of overloading and damage promptly remove equipment from use and have it repaired or replaced. **DO NOT CONTINUE TO USE DAMAGED OR OVERLOADED EQUIPMENT OR WIRE ROPE.**
 - Check all fasteners for stripped threads, wear, bending, and other damage.
 - Check the foundation for cracks, corrosion, and other damage.
 - Check the gearbox for signs of leakage.
 - Make sure the breather is clean, open and installed correctly.
 - Make sure all labels and plates are readable, firmly attached, free of damage and clean. Replacements are available from the factory.
- DRAIN A SMALL AMOUNT OF OIL** from the gearbox into a clean container.
 - Check the oil for dirt, metal particles, water, and other signs of contamination. Completely drain the gearbox if oil is contaminated.
 - Make sure the gearbox is properly lubricated. See 3.2 Lubricating the Winch.
- INSPECT THE WIRE ROPE** according to the wire rope manufacturer's recommendations, or follow accepted industry standards for wire rope inspection.
 - Always wear protective clothing when handling wire rope.
 - Check the entire length of wire rope for bent wires, crushed areas, broken or cut wires, corrosion, and other damage. Carefully inspect areas that pass over sheaves or through roller guides.
 - Note the location and concentration of broken wires. Replace wire rope if more than 6 wires are broken in one lay, or more than 3 wires are broken in one strand in one lay. See Figure 10.
 - Make sure the load hook or other device is securely attached to the wire rope, and the wire rope where it is attached is not frayed, corroded, broken, or otherwise damaged.
 - Measure the throat opening, thickness, and twist of the hook. Replace the hook if it shows signs of damage. See Figure 11.
 - Make sure hook latch opens without binding and closes when released.
 - Check the anchor holes in the drum flange for signs of wear or distortion.

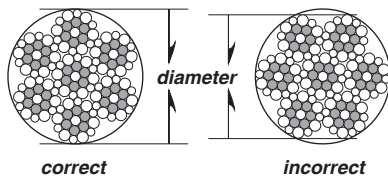
Figure 12 – Rope Diameter

The wire rope assembly must be replaced if the diameter measures less than the minimum diameter at any point.

wire rope diameter	minimum diameter
1/8 in	7/64 in (.1094 in)
3/16 in	11/64 in (.1719 in)
1/4 in	15/64 in (.2344 in)
5/16 in	19/64 in (.2969 in)

- d MOVE THE DRUM with your hands.
- Check for excessive movement indicating worn or loose gears, bearings, or shafts. Slight end play in the drive shaft is normal. Excessive movement is caused by overloading or overheating, and it is a sign that your application may require a larger winch.
 - Contact factory for assembly/disassembly instructions. Disassembly of the gearbox before contacting Thern, Inc. voids all warranties.
- e PLACE enough weight to keep the wire rope straight and tightly drawn.
- Measure the diameter of the wire rope, especially in areas where wear is noticeable. Replace the wire rope if the diameter measures below the minimum diameter at any point. See Figure 12.
- f INSPECT THE FOUNDATION AND RIGGING
- Check mounting fasteners for stripped threads, wear, and other damage.
 - Check the foundation for cracks, corrosion, and other damage.
- f FASTEN THE WINCH securely to the foundation.
- g TEST WINCH PERFORMANCE by operating the winch with a load equal to the load rating.
- Listen for unusual noises, and look for signs of damage as you operate the winch.
 - Make sure the wire rope winds evenly and tightly onto the drum. If it is loose or uneven, rewind it before continuing.
 - Observe the rotating drum, look for signs of loose or misaligned bearings.
 - Make sure the handle rotates freely in both directions.
 - Make sure the load moves smoothly, without hesitation or strain.
 - On models equipped with a brake, make sure the disc brake ratchet pawl clicks firmly as the brake handle is turned clockwise.
 - On models equipped with a brake, check the brake. Raise the load, then lower it and stop it a few feet off the ground. If the load continues to coast or creep, the friction discs may be worn and in need of replacement.

Completely correct all problems before continuing. Use the troubleshooting chart to help determine the cause of certain problems. See Table 2.

Table 1 – Inspection Checklist *checked boxes indicate damage or problem in need of repair*

	damages	problems
general	<input type="checkbox"/> finish weathered, flaking, otherwise damaged <input type="checkbox"/> parts cracked, bent, rusted, worn, otherwise damaged	<input type="checkbox"/> winch jerks or hesitates during operation <input type="checkbox"/> unusual noises, other signs of malfunction
fasteners	<input type="checkbox"/> stripped threads, bent, worn, otherwise damaged	<input type="checkbox"/> loose, not tightened to proper torque
worm gearbox	<input type="checkbox"/> gears, bearings, or shafts loose, otherwise damaged <input type="checkbox"/> oil leakage	<input type="checkbox"/> not filled with proper lubricant <input type="checkbox"/> lubricant contaminated
brake assembly	<input type="checkbox"/> brake corroded, cracked, worn, otherwise damaged	<input type="checkbox"/> brake does not operate properly
drum	<input type="checkbox"/> anchor hole or bolt worn, distorted, otherwise damaged	<input type="checkbox"/> excessive movement or backlash
wire rope	<input type="checkbox"/> bent, crushed, otherwise damaged <input type="checkbox"/> broken wires, see Figure 10 replace if more than 6 wires in one lay, or 3 wires in one strand in one lay, are broken <input type="checkbox"/> diameter reduced, see Figure 12 replace if diameter is excessively worn	<input type="checkbox"/> wire rope loosely or unevenly wound number per strand = number per lay = diameter =
end connections	<input type="checkbox"/> corroded, rusted, worn, otherwise damaged	<input type="checkbox"/> not securely attached
load hook	<input type="checkbox"/> twisted, bent, worn, otherwise damaged, see Figure 11 replace if twist is 10 degrees or more replace if throat width is 15% larger than nominal replace if thickness is 10% less than nominal	<input type="checkbox"/> hook latch fails to close when released twist = throat width = thickness =
labels and plates	<input type="checkbox"/> dirty, illegible, otherwise damaged	<input type="checkbox"/> loosely attached or missing

comments: _____

authorized signature: _____ **date** _____

Table 2 – Troubleshooting Chart

Contact the factory for detailed instructions if you are required to disassemble the winch or brake for any reason. Disassembly of the winch or brake before contacting Thern, Inc. voids all warranties.

problem	cause	correction
handle turns, drum doesn't turn	<ul style="list-style-type: none"> • loose or broken spring pins • loose, stripped or broken gears or keys 	<ul style="list-style-type: none"> inspect winch and brake, repair as necessary inspect gears and repair as necessary
handle turns hard or not at all	<ul style="list-style-type: none"> • winch overheated • load too heavy • gearbox contaminated with dirt or debris • spring pins loose or broken on winch or brake • disc brake damaged or locked • gears or keys broken or locked • outboard bearing broken or seized 	<ul style="list-style-type: none"> allow to cool lighten load inspect and relubricate as necessary inspect winch and brake, repair as necessary inspect brake, repair as necessary inspect and repair as necessary inspect and repair as necessary
brake does not operate properly	<ul style="list-style-type: none"> • friction discs worn or damaged • friction discs damaged from over lubrication • disc brake ratchet pawl damaged 	<ul style="list-style-type: none"> inspect and replace as necessary inspect and replace as necessary inspect and repair as necessary
oil leakage	<ul style="list-style-type: none"> • damaged gasket cement • cracked or damaged gearbox 	<ul style="list-style-type: none"> Inspect and replace as necessary inspect and repair as necessary
excessive end play on drive shaft	<ul style="list-style-type: none"> • thrust washer or bearing worn out • excessively worn gears 	<ul style="list-style-type: none"> Inspect and replace as necessary inspect and repair as necessary
excessively worn gears or bearings (excessive backlash)	<ul style="list-style-type: none"> • load too heavy • poor lubrication of gears or bearings 	<ul style="list-style-type: none"> lighten load inspect and relubricate as necessary
overheating	<ul style="list-style-type: none"> • operated too long without rest • load too heavy • poor lubrication • vent plug clogged or damaged • outboard bearing seized up 	<ul style="list-style-type: none"> allow to cool lighten load inspect and lubricate as necessary clean or replace vent plug as needed inspect and replace as necessary
unusual noises		
high pitched squeak	<ul style="list-style-type: none"> • poor lubrication 	<ul style="list-style-type: none"> inspect and relubricate as necessary
grinding noise	<ul style="list-style-type: none"> • contaminated lubrication • dirt in brake or winch gears • broken gears or outboard bearing 	<ul style="list-style-type: none"> clean and relubricate winch inspect and clean as necessary inspect and replace as necessary
rattling noise	<ul style="list-style-type: none"> • loose bolts, set screws or other fasteners 	<ul style="list-style-type: none"> tighten all bolts and other fasteners
uneven clicking noise in brake	<ul style="list-style-type: none"> • broken gear tooth in brake 	<ul style="list-style-type: none"> inspect and repair as necessary
weak clicking noise in brake	<ul style="list-style-type: none"> • spring or ratchet pawl dirty or damaged • worn brake ratchet pawl, gear, or spring 	<ul style="list-style-type: none"> inspect and clean or repair as necessary inspect and replace as necessary
no clicking noise in brake	<ul style="list-style-type: none"> • ratchet incorrectly installed • ratchet pawl damaged or worn excessively 	<ul style="list-style-type: none"> disassemble and install correctly inspect and replace as necessary
heavy thump during operation	<ul style="list-style-type: none"> • contaminants in oil • loose setscrews or keys in gears • thrust washer or bearing defective • outboard bearing defective 	<ul style="list-style-type: none"> flush gearbox and relubricate winch inspect and repair as necessary inspect and replace as necessary inspect and replace as necessary

3.4 Repairing the Winch

Important!

- It is your responsibility to determine when to replace parts. When considering whether to continue using a part or to replace it, remember that replacing it is the best way to avoid further equipment damage.
- Replace all spring pins and retaining rings when you disassemble the winch or brake for repair or inspection.
- During reassembly, use Loctite 598 Ultra Black to create a seal between the two halves of the gearbox. Contact the factory for detailed instructions. Disassembly of the gearbox before contacting Thern, Inc. voids all warranties.
- Appoint a qualified person to be responsible for all repairs to the equipment.

- 3.4.1 GET FACTORY AUTHORIZATION for all repairs. Unauthorized repairs will void the warranty, and may lead to damage or failure of the winch.
- 3.4.2 REPLACE DAMAGED OR POORLY OPERATING PARTS with Thern repair parts.
- 3.4.3 REFINISH AREAS where the paint is worn or flaking. A good finish helps to protect against corrosion and weather damage.
 - a REMOVE THE FINISH from damaged areas, down to the bare metal.
 - b CLEAN THE AREA thoroughly.
 - c REPAINT with a high quality primer and finishing coat.
- 3.4.4 TO ORDER REPAIR PARTS, contact your local dealer. Include the following information when ordering:
 - model number
 - **serial number** (or code number)
 - part number
 - date purchased, and from whom
 - description of what happened, or what is wrong
 - your name and return address

4.1 Transporting the Winch

Important!

- Keep a record of what you ship, and when you send it.

- 4.1.1 DRAIN OIL from the gearbox.
- 4.1.2 REMOVE THE BREATHER PLUG and install a sealed oil plug to prevent the loss of lubrication during shipment.
- 4.1.3 PACK THE WINCH in an upright position for transport, using the original packaging materials, if possible.
 - a FASTEN THE WINCH to a wooden base using the lag bolts, to keep it from moving during transport.
 - b SEAL THE WINCH in plastic with a desiccant to help protect it from rust, corrosion, and other damage.
 - c CONSTRUCTION WOODEN SIDES and top to enclose the winch in a solid protective crate.
 - d PACK LOOSE PARTS in a small box or ship separately .
- 4.1.4 INSPECT THE WINCH according to Section 3.3 Inspecting the Equipment before installing it in a new location.

4.2 Storing the Winch

- 4.2.1 LUBRICATE THE WINCH as necessary, and make sure the breather plug is clean and properly installed. Add a rust preventative for long term storage.
- 4.2.2 SEAL THE WINCH in plastic with a desiccant to help protect it from rust, corrosion, and other damage.
- 4.2.3 STORE THE WINCH upright, in a cool clean place away from corrosive chemicals and moisture.
- 4.2.4 ROTATE THE DRUM periodically to keep bearing and gear surfaces from becoming lacquered.
- 4.2.5 INSPECT THE WINCH according to Section 3.3 Inspecting the Equipment before installing it in a new location.
- 4.2.6 LUBRICATE THE WINCH PROPERLY prior to operation. See Section 3.2 Lubricating the Winch.

Worm Gear Hand Winches - Configurations and Performance Characteristics³										
model ⁴ number	description	load rating (lb)			wire rope dia. (in)	drum capacity (ft) ¹			force ² gear ratio	approx. to lift 1000 lb
		1st layer	mid drum	full drum		1st layer	mid drum	full drum		
462	1000 lb – enclosed gearing (recommended for pulling only)	1000	700	500	1/8	7	61	140	15:1	34 lb
					3/16	4	28	61		
4622PB	1000 lb – enclosed gearing with brake (for lifting)	1000	700	500	1/8	7	61	140	15:1	26 lb
472	2000 lb – enclosed gearing (recommended for pulling only)	2000	1700	1300	3/16	15	65	140	24:1	24 lb
					1/4	11	35	77		
					5/16	8	23	52		
4722PB	2000 lb – enclosed gearing with brake (for lifting)	2000	1700	1300	3/16	15	65	140	24:1	24 lb
					1/4	11	35	77		
					5/16	8	23	52		
482	4000 lb – enclosed gearing (recommended for pulling only)	4000	3300	2500	1/4	23	140	300	26:1	31 lb
					5/16	18	91	200		
					3/8	14	65	140		
482B	4000 lb – enclosed gearing with brake (for lifting)	4000	3300	2500	1/4	23	140	300	26:1	31 lb
					5/16	18	91	200		
					3/8	14	65	140		

Please contact factory or nearest Thern Distributor for firm fixed price and delivery.

¹ Actual drum capacities may be 25-30% less, due to nonuniform winding. Wire rope tension will also affect drum capacity.

² Approximate handle force required to lift 1000 lb with an empty drum, and maximum handle length.

³ Performance Characteristics are for standard products referred to in this manual. Non-standard products may vary from the original design. Contact Thern, Inc. for this information.

⁴ Models ending with a V have frames rotated 90 degrees. Performance characteristics for vertical models are the same as with standard models.

Worm Gear Hand Winch		Models 462 and 462V ¹	
item	description	part number	qty.
1	GEARCASE	C1404	1
2	CAPSCREW HEXHD .312-18NC X 3.000 ZNPL GR5	A3503	4
3	NUT HEX .312-18NC ZNPL GR2	A3250	4
4	INPUT SHAFT	A1545	1
5	SHIM SET	A2690	2
6	WORM	A1544	1
7	SLOTTED SPRING PIN .187 X 1.125 STL	A4041	1
8	PIPE PLUG SQHD .125-27NPT X .35 PLN STL	A3407	3
9	SLOTTED SPRING PIN .187 X 1.250 STL	A2849	1
10	COTTER PIN .125 X .875 STL ZNPL	A4095	1
11	FRAME	B1183	1
12	PIPE PLUG HEXSOC .125-27NPT X .31 SAE	A3405	3
13	WORM GEAR	A5046	1
14	SLOTTED SPRING PIN .250 X 1.500 STL	A4499	2
15	SLOTTED SPRING PIN .156 X 1.500 STL	A4037	2
16	OUTPUT SHAFT	A1541	1
17	OUTBOARD BEARING	A1542	1
18	DRUM	A1117	1
19	MACHINE SCREW TRSHD NYLK .250-20NC X .500 ZNPL	A1122	1
20	HANDLE ASSEMBLY	B1038	1
21	SOCKET	A1457	1
22	SETSCREW SQHD .312-18NC X .500 ZNPL STL	A3724	1
23	LABEL CODE	10477	1
24	LABEL WARNING TO AVOID INJURY	A1978	1
25	LABEL THIS WINCH HAS NO AUTOMATIC BRAKE	A2692	1
26	LABEL CAUTION THIS UNIT IS NOT FACTORY	A2175	1
27	LABEL OIL W/ARROW	A2176	3
28	LABEL MODEL/CAPACITY 462	A7529	1

¹ Models ending with a V have frames rotated 90 degrees.

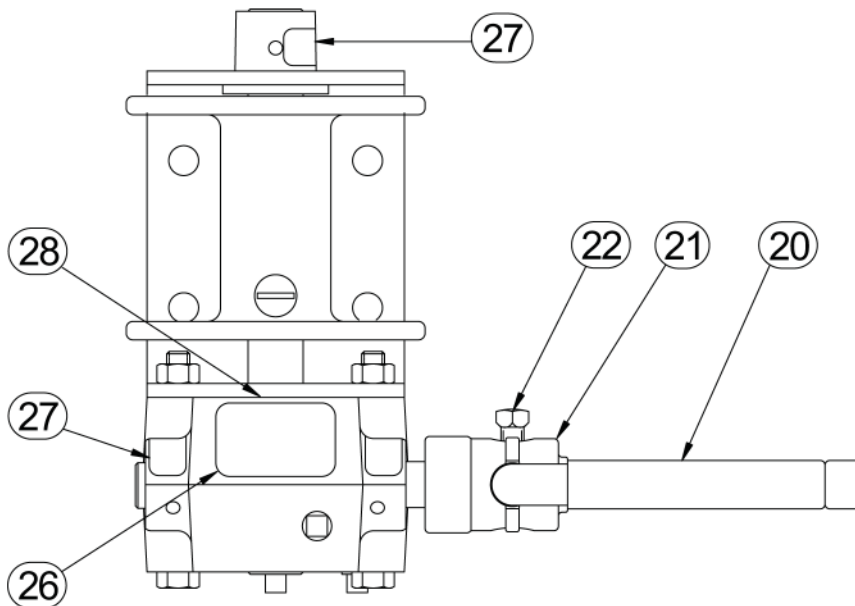

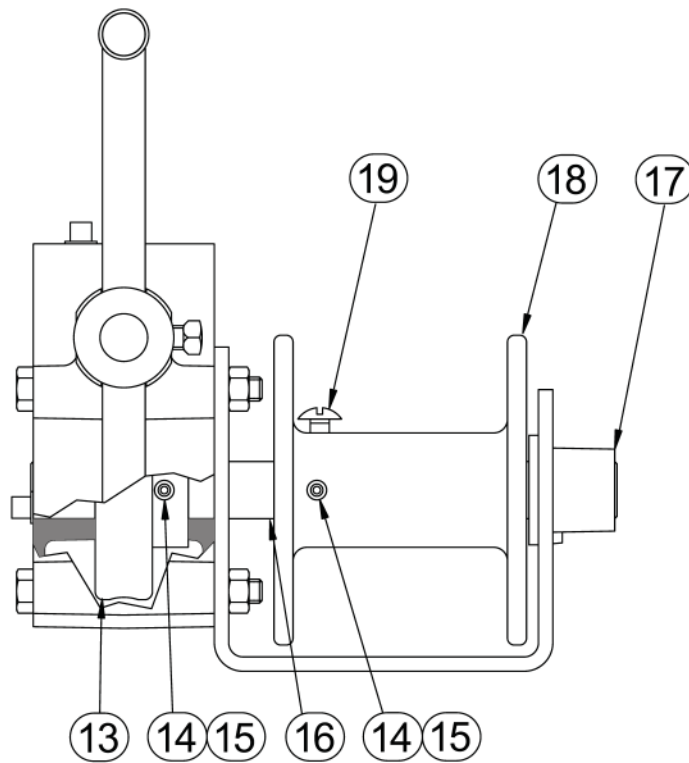
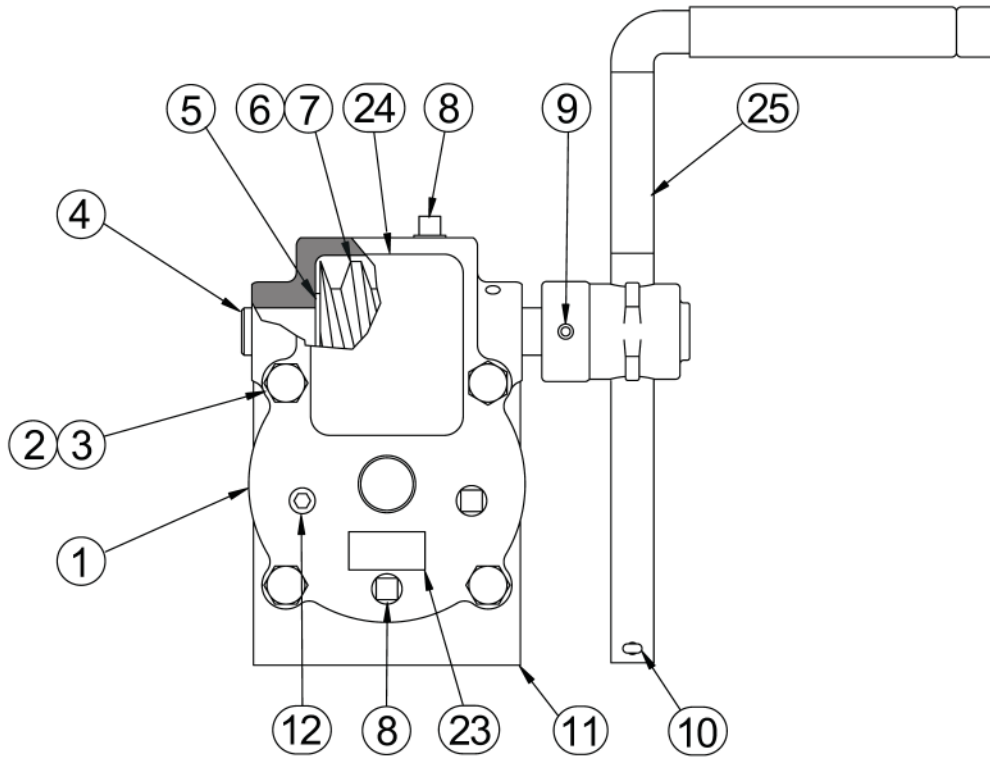

Worm Gear Hand Winch		Models 4622PB and 4622PBV ¹	
item	description	part number	qty.
1	GEARCASE	C2681	1
2	CAPSCREW HEXHD .312-18NC X 3.000 ZNPL GR5	A3503	4
3	HEX NUT .312-18NC ZNPL GR2	A3250	5
4	WASHER HELSPRLK .312 X .586 X .078 ZNPL	A2925	3
5	INPUT SHAFT	A5044	1
6	OIL SEAL .625ID X .875OD X .188	A3042	2
7	BEARING SLEEVE .625ID X .875OD X .625 BRZ	A3040	2
8	SHIM SET	A2689	2
9	WORM	A5045	1
10	SETSCREW SOKHD NYLK .250-20NC X .250 BLKOX	A3260	1
11	KEY .188 X .188 X 1.750 4140 HT BER	A4481	1
12	PIPE VENT PLUG .125-27NPT	A4442	1
13	GROOVE PIN TYPE A .187 X 2.000 ALYSTL	A4532	1
14 ²	BRAKE DISC ASSEMBLY	C3823	1
15 ³	HANDLE MEDALLION ASSEMBLY	B4218	1
16	BRAKE ARM	B1588	1
17	FRAME	B2710	1
18	PIPE PLUG HEXSOC .125-27NPT X .31 SAE	A3405	5
19	OIL SEAL .750ID X 1.000OD X .125	A4355	1
20	BEARING SLEEVE .750ID X 1.000OD X .625 BRZ	A3655	1
21	WORM GEAR	A5046	1
22	GROOVE PIN TYPE A .250 X 1.500 ALYSTL	A4456	1
23	BEARING SLEEVE .750ID X 1.000OD X .312 BRZ	A5040	1
24	OUTPUT SHAFT	A5043	1
25	SLOTTED SPRING PIN .250 X 1.500 STL	A4499	1
26	SLOTTED SPRING PIN .156 X 1.500 STL	A4037	1
27	CAPSCREW HEXHD .312-18NC X .500 ZNPL GR5	A3507	1
28	BEARING HOUSING ASSEMBLY	A6074	1
29	DRUM	A1117	1
30	MACHINE SCREW TRSHD NYLK .250-20NC X .500 ZNPL	A1122	1
31	LABEL CODE	10477	1
32	LABEL WARNING TO AVOID INJURY	A1978	1
33	LABEL CAUTION THIS UNIT IS NOT FACTORY	A2175	1
34 ⁴	LABEL MODEL/CAPACITY 4622PB	A8113	1
35	LABEL OIL W/ARROW	A2176	1

¹ Models ending with a V have frames rotated 90 degrees.
² Model 462PB-P3 uses C1455
³ Model 462PB-P3 not supplied with B4218
⁴ Model 462PB-P3 uses A7530

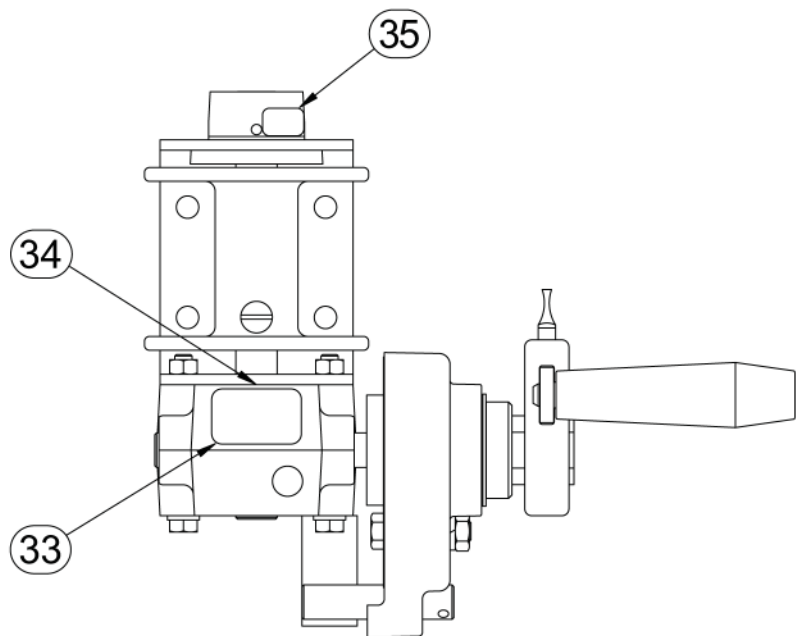

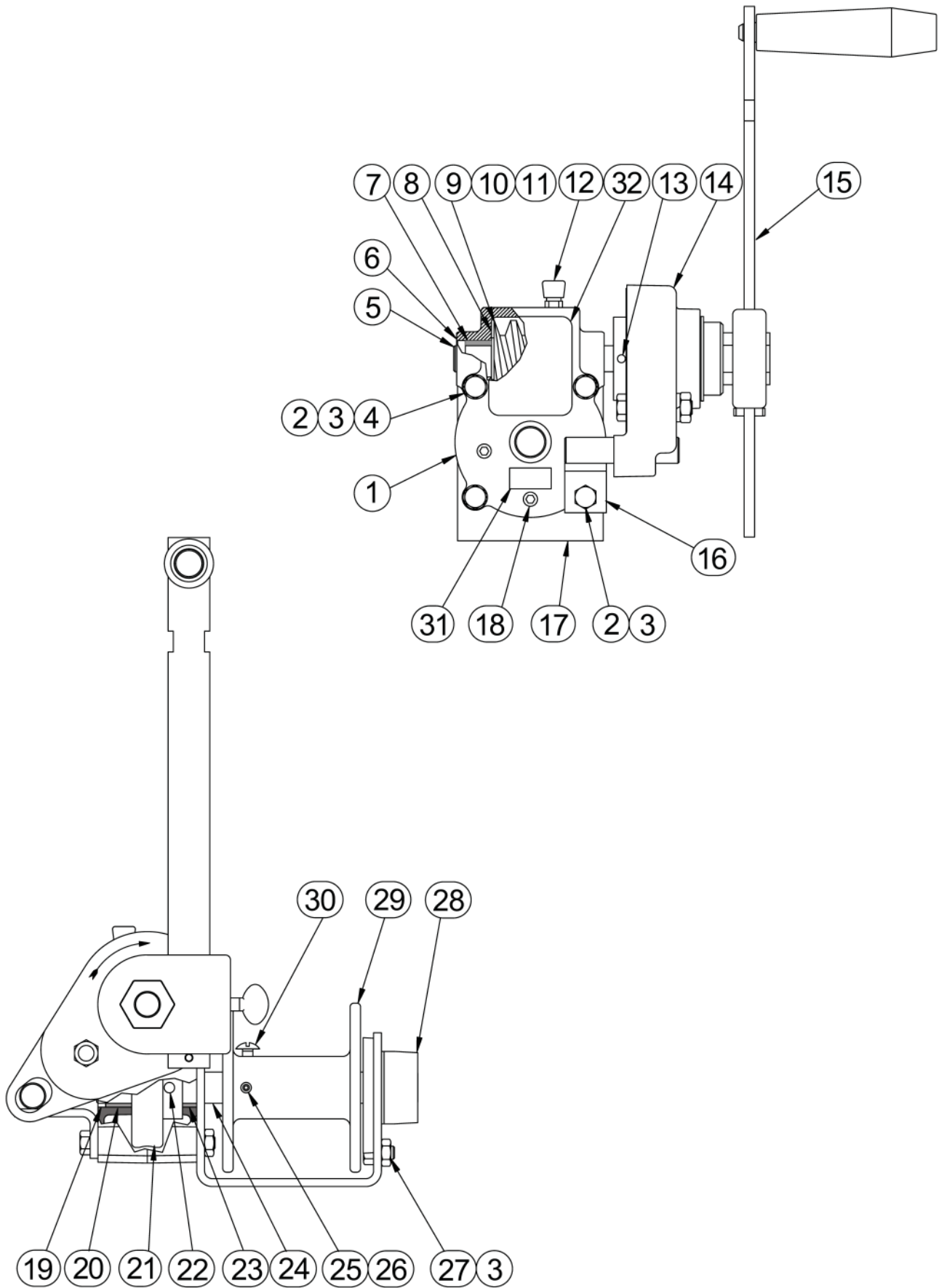

Worm Gear Hand Winch		Models 472 and 472V ¹	
item	description	part number	qty.
1	GEARCASE	C1392	1
2	CAPSCREW SOKHD .250-20NC X 1.250 ALYSTL	A3288	2
3	HEX NUT .250-20NC ZNPL GR2	A3200	2
4	CAPSCREW HEXHD .312-18NC X 3.250 ZNPL GR5	A3404	4
5	HEX NUT .312-18NC ZNPL GR2	A3250	4
6	INPUT SHAFT	A1464	1
7	WORM GEAR ASSEMBLY	B1186	1
8	WORM	A1462	1
9	SLOTTED SPRING PIN .187 X 1.125 STL	A4041	1
10	THRUST BEARING .625ID X 1.500OD X .125 BRZ	A3395	2
11	PIPE PLUG SQHD .375-18NPT X .525 BLKOX	A4126	1
12	SPACER	A2007	2
13	SHIM	A4394	2
14	SLOTTED SPRING PIN .187 X 1.250 STL	A2849	1
15	COTTER PIN .125 X .875 STL ZNPL	A4095	1
16	PIPE PLUG SQHD .125-27NPT X .35 PLN STL	A3407	2
17	PIPE PLUG HEXSOC .125-27NPT X .31 SAE	A3405	3
18	SLOTTED SPRING PIN .187 X 2.000 STL	A3398	1
19	SLOTTED SPRING PIN .312 X 2.000 STL	A3303	1
20	FRAME	C1109	1
21	CAPSCREW HEXHD .312-18NC X .750 ZNPL GR5	A3032	1
22	HEX NUT NYLK .312-18NC ZNPL GR2	A2927	1
23	OUTBOARD BEARING	A1463	1
24	DRUM	B1172	1
25	SETSCREW SOKHD NYLK .312-18NC X .500 BLKOX	A3746	1
26	SETSCREW SQHD .312-18NC X .500 ZNPL STL	A3724	1
27	SOCKET	A1457	1
28	HANDLE ASSEMBLY	B1038	1
29	LABEL CODE	10477	1
30	LABEL CAUTION THIS UNIT IS NOT FACTORY	A2175	1
31	LABEL WARNING TO AVOID INJURY	A1978	1
32	LABEL THIS WINCH HAS NO AUTOMATIC BRAKE	A2692	1
33	LABEL OIL W/ARROW	A2176	3
34	LABEL MODEL/CAPACITY 472	A7531	1

¹ Models ending with a V have frames rotated 90 degrees.

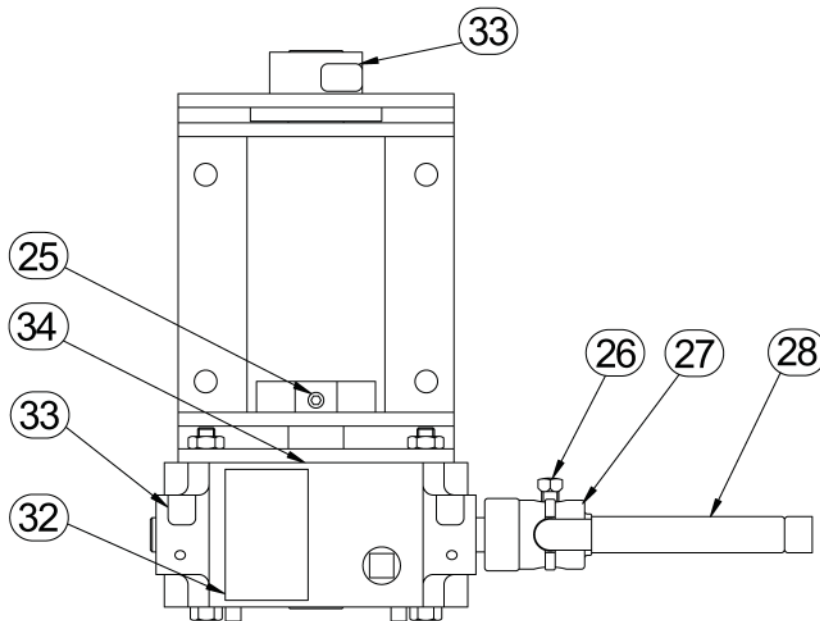

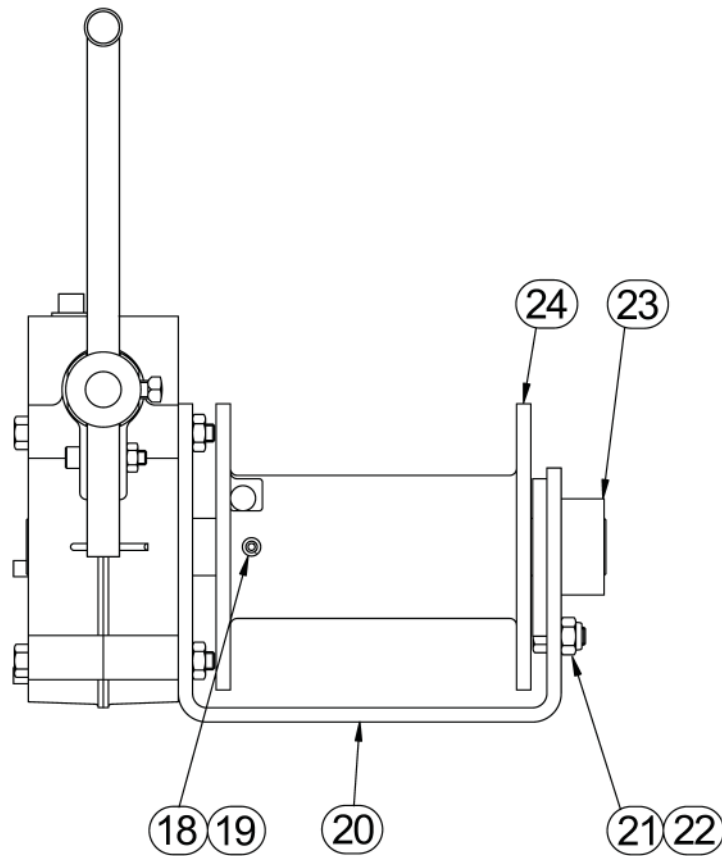
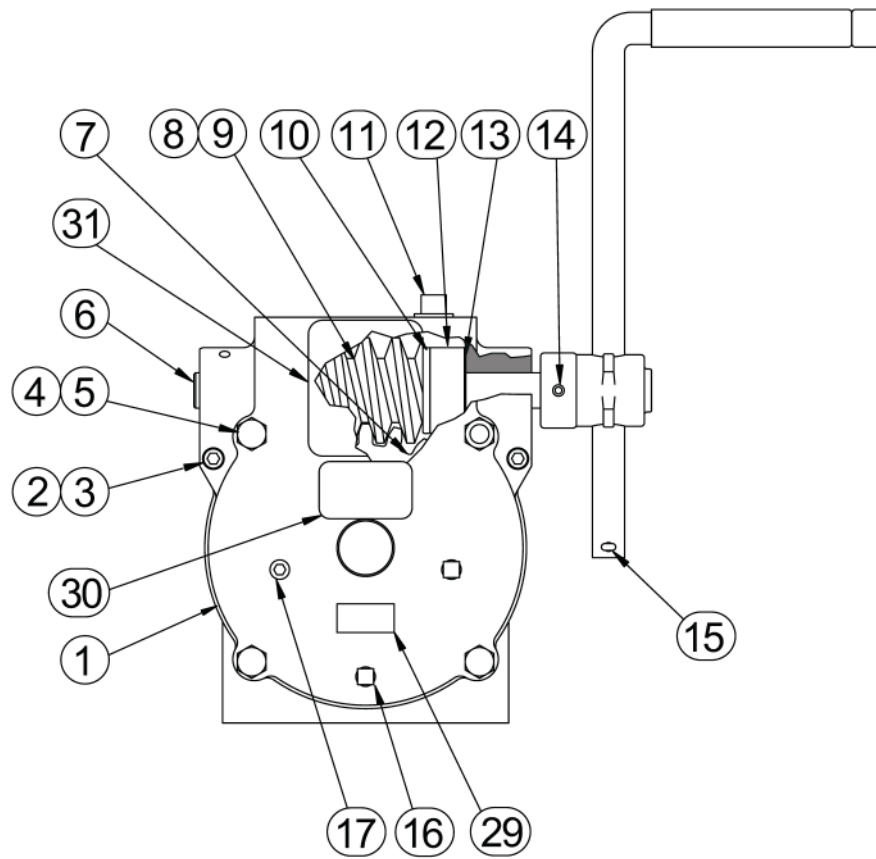

Worm Gear Hand Winch		Models 4722PB and 4722PBV ¹	
item	description	part number	qty.
1	GEARCASE	C1339	1
2	CAPSCREW SOKHD .250-20NC X 1.250 ALYSTL	A3288	2
3	HEX NUT .250-20NC ZNPL GR2	A3200	2
4	CAPSCREW HEXHD .312-18NC X 3.250 ZNPL GR5	A3404	2
5	HEX NUT .312-18NC ZNPL GR2	A3250	4
6	INPUT SHAFT	SB3748	1
7	WORM GEAR ASSEMBLY	B1186	1
8	WORM	A5015	1
9	KEY .188 X .188 X 2.000 4140 HT BER	A3255	1
10	SETSCREW SOKHD NYLK .250-20NC X .250 BLKOX	A3260	1
11	THRUST BALL BEARING .753ID X 1.685OD X .625	A1498	2
12	BREATHER PLUG .375-18NPT X .48 PLN STL	A3408	1
13	SHIM SET	A1928	2
14	BEARING SLEEVE .750ID X 1.000OD X 1.000 BRZ	A3656	2
15	OIL SEAL .750ID X 1.000OD X .125	A4355	2
16	GROOVE PIN TYPE A .187 X 2.000 ALYSTL	A4532	1
17	BRAKE DISC ASSEMBLY	C3823	1
18	HANDLE MEDALLION ASSEMBLY	B4218	1
19	BRAKE ARM	SB3746	1
20	CAPSCREW HEXHD .312-18NC X 3.500 ZNPL GR5	A3501	2
21	PIPE PLUG SQHD .125-27NPT X .35 PLN STL	A3407	2
22	PIPE PLUG HEXSOC .125-27NPT X .31 SAE	A3405	3
23	BEARING SLEEVE 1.000ID X 1.250OD X .656 BRZ	A3640	2
24	OIL SEAL 1.000ID X 1.250OD X .125	A4356	2
25	GROOVE PIN TYPE A .312 X 2.000 ALYSTL	A2557	1
26	FRAME	C1109	1
27	CAPSCREW HEXHD .312-18NC X .750 ZNPL GR5	A3032	1
28	HEX NUT NYLK .312-18NC ZNPL GR2	A2927	1
29	BEARING HOUSING ASSEMBLY	A6123	1
30	DRUM	B1172	1
31	SETSCREW SOKHD NYLK .312-18NC X .500 BLKOX	A3746	1
32	LABEL CODE	10477	1
33	LABEL WARNING TO AVOID INJURY	A1978	1
34	LABEL CAUTION THIS UNIT IS NOT FACTORY	A2175	1
35	LABEL MODEL/CAPACITY 4722PB	A8115	1
36	LABEL OIL W/ARROW	A2176	1

¹ Models ending with a V have frames rotated 90 degrees.

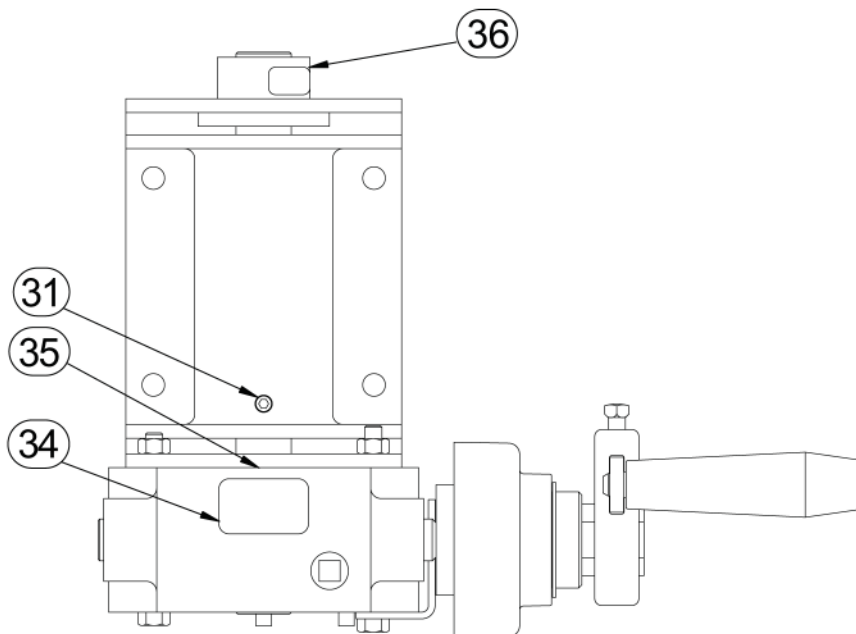

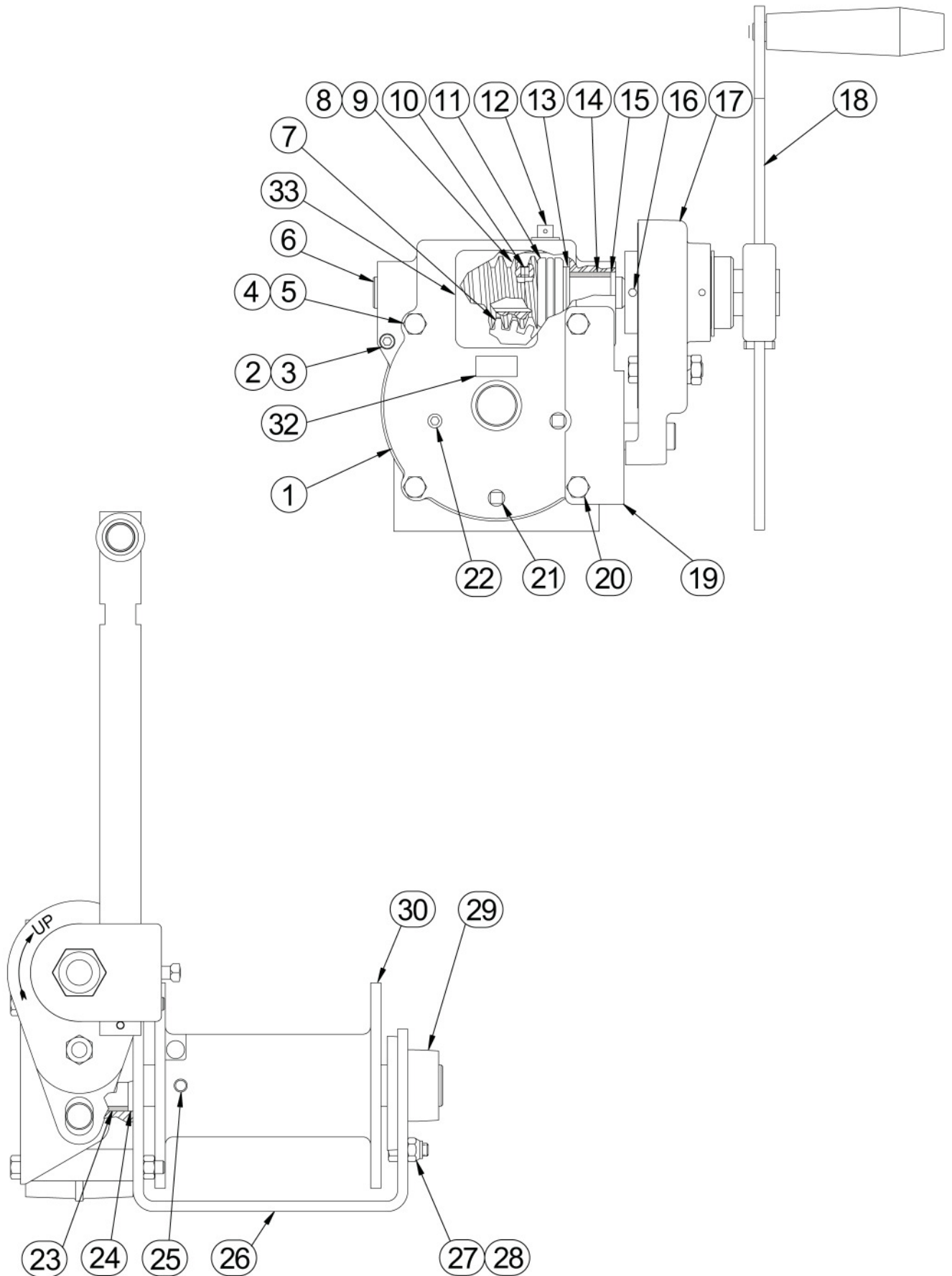

Brake Assembly for Model 4622PB and 4722PB		C3823	
item	description	part number	qty.
1	BRAKE COVER	A1105	1
2	BRAKE HOUSING/BEARING ASSEMBLY	C2678	1
3	RETAINING RING 1.750 SST	A3883	1
4 ¹	BRAKE DRIVE ASSEMBLY	B4210	1
5	CAPSCREW HEXHD .375-16NC X 1.500 SST	A3884	1
6	TORSION SPRING SST	A1842	1
7	RATCHET PAWL	A1103	1
8	HEX JAM NUT .375-16NC SST	A3330	1
9	LOCK WASHER HELSPR .375 X .683 X .094 SST	A3357	1
10	SPACER .391 X .500 X .675	A1104	1

¹ Brake Drive Assembly ordered complete.

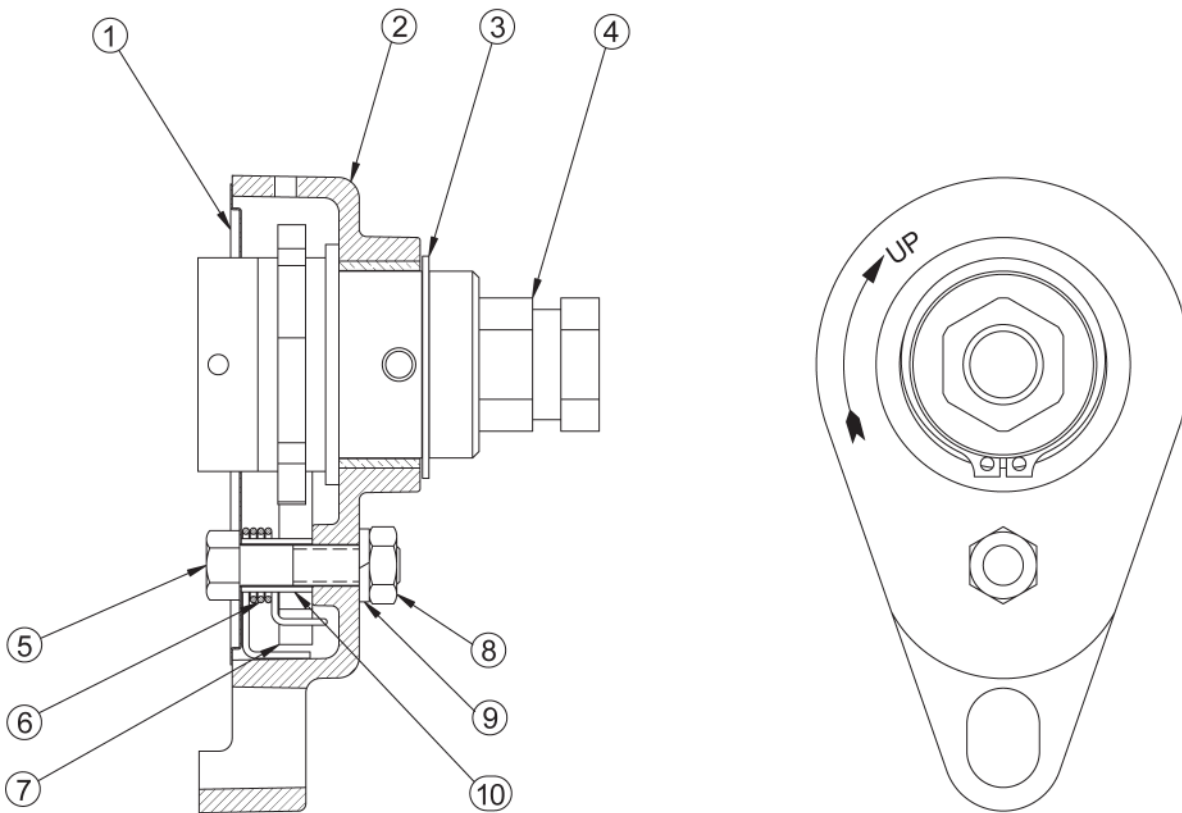

Brake Assembly for Model 462PB-P3		C1544	
item	description	part number	qty.
1	BRAKE COVER	A1105	1
2	BRAKE HOUSING/BEARING ASSEMBLY	C2678	1
3	RETAINING RING 1.750 SST	A3883	1
4 ¹	DRIVE ASSEMBLY	B2337	1
5	CAPSCREW HEXHD .375-16NC X 1.500 SST	A3884	1
6	TORSION SPRING SST	A1842	1
7	RATCHET PAWL	A1103	1
8	HEX JAM NUT .375-16NC SST	A3330	1
9	LOCK WASHER HELSPR .375 X .683 X .094 SST	A3357	1
10	SPACER .391 X .500 X .675	A1104	1

¹ Brake Drive Assembly ordered complete.

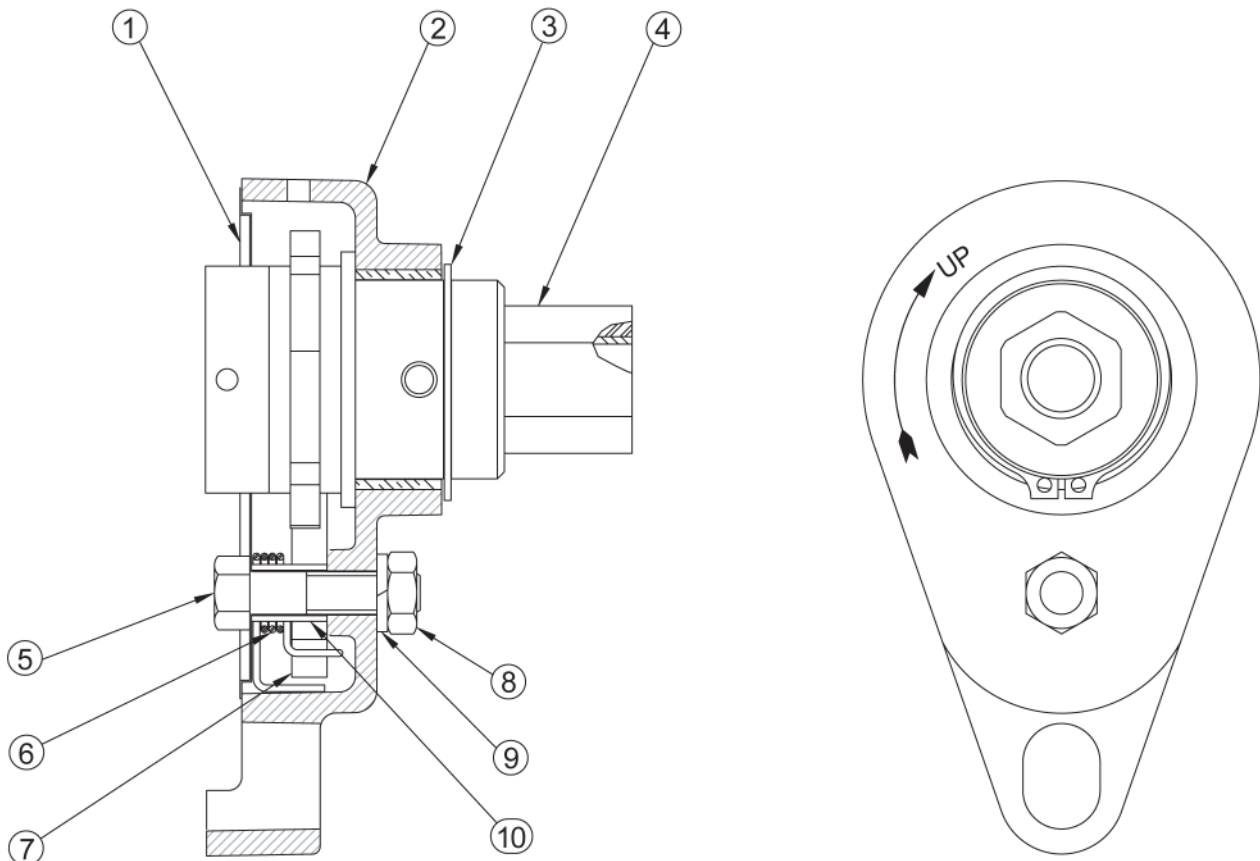

Worm Gear Hand Winch		Models 482 and 482V ¹	
item	description	part number	qty.
1	GEARCASE	C3425	1
2	CAPSCREW SOKHD .250-20NC X 1.250 ZNPL	A4568	5
3	HEX NUT .250-20NC ZNPL GR2	A3200	5
4	CAPSCREW HEXHD .500-13NC X 5.000 ZNPL GR5	A3247	4
5	HEX NUT .500-13NC ZNPL GR2	A3227	4
6	INPUT SHAFT	B1196	1
7	WORM GEAR ASSEMBLY	B1194	1
8	WORM	B1195	1
9	SETSCREW SOKHD NYLK .250-20NC X .500 BLKOX	A3742	1
10	KEY .250 X .250 X 3.500 4140 HT BER	A3438	1
11	THRUST BEARING 1.012ID X 1.75OD X .125 BRZ	A1478	2
12	SPACER	A1479	2
13	SHIM SET	A2672	2
14	COTTER PIN .187 X 1.250 ZNPL STL	A3155	1
15	SOCKET	A1480	1
16	SETSCREW SQHD .375-16NC X .500 ZNPL STL	A3725	1
17	HANDLE ASSEMBLY	B1045	1
18	PIPE PLUG SQHD .125-27NPT X .35 PLN STL	A3407	2
19	PIPE PLUG HEXSOC .125-27NPT X .31 SAE	A3405	3
20	FRAME	C1113	1
21	SLOTTED SPRING PIN .312 X 3.750 STL	A4053	1
22	SLOTTED SPRING PIN .500 X 3.750 STL	A4056	1
23	CAPSCREW HEXHD .312-18NC X .750 ZNPL GR5	A3032	1
24	HEX JAM NUT NYLK .312-18NC ZNPL GR2	A3249	1
25	OUTBOARD BEARING	A1481	1
26	DRUM	C1165	1
27	SLOTTED SPRING PIN .250 X 1.500 STL	A4499	1
28	PIPE PLUG HEXSOC .375-18NPT X .425 SAE	A3290	1
29	SETSCREW SOKHD NYLK .375-16NC X .625 BLKOX	A3128	1
30	LABEL CODE	10477	1
31	LABEL CAUTION THIS UNIT IS NOT FACTORY	A2175	1
32	LABEL WARNING TO AVOID INJURY	A1979	1
33	LABEL THIS WINCH HAS NO AUTOMATIC BRAKE	A2692	1
34	LABEL OIL W/ARROW	A2176	3
35	LABEL MODEL/CAPACITY 482	A7532	1

¹ Models ending with a V have frames rotated 90 degrees.

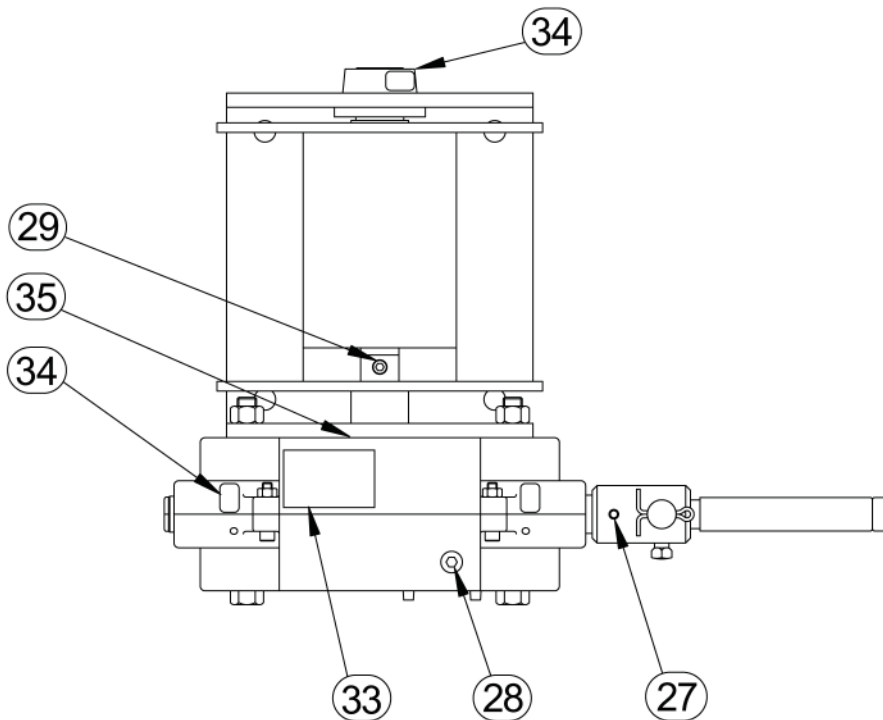

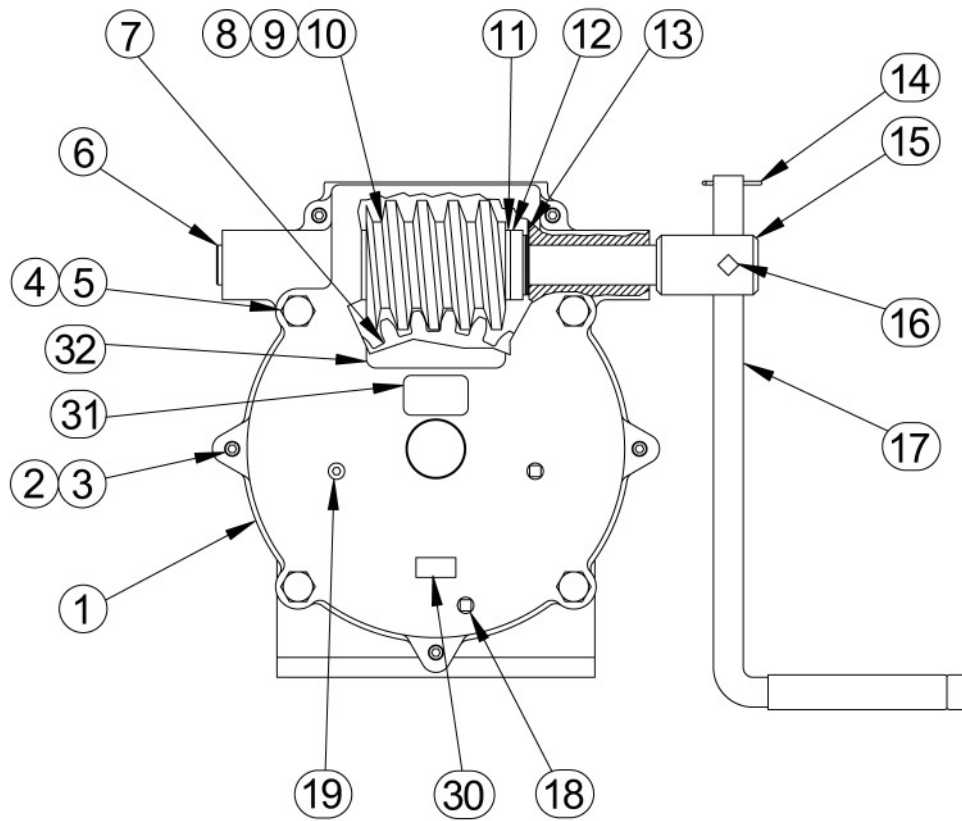
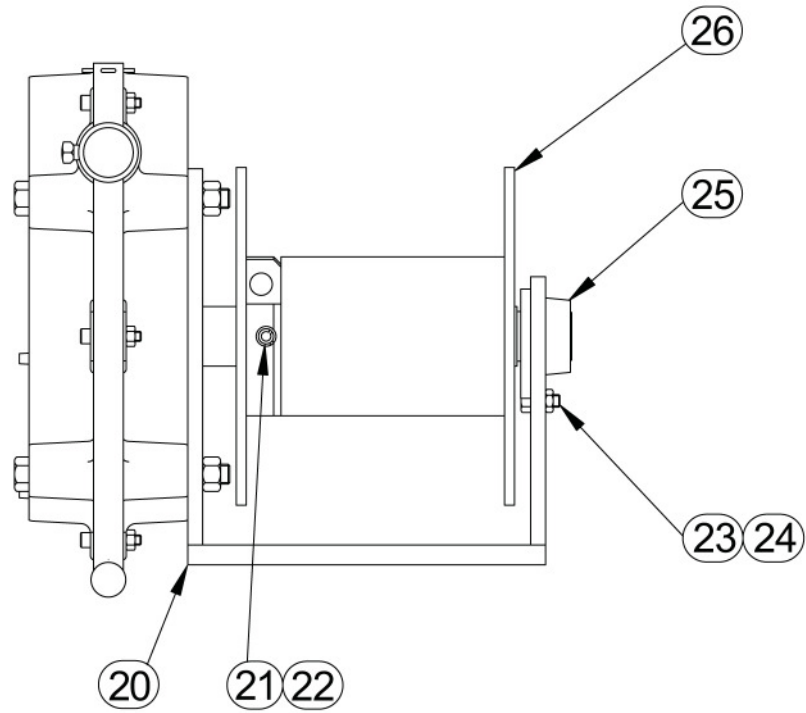

Worm Gear Hand Winch		Model 482B and 482BV ¹	
item	description	part number	qty.
1	GEARCASE	C3425	1
2	CAPSCREW SOKHD .250-20NC X 1.250 ZNPL	A4568	5
3	HEX NUT .250-20NC ZNPL GR2	A3200	5
4	CAPSCREW HEXHD .500-13NC X 5.000 ZNPL GR5	A3247	2
5	HEX NUT .500-13NC ZNPL GR2	A3227	4
6	INPUT SHAFT	B1196	1
7	WORM GEAR ASSEMBLY	B1194	1
8	WORM	B1195	1
9	SETSCREW SOKHD NYLK .250-20NC X .500 BLKOX	A3742	1
10	KEY .250 X .250 X 3.500 4140 HT BER	A3438	1
11	THRUST BEARING 1.012ID X 1.75OD X .125 BRZ	A1478	2
12	SPACER	A1479	2
13	SHIM SET	A2672	2
14	SLOTTED SPRING PIN .250 X 2.000 STL	A4048	1
15	BRAKE DISC ASSEMBLY	C3254	1
16	COTTER PIN .187 X 1.250 ZNPL STL	A3155	1
17	HANDLE ASSEMBLY	B1015	1
18	MACHINERY BUSHING 1.000 X 1.500 X 14GA ZNPL STL	A3887	1
19	COTTER PIN .187 X 1.500 STL ZNPL	A4101	1
20	BRAKE ARM	C1115	1
21	CAPSCREW HEXHD .500-13NC X 5.250 ZNPL	A7664	2
22	PIPE PLUG SQHD .125-27NPT X .35 PLN STL	A3407	2
23	PIPE PLUG HEXSOC .125-27NPT X .31 SAE	A3405	3
24	FRAME	C1113	1
25	SLOTTED SPRING PIN .312 X 3.750 STL	A4053	1
26	SLOTTED SPRING PIN .500 X 3.750 STL	A4056	1
27	CAPSCREW HEXHD .312-18NC X .750 ZNPL GR5	A3032	1
28	HEX JAM NUT NYLK .312-18NC ZNPL GR2	A3249	1
29	OUTBOARD BEARING	A1481	1
30	DRUM	C1165	1
31	PIPE PLUG HEXSOC .375-18NPT X .425 SAE	A3290	1
32	SETSCREW SOKHD NYLK .375-16NC X .625 BLKOX	A3128	1
33	LABEL CODE	10477	1
34	LABEL CAUTION THIS UNIT IS NOT FACTORY	A2175	1
35	LABEL WARNING TO AVOID INJURY	A1979	1
36	LABEL OIL W/ARROW	A2176	3
37	LABEL MODEL/CAPACITY 482B	A7665	1

¹ Models ending with a V have frames rotated 90 degrees.

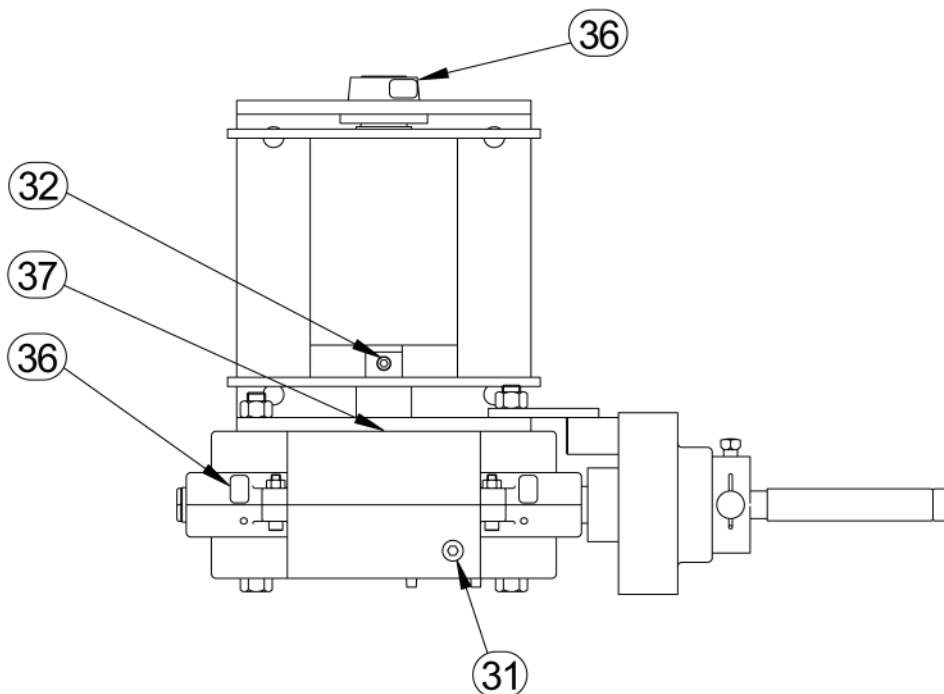

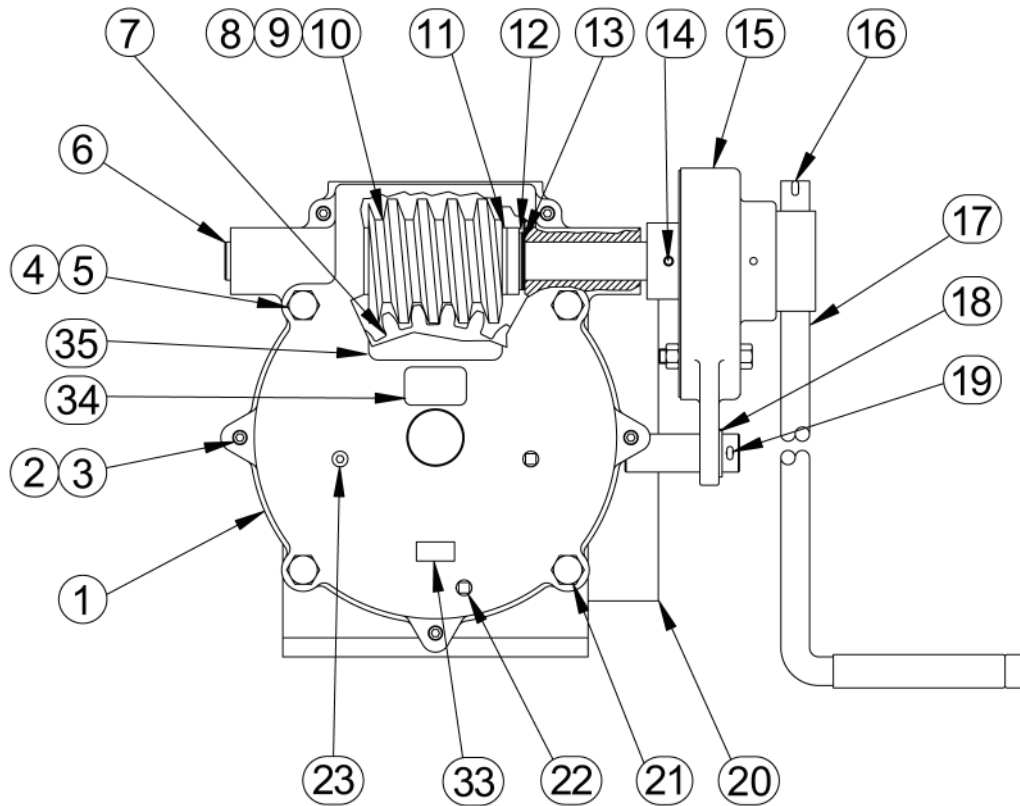
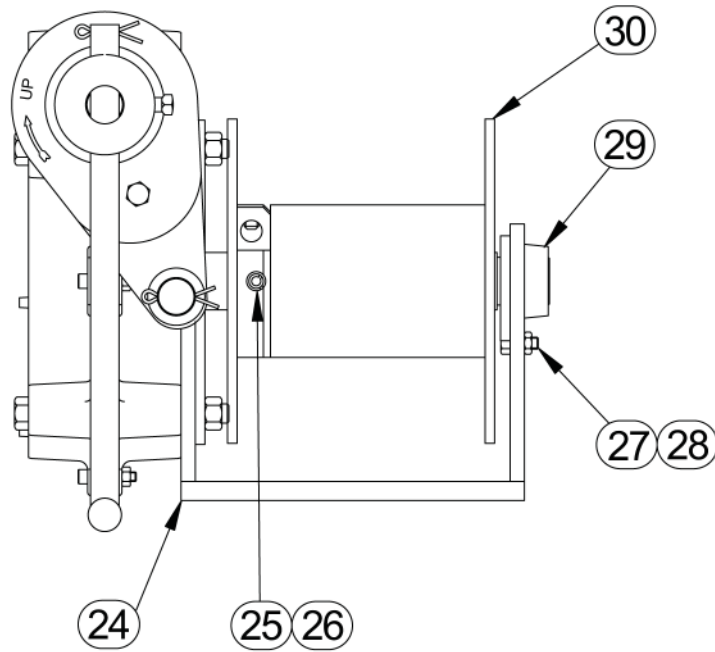



THERN

**Thern, Incorporated
5712 Industrial Park Road
Winona, MN 55987**

**PHN 507-454-2996
FAX 507-454-5282**

**EMAIL: info@thern.com
www.thern.com**